



450 EXC EU  
450 EXC Six Days EU  
450 EXC Factory Edition EU  
450 EXC AU  
450 XC-W US  
500 EXC EU  
500 EXC Six Days EU  
500 EXC AU  
500 EXC US  
500 XC-W US

Art. no. 3206209en

**KTM**



Read this repair manual carefully and thoroughly before beginning work.

The vehicle will only be able to meet the demands placed on it if the specified service work is performed regularly and properly.

This repair manual was written to correspond to the latest state of this model series. We reserve the right to make changes in the interest of technical advancement without updating this repair manual at the same time.

We shall not provide a description of general workshop methods. Likewise, safety rules that apply in a workshop are not specified here. It is assumed that the repair work will be performed by a fully trained mechanic.

All specifications are non-binding. KTM Sportmotorcycle GmbH specifically reserves the right to modify or delete technical specifications, prices, colors, forms, materials, services, designs, equipment, etc., without prior notice and without specifying reasons, to adapt these to local conditions, as well as to stop production of a particular model without prior notice. KTM accepts no liability for delivery options, deviations from illustrations and descriptions, misprints, and other errors. The models portrayed partly contain special equipment that does not belong to the regular scope of supply.

© 2015 KTM Sportmotorcycle GmbH, Mattighofen Austria

All rights reserved

Reproduction, even in part, as well as copying of all kinds, is permitted only with the express written permission of the copyright owner.



ISO 9001(12 100 6061)

According to the international quality management standard ISO 9001, KTM uses quality assurance processes that lead to the maximum possible quality of the products.

Issued by: TÜV Management Service

REG. NO. 12 100 6061

KTM Sportmotorcycle GmbH

5230 Mattighofen, Austria



# TABLE OF CONTENTS

1	MEANS OF REPRESENTATION.....	6	6.12.16	Adjusting the play of the steering head bearing (EXC EU/AUS/US, XC-W).....	40
1.1	Symbols used.....	6	6.13	EXC Six Days.....	40
1.2	Formats used.....	6	6.13.1	Performing a fork service.....	40
2	SAFETY ADVICE.....	7	6.13.2	Disassembling the fork legs.....	41
2.1	Repair Manual.....	7	6.13.3	Removing the spring.....	43
2.2	Safety advice.....	7	6.13.4	Disassembling the cartridge.....	44
2.3	Degrees of risk and symbols.....	7	6.13.5	Disassembling the piston rod.....	45
2.4	Work rules.....	7	6.13.6	Disassembling the hydrostop unit.....	46
3	IMPORTANT NOTES.....	8	6.13.7	Disassembling the seal ring retainer.....	46
3.1	Guarantee, warranty.....	8	6.13.8	Checking the fork legs.....	47
3.2	Operating and auxiliary substances.....	8	6.13.9	Assembling the seal ring retainer.....	48
3.3	Spare parts, accessories.....	8	6.13.10	Assembling the hydrostop unit.....	48
3.4	Figures.....	8	6.13.11	Assembling the piston rod.....	49
4	SERIAL NUMBERS.....	9	6.13.12	Assembling the cartridge.....	50
4.1	Chassis number.....	9	6.13.13	Assembling the fork legs.....	51
4.2	Type label.....	9	6.13.14	Greasing the steering head bearing.....	55
4.3	Key number (All EXC models).....	9	6.13.15	Removing the lower triple clamp.....	55
4.4	Engine number.....	10	6.13.16	Installing the lower triple clamp.....	56
4.5	Fork part number.....	10	6.13.17	Checking the steering head bearing play.....	57
4.6	Shock absorber part number.....	10	6.13.18	Adjusting the play of the steering head bearing.....	58
5	MOTORCYCLE.....	11	7	HANDLEBAR, CONTROLS.....	59
5.1	Raising the motorcycle with the lift stand.....	11	7.1	Handlebar position.....	59
5.2	Removing the motorcycle from the lift stand.....	11	7.2	Adjusting handlebar position.....	59
5.3	Starting.....	11	7.3	Adjusting the basic position of the clutch lever.....	59
5.4	Starting the motorcycle for a check.....	12	7.4	Checking throttle cable routing.....	60
6	FORK, TRIPLE CLAMP.....	13	7.5	Checking the play in the throttle cable.....	60
6.1	Adjusting the compression damping of the fork.....	13	7.6	Adjusting the play in the throttle cable.....	61
6.2	Adjusting the rebound damping of the fork.....	13	8	FRAME.....	63
6.3	Adjusting the spring preload of the fork (EXC EU/AUS/US, XC-W, EXC Factory Edition).....	15	8.1	Checking the frame.....	63
6.4	Bleeding the fork legs.....	15	8.2	Removing the engine guard (EXC AU, EXC Factory Edition, EXC Six Days).....	63
6.5	Cleaning the dust boots of the fork legs.....	16	8.3	Installing the engine guard (EXC AU, EXC Factory Edition, EXC Six Days).....	63
6.6	Loosening the fork protector.....	17	9	SHOCK ABSORBER, SWINGARM.....	64
6.7	Positioning the fork protector.....	17	9.1	Adjusting the high-speed compression damping of the shock absorber.....	64
6.8	Removing the fork legs.....	18	9.2	Adjusting the low-speed compression damping of the shock absorber.....	64
6.9	Installing the fork legs.....	18	9.3	Adjusting the rebound damping of the shock absorber.....	65
6.10	Removing the fork protector.....	20	9.4	Measuring rear wheel sag unloaded.....	65
6.11	Installing the fork protector.....	20	9.5	Checking the static sag of the shock absorber....	65
6.12	EXC EU/AUS/US, XC-W, EXC Factory Edition.....	21	9.6	Checking the riding sag of the shock absorber....	66
6.12.1	Performing a fork service.....	21	9.7	Adjusting the spring preload of the shock absorber.....	66
6.12.2	Disassembling the fork legs.....	21	9.8	Adjusting the riding sag.....	67
6.12.3	Cartridge disassembly.....	24	9.9	Removing the shock absorber.....	67
6.12.4	Disassembling the compression damping fitting.....	26	9.10	Installing the shock absorber.....	68
6.12.5	Checking the fork legs.....	26	9.11	Servicing the shock absorber.....	68
6.12.6	Assembling the compression damping fitting.....	27	9.12	Removing the spring.....	69
6.12.7	Assembling the cartridge.....	28	9.13	Disassembling the damper.....	69
6.12.8	Assembling the fork legs.....	29	9.14	Disassembling the piston rod.....	71
6.12.9	Greasing the steering head bearing.....	33	9.15	Disassembling the seal ring retainer.....	72
6.12.10	Removing the lower triple clamp (EXC Factory Edition).....	34	9.16	Replacing the pilot bushing.....	73
6.12.11	Installing the lower triple clamp (EXC Factory Edition).....	34	9.17	Checking the damper.....	73
6.12.12	Removing the lower triple clamp (EXC EU/AUS/US, XC-W).....	36	9.18	Disassembling the rebound adjuster.....	74
6.12.13	Installing the lower triple clamp (EXC EU/AUS/US, XC-W).....	37	9.19	Removing the heim joint.....	75
6.12.14	Checking the steering head bearing play.....	39	9.20	Installing the heim joint.....	75
6.12.15	Adjusting the play of the steering head bearing (EXC Factory Edition).....	39	9.21	Assembling the rebound adjuster.....	76
			9.22	Assembling the seal ring retainer.....	77

# TABLE OF CONTENTS

9.23	Assembling the piston rod.....	77	15.3	Changing the fuses of individual power consumers.....	116
9.24	Assembling the damper .....	79	15.4	Removing the battery .....	117
9.25	Bleeding and filling the damper .....	81	15.5	Installing the battery .....	118
9.26	Filling the damper with nitrogen .....	83	15.6	Checking the charging voltage.....	118
9.27	Installing the spring .....	84	15.7	Checking the quiescent current .....	118
9.28	Changing the heim joint.....	85	16	<b>BRAKE SYSTEM</b> .....	120
10	<b>EXHAUST</b> .....	87	16.1	Checking the front brake linings .....	120
10.1	Removing the manifold.....	87	16.2	Changing the front brake linings.....	120
10.2	Installing the manifold .....	87	16.3	Checking free travel of hand brake lever .....	122
10.3	Removing main silencer.....	88	16.4	Adjusting free travel of hand brake lever (All EXC models).....	122
10.4	Installing the main silencer.....	88	16.5	Adjusting the basic position of the hand brake lever (XC-W) .....	122
10.5	Changing glass fiber yarn filling in the main silencer.....	88	16.6	Checking the brake fluid level of the front brake.....	123
11	<b>AIR FILTER</b> .....	90	16.7	Adding front brake fluid.....	123
11.1	Removing the air filter box cover .....	90	16.8	Changing the front brake fluid.....	124
11.2	Installing the air filter box cover .....	90	16.9	Checking the rear brake linings .....	125
11.3	Sealing the air filter box .....	90	16.10	Changing the rear brake linings .....	125
11.4	Removing the air filter.....	91	16.11	Checking the free travel of foot brake lever .....	127
11.5	Installing the air filter.....	91	16.12	Adjusting the basic position of the foot brake lever .....	127
11.6	Cleaning the air filter and air filter box.....	91	16.13	Checking the rear brake fluid level.....	128
12	<b>FUEL TANK, SEAT, TRIM</b> .....	93	16.14	Adding rear brake fluid .....	128
12.1	Opening filler cap .....	93	16.15	Changing the rear brake fluid .....	129
12.2	Closing filler cap.....	93	17	<b>LIGHTING SYSTEM, INSTRUMENTS</b> .....	131
12.3	Removing the seat .....	93	17.1	Checking the headlight setting .....	131
12.4	Mounting the seat .....	94	17.2	Adjusting the headlight range.....	131
12.5	Removing the fuel tank.....	94	17.3	Speedometer overview .....	132
12.6	Installing the fuel tank .....	95	17.4	Activation and test .....	132
12.7	Changing the fuel screen .....	97	17.5	Setting kilometers or miles.....	132
12.8	Changing the fuel filter.....	98	17.6	Setting the speedometer functions.....	133
12.9	Changing the fuel pump .....	100	17.7	Setting the clock.....	133
12.10	Checking the fuel pressure.....	101	17.8	Activating the additional functions.....	133
13	<b>MASK, FENDER</b> .....	103	17.9	Setting the wheel circumference .....	134
13.1	Removing the front fender .....	103	17.10	Viewing the lap time.....	134
13.2	Installing the front fender .....	103	18	<b>ENGINE</b> .....	136
13.3	Removing headlight mask with headlight.....	103	18.1	Removing the engine .....	136
13.4	Refitting the headlight mask with the headlight.....	104	18.2	Installing the engine.....	140
14	<b>WHEELS</b> .....	106	18.3	Engine disassembly.....	145
14.1	Checking the tire air pressure.....	106	18.3.1	Preparations.....	145
14.2	Checking the tire condition .....	106	18.3.2	Draining the engine oil .....	145
14.3	Checking the brake discs .....	107	18.3.3	Removing the clutch push rod.....	146
14.4	Checking spoke tension .....	107	18.3.4	Removing the oil filter .....	146
14.5	Front wheel .....	108	18.3.5	Removing the starter motor .....	147
14.5.1	Removing the front wheel .....	108	18.3.6	Removing the kickstarter .....	147
14.5.2	Installing the front wheel.....	108	18.3.7	Removing the spark plug .....	147
14.5.3	Removing the front brake disc.....	109	18.3.8	Removing the valve cover.....	147
14.5.4	Installing the front brake disc .....	109	18.3.9	Removing the alternator cover .....	148
14.6	Rear wheel .....	109	18.3.10	Positioning the engine at ignition top dead center.....	148
14.6.1	Removing the rear wheel .....	109	18.3.11	Removing the timing chain tensioner .....	149
14.6.2	Installing the rear wheel .....	110	18.3.12	Removing the camshaft .....	149
14.6.3	Removing the rear brake disc .....	111	18.3.13	Removing the cylinder head .....	149
14.6.4	Installing the rear brake disc.....	111	18.3.14	Removing the piston .....	150
14.6.5	Checking the chain tension.....	112	18.3.15	Removing the rotor.....	150
14.6.6	Adjusting the chain tension .....	112	18.3.16	Removing the timing chain guide rail .....	150
14.6.7	Checking the chain, rear sprocket, engine sprocket and chain guide.....	113	18.3.17	Removing the timing chain tensioning rail .....	151
14.6.8	Checking for chain dirt accumulation.....	115	18.3.18	Removing the timing chain securing guide .....	151
14.6.9	Cleaning the chain.....	115			
15	<b>WIRING HARNESS, BATTERY</b> .....	116			
15.1	Removing the main fuse .....	116			
15.2	Installing the main fuse.....	116			

18.3.19	Removing the timing chain .....	151	18.4.29	Checking valve spring seat .....	174
18.3.20	Removing the ignition pulse generator .....	151	18.4.30	Checking the cylinder head .....	174
18.3.21	Removing the suction pump .....	151	18.4.31	Checking the rocker arm shafts .....	175
18.3.22	Removing the water pump cover .....	152	18.4.32	Installing the valves .....	175
18.3.23	Removing the clutch cover .....	152	18.4.33	Installing the rocker arm .....	176
18.3.24	Removing the clutch discs .....	153	18.4.34	Checking the clutch .....	176
18.3.25	Removing the primary gear nut .....	154	18.4.35	Checking the shift mechanism .....	178
18.3.26	Removing the outer clutch hub .....	154	18.4.36	Preassembling the shift shaft .....	179
18.3.27	Removing the torque limiter .....	155	18.4.37	Disassembling the main shaft .....	179
18.3.28	Removing the starter idler gear .....	155	18.4.38	Assembling the main shaft .....	180
18.3.29	Removing the kickstarter idler gear .....	155	18.4.39	Disassembling the countershaft .....	181
18.3.30	Removing the kickstarter idler gear .....	155	18.4.40	Assembling the countershaft .....	181
18.3.31	Removing the shift shaft .....	155	18.4.41	Checking the transmission .....	182
18.3.32	Removing the shift drum locating unit .....	156	18.4.42	Premounting the kickstarter shaft .....	184
18.3.33	Removing the locking lever .....	156	18.4.43	Checking the starter drive .....	185
18.3.34	Removing the oil pump gear wheels .....	156	18.4.44	Removing the freewheel .....	185
18.3.35	Removing the force pump .....	157	18.4.45	Checking the freewheel .....	186
18.3.36	Removing the primary gear .....	157	18.4.46	Installing the freewheel .....	186
18.3.37	Removing the freewheel gear .....	157	18.5	Engine assembly .....	187
18.3.38	Removing the left engine case section .....	157	18.5.1	Installing the crankshaft .....	187
18.3.39	Removing the shift rails .....	158	18.5.2	Installing the transmission shafts .....	187
18.3.40	Removing the shift drum .....	158	18.5.3	Installing the shift forks .....	187
18.3.41	Removing the shift forks .....	159	18.5.4	Installing the shift drum .....	188
18.3.42	Removing the transmission shafts .....	159	18.5.5	Installing the shift rails .....	188
18.3.43	Removing the crankshaft .....	159	18.5.6	Installing the left engine case .....	188
18.4	Work on individual parts .....	160	18.5.7	Installing the freewheel gear .....	189
18.4.1	Work on the right section of the engine case .....	160	18.5.8	Installing the primary gear .....	189
18.4.2	Work on the left section of the engine case .....	161	18.5.9	Installing the force pump .....	189
18.4.3	Removing the oil pressure regulator valve .....	162	18.5.10	Installing the oil pump gear wheels .....	190
18.4.4	Checking spring length of oil pressure regulator valve .....	162	18.5.11	Installing the locking lever .....	190
18.4.5	Installing the oil pressure regulator valve .....	163	18.5.12	Installing the shift drum locating unit .....	190
18.4.6	Removing the crankshaft seal ring in the clutch cover .....	163	18.5.13	Installing the shift shaft .....	191
18.4.7	Installing the crankshaft seal ring in the clutch cover .....	163	18.5.14	Installing the kickstarter idler gear .....	191
18.4.8	Removing the water pump .....	163	18.5.15	Installing the kickstarter shaft .....	191
18.4.9	Installing the water pump .....	164	18.5.16	Installing the starter idler gear .....	191
18.4.10	Removing the timing chain sprocket .....	165	18.5.17	Installing the torque limiter .....	192
18.4.11	Installing the timing chain sprocket .....	165	18.5.18	Installing the outer clutch hub .....	192
18.4.12	Changing the connecting rod, conrod bearing, and crank pin .....	165	18.5.19	Installing the primary gear nut .....	193
18.4.13	Checking crankshaft run-out at bearing pin .....	167	18.5.20	Installing the clutch discs .....	193
18.4.14	Cylinder - Nikasil® coating .....	167	18.5.21	Installing the clutch cover .....	194
18.4.15	Checking/measuring the cylinder .....	167	18.5.22	Installing the water pump cover .....	195
18.4.16	Checking/measuring the piston .....	168	18.5.23	Installing the suction pump .....	195
18.4.17	Checking the piston ring end gap .....	168	18.5.24	Installing the ignition pulse generator .....	196
18.4.18	Measuring the piston/cylinder mounting clearance .....	169	18.5.25	Installing the timing chain .....	196
18.4.19	Checking the oil pumps .....	169	18.5.26	Installing the timing chain securing guide .....	196
18.4.20	Disassembling the autodecompressor .....	169	18.5.27	Installing the timing chain tensioning rail .....	197
18.4.21	Assembling the autodecompressor .....	170	18.5.28	Installing the timing chain guide rail .....	197
18.4.22	Checking camshaft .....	171	18.5.29	Installing the rotor .....	197
18.4.23	Checking the timing assembly .....	171	18.5.30	Installing the piston .....	197
18.4.24	Removing the rocker arm .....	172	18.5.31	Installing the cylinder head .....	199
18.4.25	Removing the valves .....	172	18.5.32	Installing the camshaft .....	200
18.4.26	Changing camshaft bearing .....	173	18.5.33	Installing the timing chain tensioner .....	200
18.4.27	Checking the valves .....	173	18.5.34	Checking the valve clearance .....	201
18.4.28	Checking valve springs .....	174	18.5.35	Adjusting the valve clearance .....	201
			18.5.36	Installing the alternator cover .....	201
			18.5.37	Installing the valve cover .....	202
			18.5.38	Installing the spark plug .....	202
			18.5.39	Installing the kickstarter .....	202
			18.5.40	Installing the starter motor .....	202
			18.5.41	Installing the oil filter .....	203
			18.5.42	Installing the clutch push rod .....	203

# TABLE OF CONTENTS

18.5.43	Installing the oil screen .....	203	28.2	Service work (as additional order) .....	233
18.5.44	Removing the engine from the engine assembly stand .....	204	29	WIRING DIAGRAM .....	234
19	CLUTCH .....	205	29.1	Page 1 of 8 (EXC EU, EXC Factory Edition) .....	234
19.1	Checking/correcting the fluid level of the hydraulic clutch .....	205	29.2	Page 2 of 8 (EXC EU, EXC Factory Edition) .....	236
19.2	Changing the hydraulic clutch fluid .....	205	29.3	Page 3 of 8 (EXC EU, EXC Factory Edition) .....	238
20	WATER PUMP, COOLING SYSTEM .....	207	29.4	Page 4 of 8 (EXC EU, EXC Factory Edition) .....	240
20.1	Cooling system .....	207	29.5	Page 5 of 8 (EXC EU, EXC Factory Edition) .....	242
20.2	Checking the antifreeze and coolant level .....	207	29.6	Page 6 of 8 (EXC EU, EXC Factory Edition) .....	244
20.3	Checking the coolant level .....	208	29.7	Page 7 of 8 (EXC EU, EXC Factory Edition) .....	246
20.4	Draining the coolant .....	208	29.8	Page 8 of 8 (EXC EU, EXC Factory Edition) .....	248
20.5	Refilling coolant .....	209	29.9	Page 1 of 8 (EXC AU) .....	250
21	LUBRICATION SYSTEM .....	210	29.10	Page 2 of 8 (EXC AU) .....	252
21.1	Oil circuit .....	210	29.11	Page 3 of 8 (EXC AU) .....	254
21.2	Checking the engine oil level .....	210	29.12	Page 4 of 8 (EXC AU) .....	256
21.3	Changing the engine oil and oil filter, cleaning the oil screens .....	211	29.13	Page 5 of 8 (EXC AU) .....	258
21.4	Adding engine oil .....	213	29.14	Page 6 of 8 (EXC AU) .....	260
21.5	Checking the engine oil pressure .....	213	29.15	Page 7 of 8 (EXC AU) .....	262
22	IGNITION SYSTEM .....	215	29.16	Page 8 of 8 (EXC AU) .....	264
22.1	Ignition coil - checking the secondary winding .....	215	29.17	Page 1 of 8 (500 EXC US) .....	266
22.2	Checking the spark plug connector .....	215	29.18	Page 2 of 8 (500 EXC US) .....	268
22.3	Alternator - checking the stator winding .....	215	29.19	Page 3 of 8 (500 EXC US) .....	270
22.4	Removing the stator .....	216	29.20	Page 4 of 8 (500 EXC US) .....	272
22.5	Installing the stator .....	216	29.21	Page 5 of 8 (500 EXC US) .....	274
23	ELECTRIC STARTER .....	217	29.22	Page 6 of 8 (500 EXC US) .....	276
23.1	Checking the starter motor .....	217	29.23	Page 7 of 8 (500 EXC US) .....	278
24	THROTTLE VALVE BODY .....	218	29.24	Page 8 of 8 (500 EXC US) .....	280
24.1	Adjusting the idle speed .....	218	29.25	Page 1 of 8 (EXC Six Days) .....	282
24.2	Throttle position sensor circuit A - checking the basic settings .....	218	29.26	Page 2 of 8 (EXC Six Days) .....	284
24.3	Throttle position sensor - adjusting the basic settings .....	219	29.27	Page 3 of 8 (EXC Six Days) .....	286
24.4	Executing the initialization run .....	219	29.28	Page 4 of 8 (EXC Six Days) .....	288
25	TECHNICAL DATA .....	221	29.29	Page 5 of 8 (EXC Six Days) .....	290
25.1	Engine .....	221	29.30	Page 6 of 8 (EXC Six Days) .....	292
25.2	Engine tolerance, wear limits .....	221	29.31	Page 7 of 8 (EXC Six Days) .....	294
25.3	Engine tightening torques .....	222	29.32	Page 8 of 8 (EXC Six Days) .....	296
25.4	Capacities .....	224	29.33	Page 1 of 6 (XC-W) .....	298
25.4.1	Engine oil .....	224	29.34	Page 2 of 6 (XC-W) .....	300
25.4.2	Coolant .....	224	29.35	Page 3 of 6 (XC-W) .....	302
25.4.3	Fuel .....	224	29.36	Page 4 of 6 (XC-W) .....	304
25.5	Chassis .....	224	29.37	Page 5 of 6 (XC-W) .....	306
25.6	Electrical system .....	225	29.38	Page 6 of 6 (XC-W) .....	308
25.7	Tires .....	225	30	SUBSTANCES .....	310
25.8	Fork .....	225	31	AUXILIARY SUBSTANCES .....	311
25.8.1	EXC EU/AUS/US, XC-W, EXC Factory Edition .....	225	32	SPECIAL TOOLS .....	313
25.8.2	EXC Six Days .....	226	33	STANDARDS .....	327
25.9	Shock absorber .....	226	34	LIST OF ABBREVIATIONS .....	328
25.10	Chassis tightening torques .....	227	INDEX .....	329	
26	CLEANING, CARE .....	229			
26.1	Cleaning the motorcycle .....	229			
26.2	Checks and maintenance steps for winter operation .....	230			
27	STORAGE .....	231			
27.1	Storage .....	231			
27.2	Preparing for use after storage .....	231			
28	SERVICE SCHEDULE .....	232			
28.1	Service schedule .....	232			

## 1.1 Symbols used

The meaning of specific symbols is described below.



Indicates an expected reaction (e.g. of a work step or a function).



Indicates an unexpected reaction (e.g. of a work step or a function).



Indicates a page reference (more information is provided on the specified page).



Indicates information with more details or tips.



Indicates the result of a testing step.



Denotes a voltage measurement.



Denotes a current measurement.



Denotes a resistance measurement.

## 1.2 Formats used

The typographical formats used in this document are explained below.

<b>Proprietary name</b>	Identifies a proprietary name.
<b>Name®</b>	Identifies a protected name.
<b>Brand™</b>	Identifies a trademark.
<b><u>Underlined terms</u></b>	Refer to technical details of the vehicle or indicate technical terms, which are explained in the glossary.



### 2.1 Repair Manual

Read this Repair Manual carefully and thoroughly before beginning work. It contains useful information and tips that will help you repair and maintain your vehicle.

This manual assumes that the necessary special KTM tools and KTM workplace and workshop equipment are available.

### 2.2 Safety advice

A number of safety instructions need to be followed to operate the vehicle safely. Therefore, read this manual carefully. The safety instructions are highlighted in the text and are referred to at the relevant passages.

---

 **Info**  
The vehicle has various information and warning labels at prominent locations. Do not remove information/warning labels. If they are missing, you or others may not recognize dangers and may therefore be injured.

---

### 2.3 Degrees of risk and symbols

 **Danger**  
Indicates a danger that will immediately and invariably lead to fatal or serious permanent injury if the appropriate measures are not taken.

 **Warning**  
Indicates a danger that is likely to lead to fatal or serious injury if the appropriate measures are not taken.

 **Caution**  
Indicates a danger that may lead to minor injuries if the appropriate measures are not taken.

**Note**  
Indicates a danger that will lead to considerable machine and material damage if the appropriate measures are not taken.

 **Warning**  
Indicates a danger that will lead to environmental damage if the appropriate measures are not taken.

---

### 2.4 Work rules

Special tools are necessary for certain tasks. The tools are not contained in the vehicle but can be ordered under the number in parentheses. E.g.: bearing puller (15112017000)

During assembly, non-reusable parts (e.g. self-locking screws and nuts, seals and seal rings, O-rings, pins, lock washers) must be replaced by new parts.

In some instances, a thread locker (e.g. **Loctite**<sup>®</sup>) is required. The manufacturer instructions for use must be followed.

After disassembly, clean the parts that are to be reused and check them for damage and wear. Change damaged or worn parts.

After you complete the repair or service work, check the operating safety of the vehicle.

### 3.1 Guarantee, warranty

The work prescribed in the service schedule must be carried out by an authorized KTM workshop only and confirmed in the customer's Service & Warranty Booklet and in the **KTM Dealer.net**; otherwise, all warranty claims will be void. No warranty claims can be considered for damage resulting from manipulations and/or alterations to the vehicle.

Additional information on the guarantee or warranty and the procedures involved can be found in the Service & Warranty Booklet.

### 3.2 Operating and auxiliary substances



#### Warning

**Environmental hazard** Improper handling of fuel is a danger to the environment.

- Do not allow fuel to get into the ground water, the ground, or the sewage system.

Use the operating and auxiliary substances (such as fuel and lubricants) as specified in the manual.

### 3.3 Spare parts, accessories

Only use spare parts and accessories approved and/or recommended by KTM. KTM accepts no liability for other products and any resulting damage or loss.

The current **KTM PowerParts** for your vehicle can be found on the KTM website.

International KTM Website: <http://www.ktm.com>

### 3.4 Figures

The figures contained in the manual may depict special equipment.

In the interest of clarity, some components may be shown disassembled or may not be shown at all. It is not always necessary to disassemble the component to perform the activity in question. Please follow the instructions in the text.

## 4.1 Chassis number

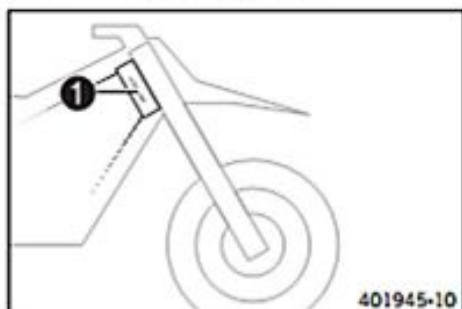

The chassis number ❶ is stamped on the steering head on the right.

## 4.2 Type label

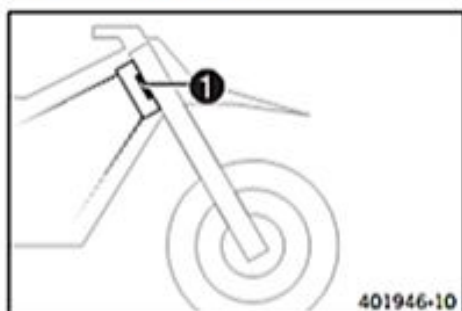

(EXC EU/AUS, EXC SIX DAYS, EXC Factory Edition, XC-W)

The type label ❶ is fixed to the front of the steering head.

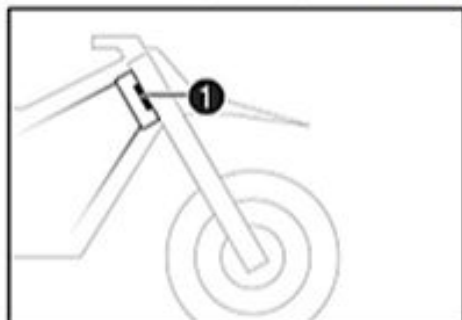

(500 EXC US)

The type label ❶ is fixed to the front of the steering head.

The additional type label for Canada ❷ is fixed to the front of the front pipe.

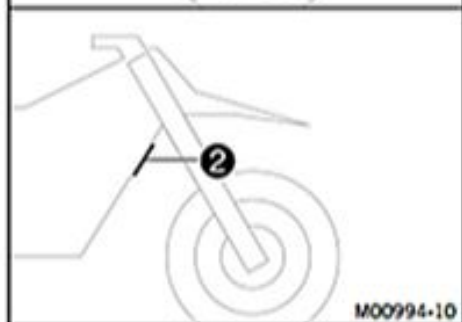

## 4.3 Key number (All EXC models)

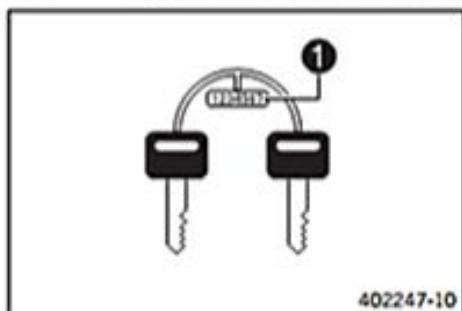

(EXC EU/AUS, EXC SIX DAYS, EXC Factory Edition)

The key number ❶ for the steering lock is stamped onto the key connector.

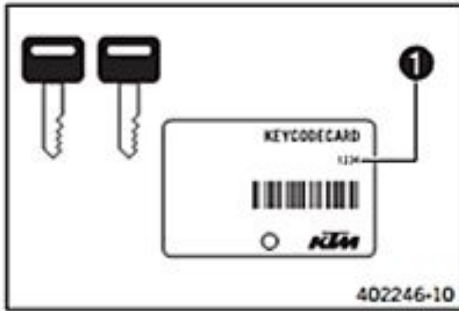

(500 EXC US)

Key number ① for the ignition and steering lock is indicated on the **KEYCODECARD**.



**Info**

You need the key number to order a replacement key. Keep the **KEYCODECARD** in a safe place.

## 4.4 Engine number

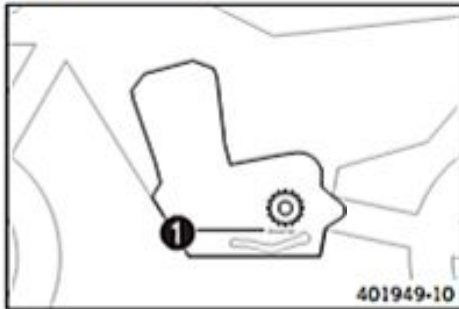

The engine number ① is stamped on the left side of the engine under the engine sprocket.

## 4.5 Fork part number

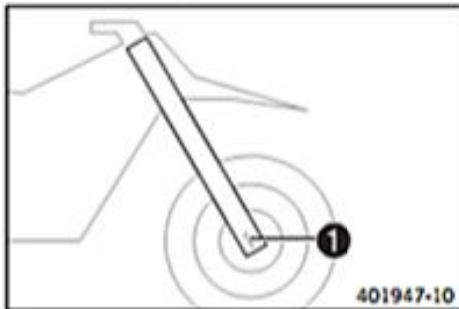

The fork part number ① is stamped on the inner side of the fork stub.

## 4.6 Shock absorber part number

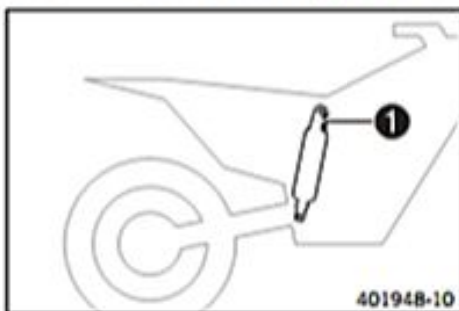

The shock absorber part number ① is stamped on the top of the shock absorber above the adjusting ring on the engine side.

## 5.1 Raising the motorcycle with the lift stand

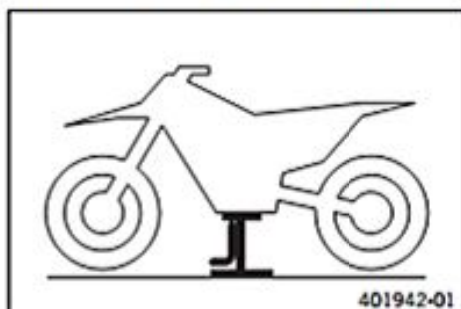

**Note**

**Danger of damage** The parked vehicle may roll away or fall over.

- Always place the vehicle on a firm and even surface.
- Raise the motorcycle at the frame underneath the engine.

Lift stand (54829055000) (☞ p. 315)

- ✓ Neither wheel is in contact with the ground.
- Secure the motorcycle against falling over.

## 5.2 Removing the motorcycle from the lift stand

**Note**

**Danger of damage** The parked vehicle may roll away or fall over.

- Always place the vehicle on a firm and even surface.

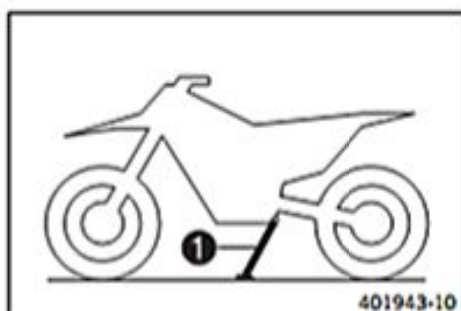

- Remove the motorcycle from the lift stand.
- Remove the lift stand.
- To park the motorcycle, press side stand ① to the ground with your foot and lean the motorcycle on it.

**i Info**

While riding, the side stand must be folded up and secured with the rubber band.

## 5.3 Starting



**Danger**

**Danger of poisoning** Exhaust gases are toxic and inhaling them may result in unconsciousness and/or death.

- When running the engine, always make sure there is sufficient ventilation, and do not start or run the engine in an enclosed space without an effective exhaust extraction system.

**Note**

**Engine failure** High engine speeds in cold engines have a negative effect on the service life of the engine.

- Always warm up the engine at low engine speeds.

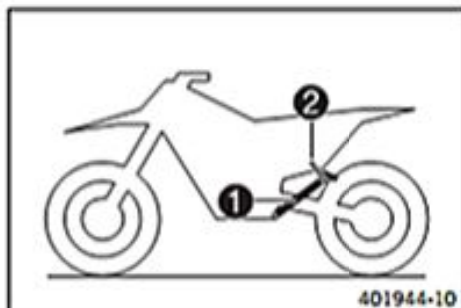

- Take the motorcycle off of side stand ① and secure the side stand with rubber band ②.
- Shift transmission to neutral.

**(500 EXC US)**

- Turn the key in the ignition lock to the position ☉.
- Turn the emergency OFF switch to the position ☉.

**(EXC AU)**

- Turn the emergency OFF switch to the position ☉.

**Condition**

Ambient temperature: < 20 °C (< 68 °F)

- Pull the idle speed adjusting screw all the way out.

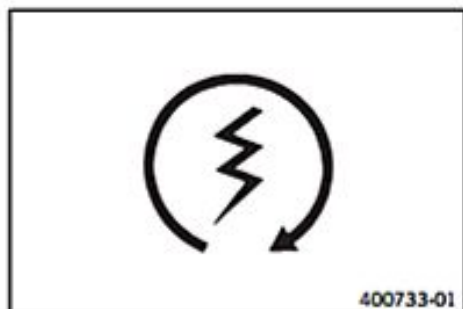

- Press the electric starter button or press the kick starter robustly through its full range.

**Info**

Press the electric starter button for at most 5 seconds. Wait for a least 5 seconds before trying again.  
Warning lamp FI lights up briefly as a functional control when starting.

### 5.4 Starting the motorcycle for a check

**Danger**

**Danger of poisoning** Exhaust gases are toxic and inhaling them may result in unconsciousness and/or death.



- When running the engine, always make sure there is sufficient ventilation, and do not start or run the engine in an enclosed space without an effective exhaust extraction system.

**Info**

Press the starter for a maximum of 5 seconds. Wait for at least 5 seconds before trying again.

- Shift transmission to neutral.

**(500 EXC US)**

- Turn the key in the ignition lock to the position .
- Turn the emergency OFF switch to the position .

**(EXC AU)**

- Turn the emergency OFF switch to the position .
- Press the electric starter button or press the kickstarter robustly through its full range.

**Info**

Do not open the throttle.

## 6.1 Adjusting the compression damping of the fork

**i** **Info**  
The hydraulic compression damping determines the fork suspension behavior.

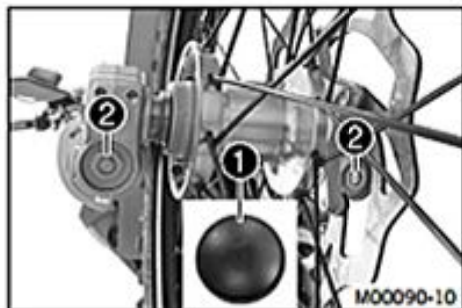

(EXC EU/AUS/US, XC-W, EXC Factory Edition)

- Remove protection caps **1**.
- Turn adjusting screws **2** clockwise all the way.

**i** **Info**  
Adjusting screws **2** are located at the bottom end of the fork legs. Make the same adjustment on both fork legs.

- Turn back counterclockwise by the number of clicks corresponding to the fork type.

Guideline

Compression damping	
Comfort	22 clicks
Standard	20 clicks
Sport	18 clicks

**i** **Info**  
Turn clockwise to increase damping; turn counterclockwise to reduce damping.

- Mount protection caps **1**.

(EXC Six Days)

- Turn the white adjusting screw **1** all the way clockwise.



**i** **Info**  
Adjusting screw **1** is located at the upper end of the left fork leg. The compression damping is located in the left fork leg **COMP** (white adjusting screw). The rebound damping is located in the right fork leg **REB** (red adjusting screw).

- Turn back counterclockwise by the number of clicks corresponding to the fork type.

Guideline

Compression damping	
Comfort	15 clicks
Standard	13 clicks
Sport	11 clicks

**i** **Info**  
Turn clockwise to increase damping; turn counterclockwise to reduce damping.

## 6.2 Adjusting the rebound damping of the fork

**i** **Info**  
The hydraulic rebound damping determines the fork suspension behavior.



**(EXC EU/AUS/US, XC-W)**

- Turn adjusting screws ❶ clockwise all the way.



**Info**

Adjusting screws ❶ are located at the top end of the fork legs. Make the same adjustment on both fork legs.

- Turn back counterclockwise by the number of clicks corresponding to the fork type.

**Guideline**

Rebound damping	
Comfort	20 clicks
Standard	18 clicks
Sport	16 clicks



**Info**

Turn clockwise to increase damping; turn counterclockwise to reduce damping.



**(EXC Factory Edition)**

- Turn adjusting screws ❶ clockwise all the way.



**Info**

Adjusting screws ❶ are located at the top end of the fork legs. Make the same adjustment on both fork legs.

- Turn back counterclockwise by the number of clicks corresponding to the fork type.

**Guideline**

Rebound damping	
Comfort	20 clicks
Standard	18 clicks
Sport	16 clicks



**Info**

Turn clockwise to increase damping; turn counterclockwise to reduce damping.



**(EXC Six Days)**

- Turn the red adjusting screw ❶ all the way clockwise.



**Info**

Adjusting screw ❶ is located at the upper end of the right fork leg. The rebound damping is located in the right fork leg **REB** (red adjusting screw). The compression damping is located in the left fork leg **COMP** (white adjusting screw).

- Turn back counterclockwise by the number of clicks corresponding to the fork type.

**Guideline**

Rebound damping	
Comfort	15 clicks
Standard	13 clicks
Sport	11 clicks



**Info**

Turn clockwise to increase damping; turn counterclockwise to reduce damping.



## 6.3 Adjusting the spring preload of the fork (EXC EU/AUS/US, XC-W, EXC Factory Edition)



(EXC EU/AUS/US, XC-W)

- Turn the adjusting screws counterclockwise all the way.

**Info**

Make the same adjustment on both fork legs.

- Turn clockwise by the number of turns corresponding to the fork type.

## Guideline

Spring preload - Preload Adjuster	
Comfort	1 turn
Standard	2 turns
Sport	2 turns

**Info**

Turn clockwise to increase the spring preload; turn counterclockwise to reduce the spring preload.

Adjusting the spring preload has no influence on the absorption setting of the rebound damping.

Basically, however, you should set the rebound damping higher with a higher spring preload.



(EXC Factory Edition)

- Turn the adjusting screws counterclockwise all the way.

**Info**

Make the same adjustment on both fork legs.

- Turn clockwise by the number of turns corresponding to the fork type.

## Guideline

Spring preload - Preload Adjuster	
Comfort	1 turn
Standard	2 turns
Sport	2 turns

**Info**

Turn clockwise to increase the spring preload; turn counterclockwise to reduce the spring preload.

Adjusting the spring preload has no influence on the absorption setting of the rebound damping.

Basically, however, you should set the rebound damping higher with a higher spring preload.

## 6.4 Bleeding the fork legs



## Preparatory work

- Raise the motorcycle with the lift stand. (↖ p. 11)

## Main work

(EXC EU/AUS/US, XC-W)

- Release bleeder screws ①.
- ✓ Any excess pressure escapes from the interior of the fork.
- Tighten the bleeder screws.

**(EXC Factory Edition)**

- Release bleeder screws ①.
- ✓ Any excess pressure escapes from the interior of the fork.
- Tighten the bleeder screws.

**(EXC Six Days)**

- Release bleeder screws ①.
- ✓ Any excess pressure escapes from the interior of the fork.
- Tighten the bleeder screws.

**Finishing work**

- Remove the motorcycle from the lift stand. (☞ p. 11)

**6.5 Cleaning the dust boots of the fork legs****Preparatory work**

- Raise the motorcycle with the lift stand. (☞ p. 11)
- Loosen the fork protector. (☞ p. 17)

**Main work****(EXC EU/AUS, EXC SIX DAYS, EXC Factory Edition)**

- Push dust boots ① of both fork legs downward.

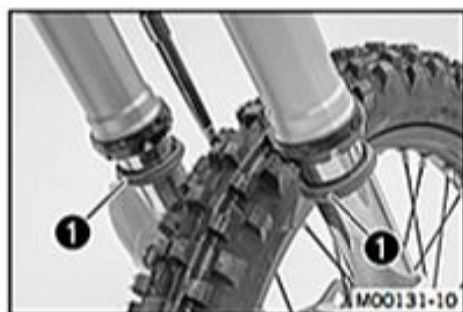
**Info**

The dust boots remove dust and coarse dirt particles from the inside fork tubes. Over time, dirt can penetrate behind the dust boots. If this dirt is not removed, the oil seals behind can start to leak.

**Warning**

**Danger of accidents** Reduced braking efficiency due to oil or grease on the brake discs.

- Always keep the brake discs free of oil and grease, and clean them with brake cleaner when necessary.

- Clean and oil the dust boots and inner fork tube of both fork legs.

Universal oil spray (☞ p. 312)

- Press the dust boots back into their normal position.
- Remove excess oil.

**(XC-W, 500 EXC US)**

- Push dust boots ① of both fork legs downward.

**Info**

The dust boots remove dust and coarse dirt particles from the inside fork tubes. Over time, dirt can penetrate behind the dust boots. If this dirt is not removed, the oil seals behind can start to leak.

**Warning**

**Danger of accidents** Reduced braking efficiency due to oil or grease on the brake discs.

- Always keep the brake discs free of oil and grease, and clean them with brake cleaner when necessary.



- Clean and oil the dust boots and inner fork tube of both fork legs.

Universal oil spray (☛ p. 312)

- Press the dust boots back into their normal position.
- Remove excess oil.

#### Finishing work

- Position the fork protector. (☛ p. 17)
- Remove the motorcycle from the lift stand. (☛ p. 11)

### 6.6 Loosening the fork protector



(EXC EU/AUS, EXC SIX DAYS, EXC Factory Edition, XC-W)

- Remove screws ① and take off the clamp.
- Remove screws ② on the left fork leg. Push the fork protection downwards.
- Remove the screws on the right fork leg. Push the fork protection downwards.



(500 EXC US)

- Remove screws ① and take off the clamp.
- Remove screws ② on the left fork leg. Push the fork protection downwards.
- Remove the screws on the right fork leg. Push the fork protection downwards.

### 6.7 Positioning the fork protector



(EXC EU/AUS, EXC SIX DAYS, EXC Factory Edition, XC-W)

- Position the fork protector on the left fork leg. Mount and tighten screws ①.

#### Guideline

Remaining screws, chassis	M6	10 Nm (7.4 lbf ft)
---------------------------	----	-----------------------

- Position the brake line, wiring harness, and clamp. Mount and tighten screws ②.
- Position the fork protector on the right fork leg. Mount and tighten the screws.

#### Guideline

Remaining screws, chassis	M6	10 Nm (7.4 lbf ft)
---------------------------	----	-----------------------



(500 EXC US)

- Position the fork protector on the left fork leg. Mount and tighten screws ①.

#### Guideline

Remaining screws, chassis	M6	10 Nm (7.4 lbf ft)
---------------------------	----	-----------------------

- Position the brake line, wiring harness, and clamp. Mount and tighten screws ②.
- Position the fork protector on the right fork leg. Mount and tighten the screws.

#### Guideline

Remaining screws, chassis	M6	10 Nm (7.4 lbf ft)
---------------------------	----	-----------------------

## 6.8 Removing the fork legs

## Preparatory work

- Remove the headlight mask with the headlight. (☞ p. 103)
- Raise the motorcycle with the lift stand. (☞ p. 11)
- Remove the front wheel. (☞ p. 108)

## Main work

- Remove screws ❶ and take off the clamp.
- Remove the cable binder(s).
- Remove screws ❷ and take off the brake caliper.
- Allow the brake caliper and brake line to hang tension-free to the side.

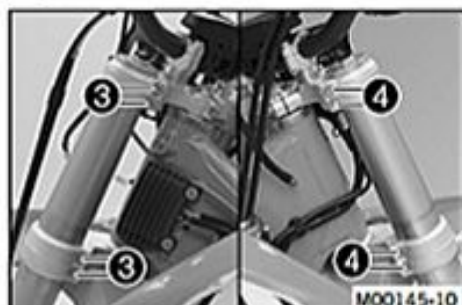
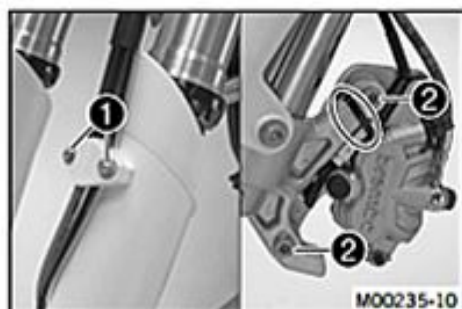

## (EXC EU, EXC AU, XC-W)

- Release screws ❸. Take out the left fork leg.
- Release screws ❹. Take out the right fork leg.

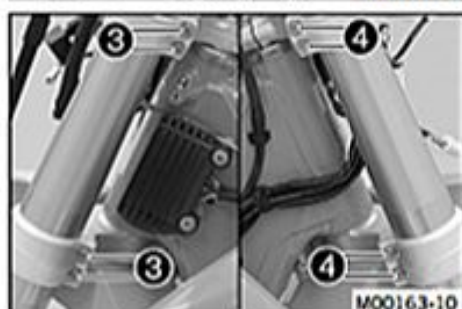

## (500 EXC US)

- Release screws ❸. Take out the left fork leg.
- Release screws ❹. Take out the right fork leg.

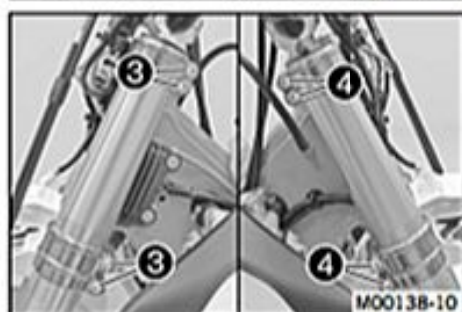

## (EXC Factory Edition, EXC Six Days)

- Release screws ❸. Take out the left fork leg.
- Release screws ❹. Take out the right fork leg.

## 6.9 Installing the fork legs



## Main work

## (EXC EU, EXC AU, XC-W)

- Position the fork legs.
- ✓ Bleeder screws ❶ are positioned toward the front.



## Info

Grooves are milled into the side of the upper end of the fork legs. The second milled groove (from the top) must be flush with the top edge of the upper triple clamp.

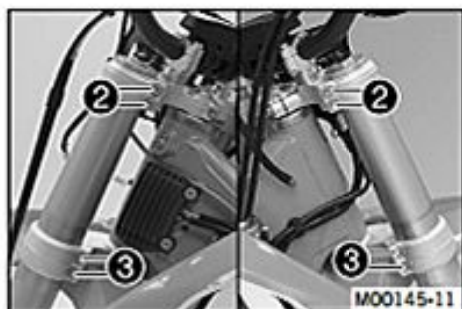

- Tighten screws ②.

## Guideline

Screw, top triple clamp	M8	20 Nm (14.8 lbf ft)
-------------------------	----	------------------------

- Tighten screws ③.

## Guideline

Screw, bottom triple clamp	M8	15 Nm (11.1 lbf ft)
----------------------------	----	------------------------

## (500 EXC US)

- Position the fork legs.
- ✓ Bleeder screws ① are positioned toward the front.



## Info

Grooves are milled into the side of the upper end of the fork legs. The second milled groove (from the top) must be flush with the top edge of the upper triple clamp.

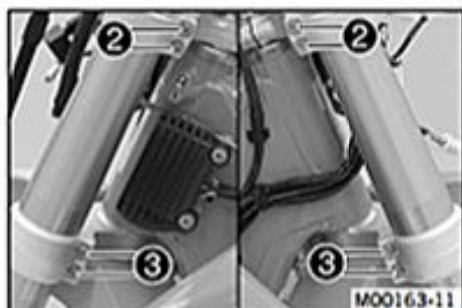
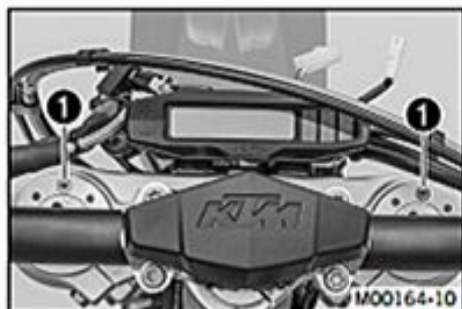

- Tighten screws ②.

## Guideline

Screw, top triple clamp	M8	20 Nm (14.8 lbf ft)
-------------------------	----	------------------------

- Tighten screws ③.

## Guideline

Screw, bottom triple clamp	M8	15 Nm (11.1 lbf ft)
----------------------------	----	------------------------

## (EXC Factory Edition)

- Position the fork legs.
- ✓ Bleeder screws ① are positioned toward the front.



## Info

Grooves are milled into the side of the upper end of the fork legs. The second milled groove (from the top) must be flush with the top edge of the upper triple clamp.

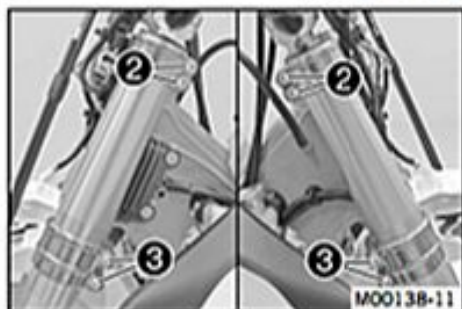

- Tighten screws ②.

## Guideline

Screw, top triple clamp	M8	17 Nm (12.5 lbf ft)
-------------------------	----	------------------------

- Tighten screws ③.

## Guideline

Screw, bottom triple clamp	M8	15 Nm (11.1 lbf ft)
----------------------------	----	------------------------

## (EXC Six Days)

- Position the fork legs.
- ✓ Bleeder screws ① are positioned toward the front.



## Info

The rebound damping is located in the right fork leg **REB** (red adjusting screw). The compression damping is located in the left fork leg **COMP** (white adjusting screw).

Grooves are milled into the side of the upper end of the fork legs. The second milled groove (from the top) must be flush with the top edge of the upper triple clamp.



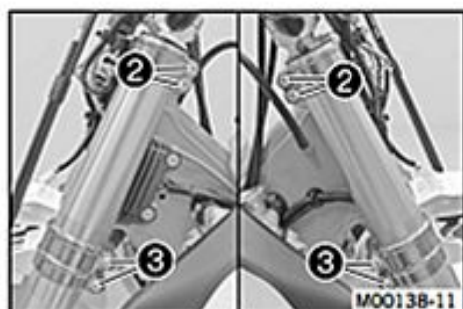

- Tighten screws ②.

## Guideline

Screw, top triple clamp	M8	17 Nm (12.5 lbf ft)
-------------------------	----	------------------------

- Tighten screws ③.

## Guideline

Screw, bottom triple clamp	M8	15 Nm (11.1 lbf ft)
----------------------------	----	------------------------

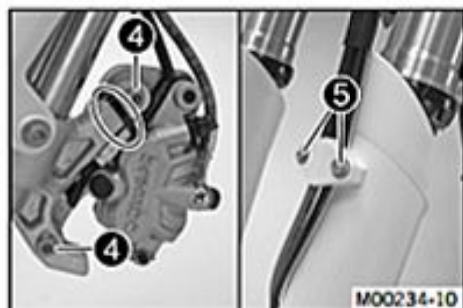

- Position the brake caliper and mount and tighten screws ④.

## Guideline

Screw, front brake caliper	M8	25 Nm (18.4 lbf ft)	Loctite® 243™
----------------------------	----	------------------------	---------------

- Mount cable binder.
- Position the brake line, wiring harness, and clamp. Mount and tighten screws ⑤.

## Finishing work

- Install the front wheel. (☛ p. 108)
- Refit the headlight mask with the headlight. (☛ p. 104)
- Check the headlight setting. (☛ p. 131)

## 6.10 Removing the fork protector

## Preparatory work

- Remove the headlight mask with the headlight. (☛ p. 103)
- Raise the motorcycle with the lift stand. (☛ p. 11)
- Remove the front wheel. (☛ p. 108)
- Remove the fork legs. (☛ p. 18)

## Main work

- Remove screws ① on the left fork leg. Remove the fork protector upwards.
- Remove the screws on the right fork leg. Remove the fork protector upwards.

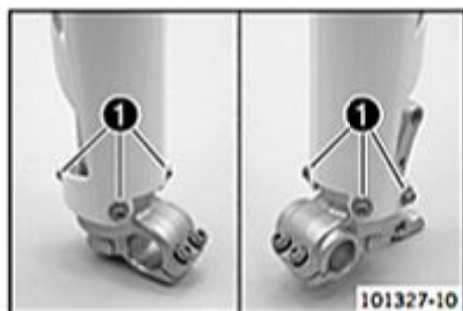

## 6.11 Installing the fork protector

## Main work

- Position the fork protector on the left fork leg. Mount and tighten screws ①.

## Guideline

Remaining screws, chassis	M6	10 Nm (7.4 lbf ft)
---------------------------	----	--------------------

- Position the fork protector on the right fork leg. Mount and tighten the screws.

## Guideline

Remaining screws, chassis	M6	10 Nm (7.4 lbf ft)
---------------------------	----	--------------------

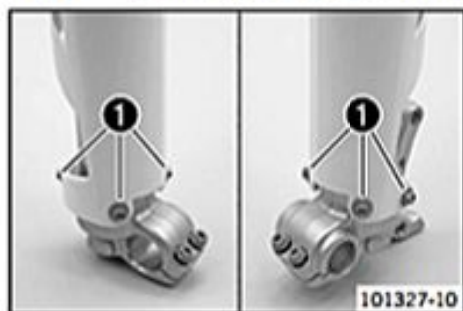

## Finishing work

- Install the fork legs. (☛ p. 18)
- Install the front wheel. (☛ p. 108)
- Refit the headlight mask with the headlight. (☛ p. 104)
- Check the headlight setting. (☛ p. 131)

## 6.12 EXC EU/AUS/US, XC-W, EXC Factory Edition

### 6.12.1 Performing a fork service

**i** Info  
These operations are the same on both fork legs.

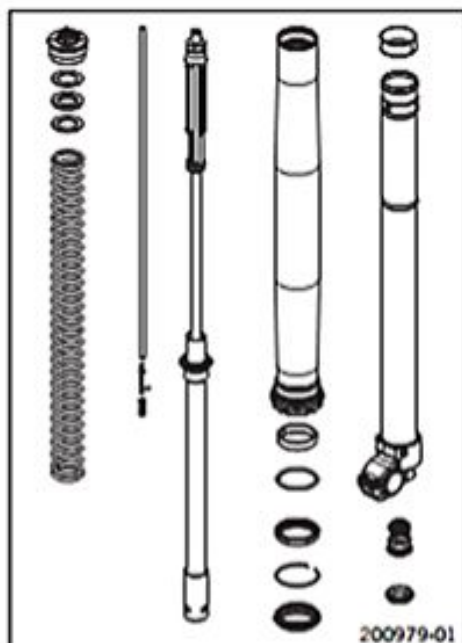

**Condition**

The fork legs have been removed.

- Disassemble the fork legs. (☛ p. 21)
- Disassemble the cartridge. (☛ p. 24)
- Check the fork legs. (☛ p. 26)
- Assemble the cartridge. (☛ p. 28)
- Assemble the fork legs. (☛ p. 29)

### 6.12.2 Disassembling the fork legs

**i** Info  
The steps are identical for both fork legs.

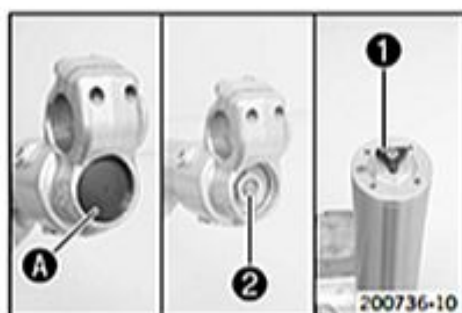

**Condition**

The fork legs are disassembled.

- Remove protective cover **A**.
- Note down the present state of rebound damping **1** and compression damping **2**.
- Note down of the present state of the spring preload.
- Completely open the adjusters of the rebound damping and compression damping.



- Clamp the fork leg in the area of lower triple clamp.

Clamping stand (T1403S) (☛ p. 325)



- Loosen Preload Adjuster ③.

Pin wrench (T103) (☞ p. 321)



**Info**

The Preload Adjuster cannot be taken off yet.



- Take out the fork leg and clamp with the axle clamp.



**Info**

Use soft jaws.

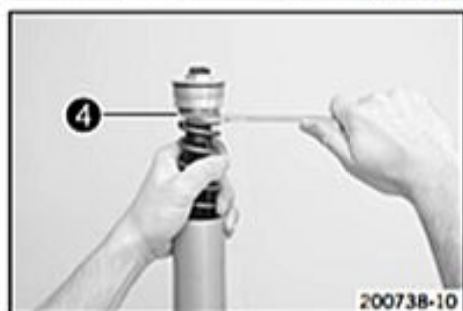

- Push the outer tube downward.
- Pull the spring downward. Place the special tool on the hexagonal part.

Open-end wrench (T14032) (☞ p. 325)



**Info**

The preload spacers ④ should be above the special tool.



- Clamp the special tool in the bench vise. Loosen Preload Adjuster ③.



- Remove Preload Adjuster ③ with preload spacers ④.
- Remove adjustment tube ⑤.



- Pull the spring downward. Remove the special tool.
- Remove the spring.





- Drain the fork oil.



**Info**

Pull out and push in the piston rod a few times to empty the cartridge.

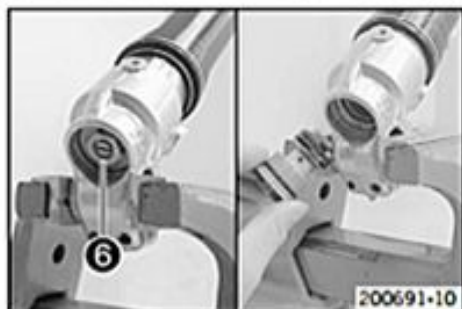

- Clamp the fork leg with the axle clamp.

**Guideline**

Use soft jaws.

- Unscrew and remove the compression damping fitting ⑥.



**Info**

Place a fluid collector beneath it, as usually some oil will drain out.



- Remove the cartridge.

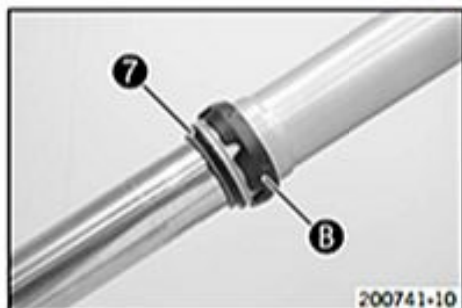

- Remove dust boot ⑦.
- Remove fork protector ring ⑧.



**Info**

The fork protector ring does not necessarily need to be disassembled for the further repair.

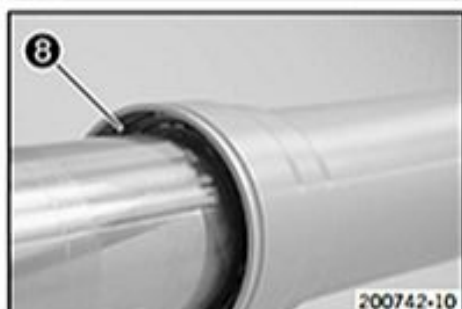

- Remove lock ring ⑧.



**Info**

The lock ring has a coarsely finished end against which the screwdriver can be placed.

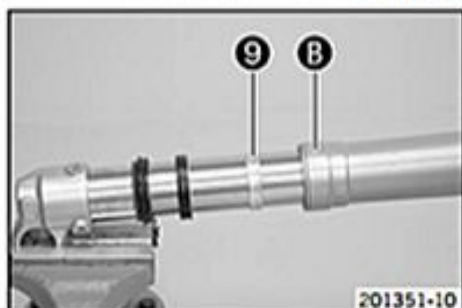

- Warm up the outer tube in area ⑧ of the lower sliding bushing.

**Guideline**

50 °C (122 °F)

- Jerk the outer tube out of the inner tube.



**Info**

The lower sliding bushing ⑨ must be pulled out of its bearing seat when doing this.



- Remove upper sliding bushing 10.



**Info**

Gently pull them apart without using any tool.



- Take off the lower sliding bushing 9.
- Take off support ring 11.
- Take off seal ring 12.
- Take off lock ring 8.
- Take off dust boot 7.
- Take out the fork leg.

### 6.12.3 Cartridge disassembly



**Info**

The steps are identical for both fork legs.

**Preparatory work**

- Disassemble the fork legs. (☛ p. 21)

**Main work**

- Remove fluid barrier 1 from the piston rod.

Clamping stand (T14016S) (☛ p. 324)



- Remove piston rod 2 from the cartridge.



- Remove washer 3 and spring seat 4 from the cartridge.

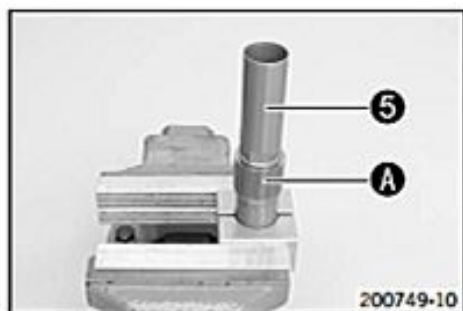

- Degrease the cartridge and clamp using the special tool.

Clamping stand (T14015S) (☛ p. 324)

- Warm up the cartridge in the area of **A**.

Guideline

50 °C (122 °F)

- Unscrew and remove screwsleeve **5**.

**i** Info

This step is unnecessary for the further disassembly.



- Degrease the piston rod.
- Clamp the piston rod with the special tool.

Clamping stand (T14016S) (☛ p. 324)

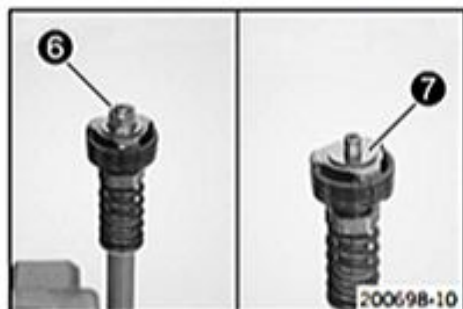

- Remove nut **6**.
- Remove shim stack **7** completely.



- Remove piston **8**.
- Remove shim stack **9** completely.

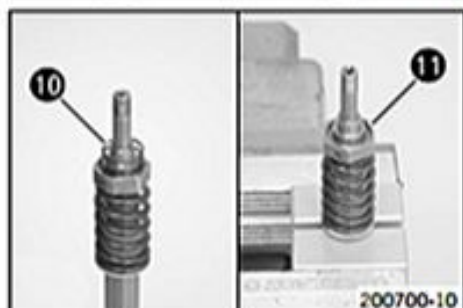

- Remove spring **10**.
- Remove tap rebound **11**.

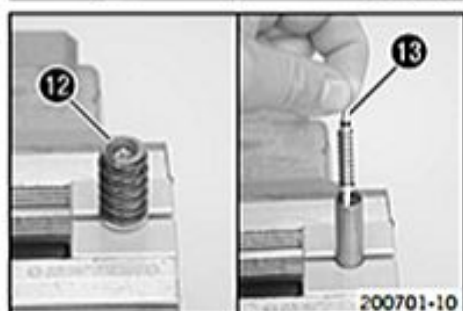

- Remove spring **12**.
- Remove valve **13** of the rebound damping together with the spring.
- Take out the piston rod.

## 6.12.4 Disassembling the compression damping fitting

**i** Info  
The steps are identical for both fork legs.

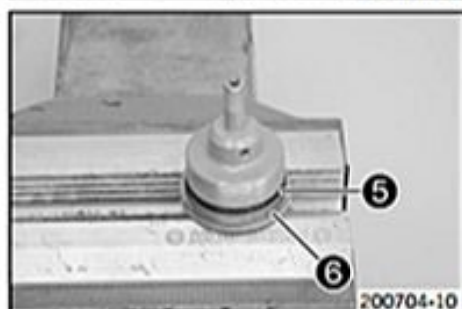
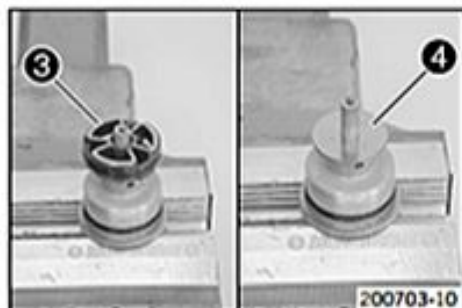
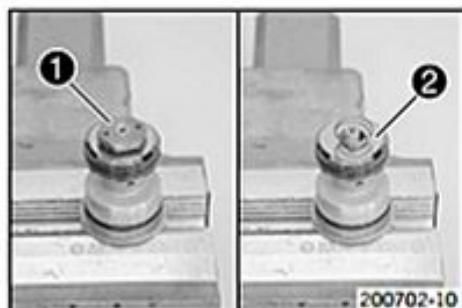
**Preparatory work**

- Disassemble the fork legs. (☛ p. 21)

**Main work**

- Clamp the compression damping fitting in a bench vise using soft jaws.
- Remove nut ①.
- Remove the spring.
- Remove washer ②.

- Remove piston ③.
- Remove shim stack ④.

- Remove O-ring ⑤ and seal ring ⑥ from the compression damping fitting.
- Extract the compression damping fitting.

## 6.12.5 Checking the fork legs

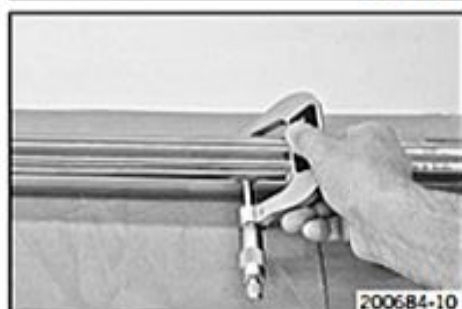
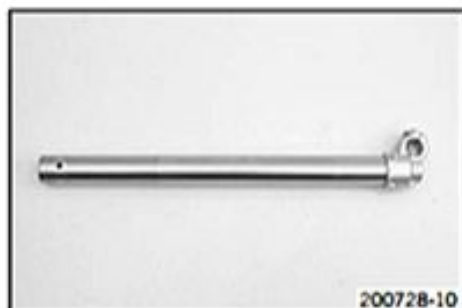
**Condition**

The fork legs must be disassembled.

- Check the inner tube and axle clamp for damage.
  - If there is damage:
    - Change the inner tube.

- Measure the outside diameter at several locations on the inner tube.

Outside diameter of the inner tube	47.975... 48.005 mm (1.88878... 1.88996 in)
------------------------------------	---

- If the measured value is below the specified value:
  - Change the inner tube.

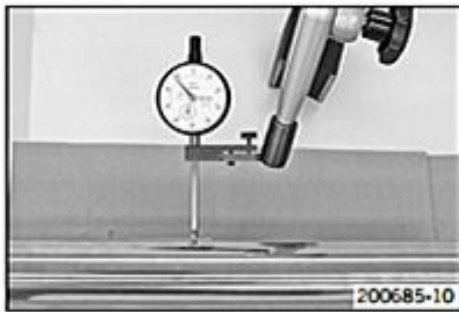

- Measure the run-out of the inner tube.

Inner tub run-out	≤ 0.20 mm (≤ 0.0079 in)
-------------------	-------------------------

- If the measured value is greater than the specified value:
  - Change the inner tube.

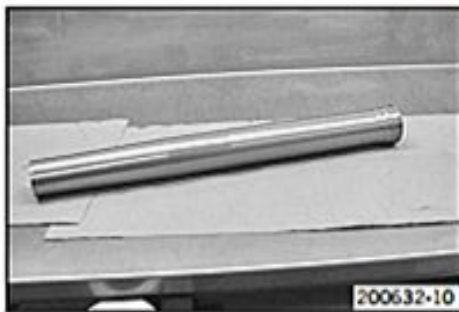

- Check the outer tube for damage.

- If there is damage:
  - Change the outer tube.



- Check the surface of the sliding bushing.

- If the bronze-colored layer **A** under the sliding layer **B** is visible:
  - Replace the sliding bushing.

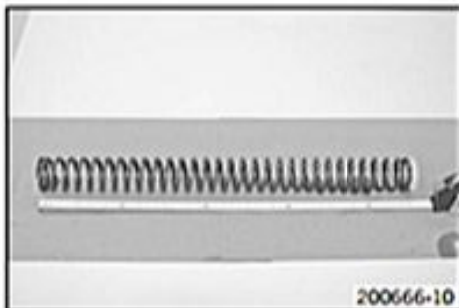

- Check the spring length.

**Guideline**

Spring length with preload spacer(s)	
Weight of rider: 65... 75 kg (143... 165 lb.)	513 mm (20.2 in)
Weight of rider: 75... 85 kg (165... 187 lb.)	513 mm (20.2 in)
Weight of rider: 85... 95 kg (187... 209 lb.)	513 mm (20.2 in)

- If the measured value is greater than the specified value:
  - Reduce the thickness of the preload spacer.
- If the measured value is less than the specified value:
  - Increase the thickness of the preload spacer.

### 6.12.6 Assembling the compression damping fitting



**Info**

The steps are identical for both fork legs.

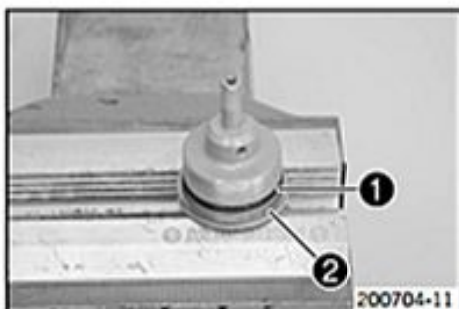

- Clamp the compression damping fitting in a bench vise using soft jaws.
- Mount O-ring **1** and seal ring **2**.
- Grease the O-ring.

Lubricant (T158) (☛ p. 311)
-----------------------------

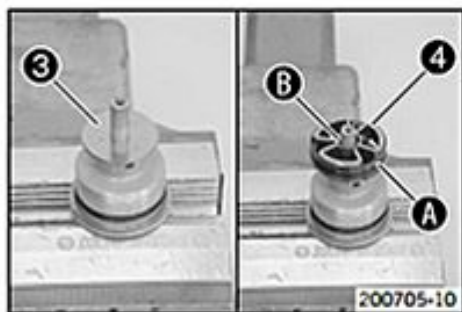

- Mount shim stack ③.

**i Info**  
Mount the smaller shims below.

- Mount pistons ④ with O-ring ①.

**i Info**  
The side with the largest inside diameter ② faces upward.

- Grease the piston O-ring.

Fork oil (SAE 4) (48601166S1) (☛ p. 310)

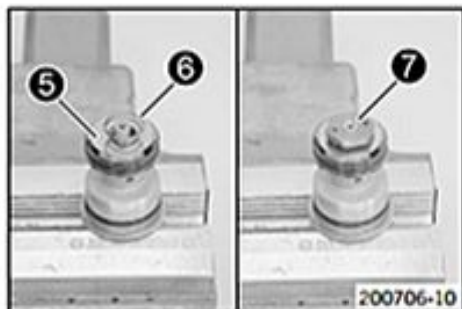

- Mount washer ⑤.
- Mount spring ⑥ with the tighter coil facing downward.
- Mount and tighten nut ⑦.

Guideline

Compression damping fitting nut	M6x0.5	3 Nm (2.2 lbf ft)
---------------------------------	--------	-------------------

**i Info**  
The washer ⑤ must have freedom of movement relative to the spring force.

- Secure the nut by locking.
- Extract the compression damping fitting.

## 6.12.7 Assembling the cartridge

**i Info**  
The steps are identical for both fork legs.

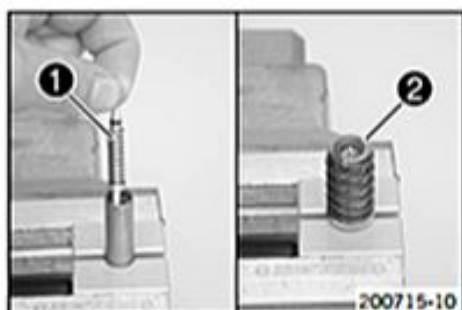

- Clamp in the piston rod.

Clamping stand (T14016S) (☛ p. 324)

- Mount valve ① of the rebound damping, with the spring and O-ring.
- Grease the O-ring.

Lubricant (T158) (☛ p. 311)

- Mount spring ②.



- Grease tap rebound ③ O-ring.

Lubricant (T158) (☛ p. 311)

- Mount and tighten the tap rebound.

Guideline

Tap rebound	M9x1	18 Nm (13.3 lbf ft)	Loctite® 2701™
-------------	------	------------------------	----------------

- Position spring ④.



- Mount shim stack ⑤.

**i Info**  
Mount the smaller shims below.

- Press the shim stack downward against the spring force.

**i Info**  
The shim stack must be pressed downward over the collar.

- Mount piston ⑥ with the piston ring.

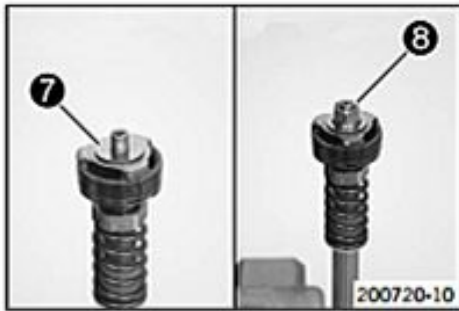

- Mount shim stack **7**.

**i Info**  
The side with the largest inside diameter faces downward.

**i Info**  
Align the triangular plate exactly with the piston opening.

- Mount and tighten nut **8**.

Guideline

Tap rebound nut	M6x0.5	5 Nm (3.7 lbf ft)
-----------------	--------	-------------------

**i Info**  
Mount the nut with the collar facing downward.

- Secure the nut by locking.
- Degrease the cartridge and clamp using the special tool.

Clamping stand (T14015S) (☛ p. 324)

- Mount and tighten screwsleeve **9**.

Guideline

Screwsleeve	M29x1	46 Nm (33.9 lbf ft)	Loctite® 241
-------------	-------	---------------------	--------------

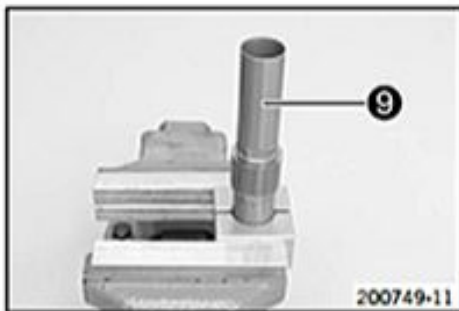

- Mount washer **10** and spring seat **11**.



- Push piston rod **12** into the cartridge.



- Screw on fluid barrier **13** to the stop.

**i Info**  
The fluid barrier must be screwed on tightly against the stop. Do not use a tool.

## 6.12.8 Assembling the fork legs

**i Info**  
The steps are identical for both fork legs.



**Preparatory work**

- Check the fork legs. (☞ p. 26)
- Assemble the cartridge. (☞ p. 28)
- Assemble the compression damping fitting. (☞ p. 27)

**Main work**

- Clamp in the inner tube with the axle clamp.

**Guideline**

Use soft jaws.

- Install the special tool.

Protecting sleeve (T1401) (☞ p. 324)

- Grease and slide on dust boot ①.

Lubricant (T511) (☞ p. 311)



**Info**

Always change the dust boot, seal ring, lock ring, and support ring. Mount the sealing lip with the spring expander facing downward.

- Slide on lock ring ②.
- Grease and slide on seal ring ③.

Lubricant (T511) (☞ p. 311)



**Info**

The sealing lip should face downward and the open side upward.

- Slide on support ring ④.
- Remove the special tool.
- Roughen, clean, and grease the edges of the sliding bushings using 600 grit sandpaper.

Fork oil (SAE 4) (48601166S1) (☞ p. 310)



- Slide on lower sliding bushing ⑤.
- Mount upper sliding bushing ⑥.



**Info**

Gently pull them apart without using any tool.



- Slide on the outer tube.
- Warm up the outer tube in the lower sliding bushing area of A.

**Guideline**

50 °C (122 °F)

- Hold the lower sliding bushing with the longer shoulder of the special tool.

Assembly tool (T1402S) (☞ p. 325)

- Press the outer tube all the way in.





- Position the support ring.
- Hold the seal ring with the shorter shoulder of the special tool.

Assembly tool (T1402S) (☞ p. 325)

- Press the outer tube all the way in.

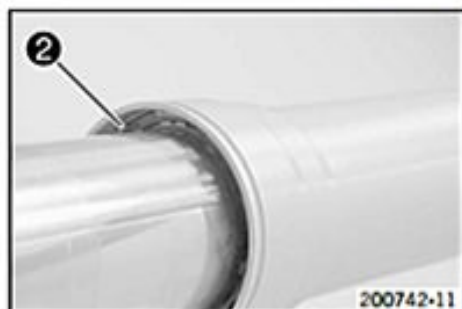

- Mount lock ring ②.

**Info**

The lock ring must audibly lock into place.

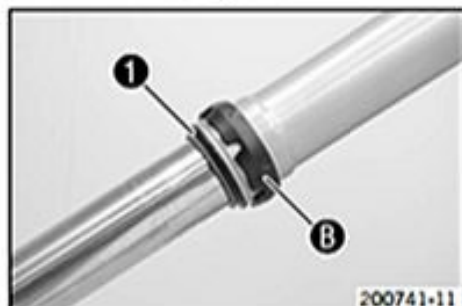

- Install dust boot ①.
- Mount fork protector ring ⑧.



- Mount adjustment tube ⑦ of the rebound damping in the cartridge.
  - ✓ The adjustment tube extends 5 mm (0.197 in) out from the cartridge and can be pressed inward against the spring force.
  - ✗ The adjustment tube extends more than 7 mm (0.276 in) out from the cartridge and cannot be pressed inward against the spring force.
- Screw on water excluder ③ to the stop.

**Info**

The water excluder must be screwed on tightly against the stop. Do not use a tool.

- Mount the special tool on the cartridge.

Gripping tool (T14026S1) (☞ p. 324)

**Info**

The special tool must be used in order that the adjustment tube is not raised. Otherwise, oil will reach the piston rod.



- Push the cartridge into the inner tube.
- Mount and tighten compression damping fitting ⑧.

**Guideline**

Compression damping fitting	M29x1	35 Nm (25.8 lbf ft)
-----------------------------	-------	------------------------

**Info**

If the cartridge turns as well, press the piston rod slightly to the side.



- Clamp in the fork vertically.
- Fill with fork oil.

Fork oil per fork leg	618 ml (20.89 fl. oz.)	Fork oil (SAE 4) (48601166S1) (☛ p. 310)
-----------------------	---------------------------	---

**i Info**  
Pull out the piston rod and push back in a number of times to bleed the cartridge.



- Remove pin **D** of the special tool.

Gripping tool (T14026S1) (☛ p. 324)

- Pull out the piston rod. Install the spring. Reinstall the pin.

Guideline

Spring rate	
Weight of rider: 65... 75 kg (143... 165 lb.)	4.2 N/mm (24 lb/in)
Weight of rider: 75... 85 kg (165... 187 lb.)	4.4 N/mm (25.1 lb/in)
Weight of rider: 85... 95 kg (187... 209 lb.)	4.6 N/mm (26.3 lb/in)



- Pull the spring downward. Place the special tool on the hexagonal part.

Open-end wrench (T14032) (☛ p. 325)

- Remove the special tool.

Gripping tool (T14026S1) (☛ p. 324)



- Clamp the special tool in the bench vise.

- Grease the thread of the piston rod.

Lubricant (T159) (☛ p. 311)

- Grease the upper edge **E** of the piston rod.

Lubricant (T158) (☛ p. 311)

- Screw the **Preload Adjuster** with preload spacer onto the piston rod.

**i Info**  
The **Preload Adjuster** must be screwed in all the way before the piston rod also begins to turn. In case of tight piston rod threads, it must be held to keep it from turning. If the **Preload Adjuster** is not screwed in all the way, the rebound adjustment will not function.

- Tighten the **Preload Adjuster**.

Guideline

<b>Preload Adjuster</b> on the piston rod	M12x1	25 Nm (18.4 lbf ft)
---	-------	------------------------

- Take pressure off of the special tool. Pull the spring downward and remove the special tool.





- Push the outer tube upward.
- Clamp the outer tube in the area of lower triple clamp.

Clamping stand (T1403S) (☞ p. 325)

- Grease the **Preload Adjuster** O-ring.

Lubricant (T158) (☞ p. 311)

- Screw on and tighten the **Preload Adjuster**.

Guideline

<b>Preload Adjuster</b> on the outer tube	M51x1.5	50 Nm (36.9 lbf ft)
---	---------	------------------------

Pin wrench (T103) (☞ p. 321)

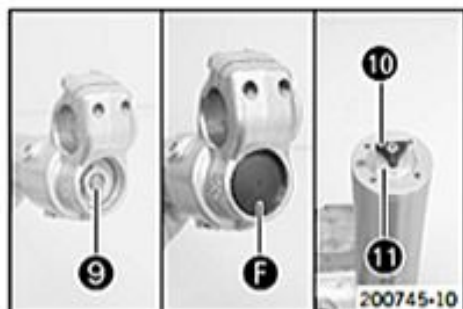

Alternative 1

- Turn adjusting screw of compression damping (9) and adjusting screw of rebound damping (10) clockwise all the way.
- Turn counterclockwise by the number of clicks corresponding to the fork type.

Guideline

Rebound damping	
Comfort	20 clicks
Standard	18 clicks
Sport	16 clicks
Compression damping	
Comfort	22 clicks
Standard	20 clicks
Sport	18 clicks

- Turn the adjusting screw of spring preload (11) counterclockwise all the way.
- Turn clockwise by the number of turns corresponding to the fork type.

Guideline

Spring preload - <b>Preload Adjuster</b>	
Comfort	1 turn
Standard	2 turns
Sport	2 turns

Alternative 2



### Warning

**Danger of accident** Modifications to the suspension setting may seriously alter the handling characteristic.

Extreme modifications to the suspension setting may cause a serious deterioration in the handling characteristic and overload components.

- Only make adjustments within the recommended range.
- Ride slowly to start with after making adjustments to get the feel of the new handling characteristic.

- Set the adjusting screws to the position determined before removal.
- Mount protective cover (F).

## 6.12.9 Greasing the steering head bearing

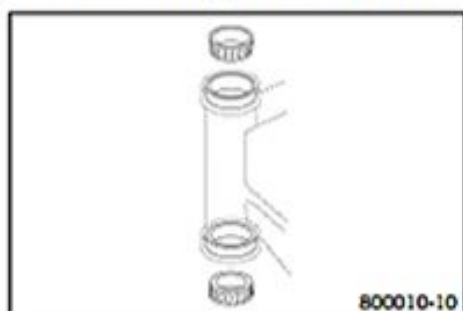

(EXC EU/AUS/US, XC-W)

- Remove the lower triple clamp. (☞ p. 36)
- Install the lower triple clamp. (☞ p. 37)

(EXC Factory Edition)

- Remove the lower triple clamp. (☞ p. 34)
- Install the lower triple clamp. (☞ p. 34)

## 6.12.10 Removing the lower triple clamp (EXC Factory Edition)

## Preparatory work

- Remove the headlight mask with the headlight. (☞ p. 103)
- Raise the motorcycle with the lift stand. (☞ p. 11)
- Remove the front wheel. (☞ p. 108)
- Remove the fork legs. (☞ p. 18)
- Remove the front fender. (☞ p. 103)
- Remove the handlebar cushion.

## Main work

- Open the cable holder in front of the right radiator and detach the wiring harness.
- Remove screws ① and hang the voltage regulator to the side.
- Remove screw ②. Remove screw ③. Take off the upper triple clamp with the handlebar and set it aside.



## Info

Protect the components against damage by covering them.  
Do not bend the cables and lines.



500651-10



500653-10

- Remove O-ring ④. Remove protective ring ⑤.
- Take off the lower triple clamp with the steering stem.
- Remove the upper steering head bearing.

## 6.12.11 Installing the lower triple clamp (EXC Factory Edition)

## Main work

- Clean the bearing and sealing elements, check for damage, and grease.

High viscosity grease (☞ p. 311)

- Insert the lower triple clamp with the steering stem. Mount the upper steering head bearing.
- Check whether the upper steering head seal ① is correctly positioned.
- Slide on protective ring ② and O-ring ③.

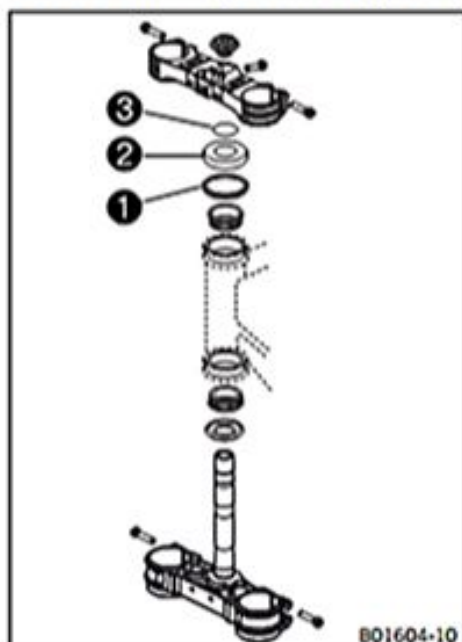

B01604-10



500652-10

- Position the upper triple clamp with the handlebar.
- Mount screw ④ but do not tighten yet.
- Position the clutch line, wiring harness, and voltage regulator. Mount and tighten screws ⑤.

## Guideline

Remaining screws, chassis	M6	10 Nm (7.4 lbf ft)
---------------------------	----	--------------------



- Position the fork legs.
  - ✓ Bleeder screws **6** are positioned toward the front.

**Info**

Grooves are milled into the side of the upper end of the fork legs. The second milled groove (from the top) must be flush with the top edge of the upper triple clamp.



- Tighten screws **7**.

## Guideline

Screw, bottom triple clamp	M8	15 Nm (11.1 lbf ft)
----------------------------	----	------------------------



- Tighten screw **4**.

## Guideline

Screw, top steering head	M20x1.5	12 Nm (8.9 lbf ft)
--------------------------	---------	--------------------



- Mount and tighten screw **8**.

## Guideline

Screw, top steering stem	M8	17 Nm (12.5 lbf ft)	Loctite® 243™
--------------------------	----	------------------------	---------------

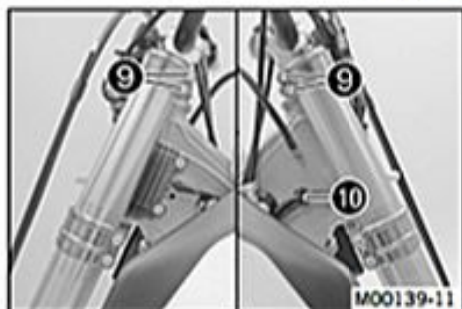

- Tighten screws **9**.

## Guideline

Screw, top triple clamp	M8	17 Nm (12.5 lbf ft)
-------------------------	----	------------------------

- Secure the wiring harness with cable holder **10**.

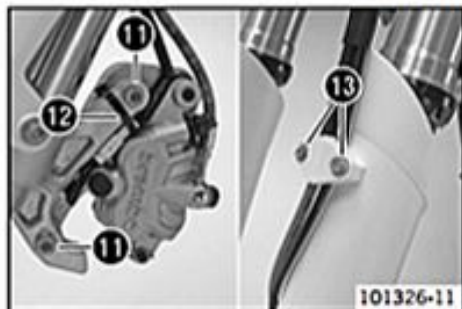

- Position the brake caliper. Mount and tighten screws **11**.

## Guideline

Screw, front brake caliper	M8	25 Nm (18.4 lbf ft)	Loctite® 243™
----------------------------	----	------------------------	---------------

- Mount cable binder **12**.

- Position the brake line, wiring harness, and clamp. Mount and tighten screws **13**.

**Finishing work**

- Mount the handlebar cushion.
- Install the front fender. (☛ p. 103)
- Install the front wheel. (☛ p. 108)
- Refit the headlight mask with the headlight. (☛ p. 104)
- Check that the wiring harness, throttle cables and brake and clutch lines can move freely and are routed correctly.
- Check the steering head bearing play. (☛ p. 39)
- Remove the motorcycle from the lift stand. (☛ p. 11)
- Check the headlight setting. (☛ p. 131)

**6.12.12 Removing the lower triple clamp (EXC EU/AUS/US, XC-W)****Preparatory work**

- Remove the headlight mask with the headlight. (☛ p. 103)
- Raise the motorcycle with the lift stand. (☛ p. 11)
- Remove the front wheel. (☛ p. 108)
- Remove the fork legs. (☛ p. 18)
- Remove the front fender. (☛ p. 103)
- Remove the handlebar cushion.

**Main work**

- Open the cable holder in front of the right radiator and detach the wiring harness.
- Remove screws ❶ and hang the voltage regulator to one side.
- Release screw ❷ and remove screw ❸. Take off the upper triple clamp with the handlebar and set it aside.

**Info**

Protect the components against damage by covering them.  
Do not bend the cables and lines.

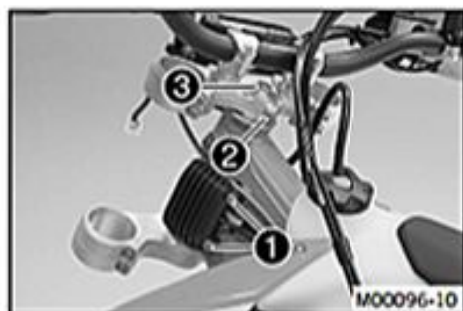

M00096-10

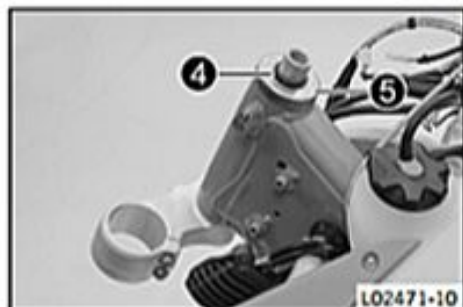

L02471-10

- Remove O-ring ❹. Remove protective ring ❺.
- Take off the lower triple clamp with the steering stem.
- Remove the upper steering head bearing.

## 6.12.13 Installing the lower triple clamp (EXC EU/AUS/US, XC-W)

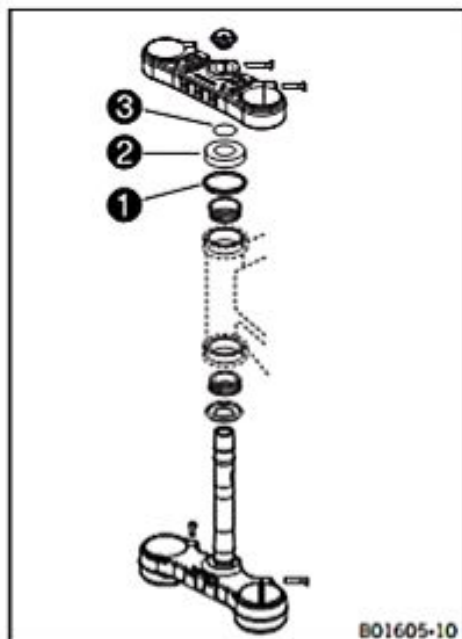

B01605-10

## Main work

- Clean the bearing and sealing elements, check for damage, and grease.

High viscosity grease (☞ p. 311)
----------------------------------

- Insert the lower triple clamp with the steering stem. Mount the upper steering head bearing.
- Check whether the upper steering head seal ① is correctly positioned.
- Slide on protective ring ② and O-ring ③.

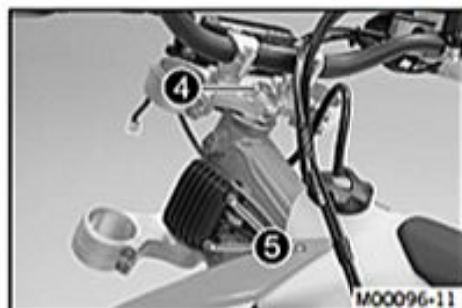

M00096-11

- Position the upper triple clamp with the handlebar.
- Mount screw ④ but do not tighten yet.
- Position the clutch line, wiring harness, and voltage regulator. Mount and tighten screws ⑤.

## Guideline

Remaining screws, chassis	M6	10 Nm (7.4 lbf ft)
---------------------------	----	--------------------

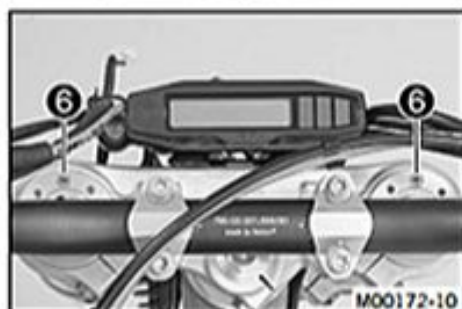

M00172-10

- Position the fork legs.
- ✓ Bleeder screws ⑥ are positioned toward the front.



## Info

Grooves are milled into the side of the upper end of the fork legs. The second milled groove (from the top) must be flush with the top edge of the upper triple clamp.

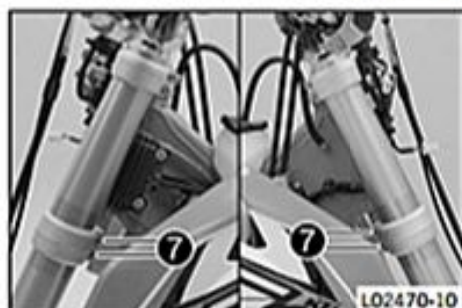

L02470-10

## (EXC EU, EXC AU, XC-W)

- Tighten screws ⑦.

## Guideline

Screw, bottom triple clamp	M8	15 Nm (11.1 lbf ft)
----------------------------	----	------------------------

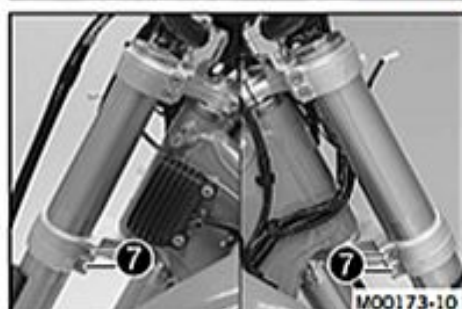

M00173-10

## (500 EXC US)

- Tighten screws ⑦.

## Guideline

Screw, bottom triple clamp	M8	15 Nm (11.1 lbf ft)
----------------------------	----	------------------------



- Tighten screw 4.

Guideline

Screw, top steering head	M20x1.5	12 Nm (8.9 lbf ft)
--------------------------	---------	--------------------

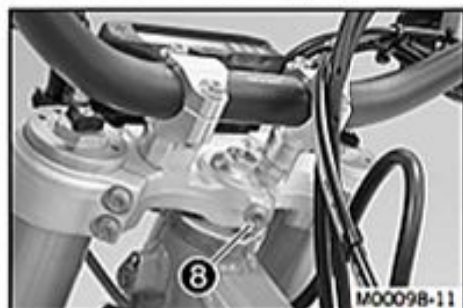

- Tighten screw 8.

Guideline

Screw, top steering stem	M8	20 Nm (14.8 lbf ft)
--------------------------	----	------------------------

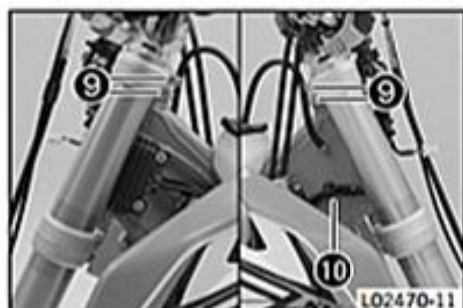

(EXC EU, EXC AU, XC-W)

- Tighten screws 9.

Guideline

Screw, top triple clamp	M8	20 Nm (14.8 lbf ft)
-------------------------	----	------------------------

- Secure the wiring harness with cable holder 10.

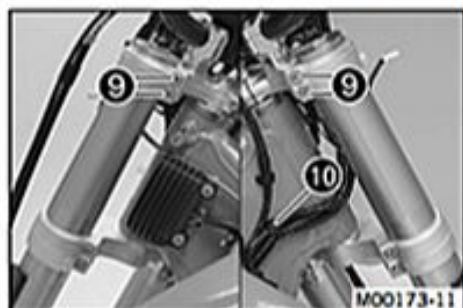

(500 EXC US)

- Tighten screws 9.

Guideline

Screw, top triple clamp	M8	20 Nm (14.8 lbf ft)
-------------------------	----	------------------------

- Secure the wiring harness with cable holder 10.

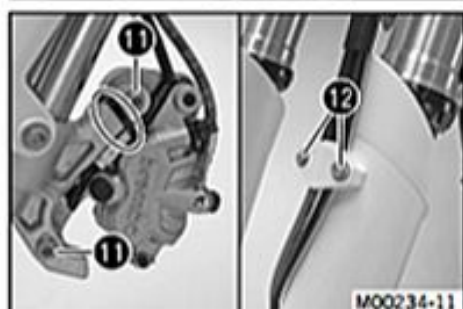

- Position the brake caliper. Mount and tighten screws 11.

Guideline

Screw, front brake caliper	M8	25 Nm (18.4 lbf ft)	Loctite® 243™
----------------------------	----	------------------------	---------------

- Mount cable binder.
- Position the brake line, wiring harness, and clamp. Mount and tighten screws 12.

#### Finishing work

- Mount the handlebar cushion.
- Install the front fender. (☛ p. 103)
- Install the front wheel. (☛ p. 108)
- Refit the headlight mask with the headlight. (☛ p. 104)
- Check that the wiring harness, throttle cables and brake and clutch lines can move freely and are routed correctly.
- Check the steering head bearing play. (☛ p. 39)
- Remove the motorcycle from the lift stand. (☛ p. 11)
- Check the headlight setting. (☛ p. 131)



## 6.12.14 Checking the steering head bearing play

- Warning**  
**Danger of accidents** Unstable vehicle handling from incorrect steering head bearing play.
- Adjust the steering head bearing play without delay.

- Info**  
 If the bike is ridden with play in the steering head bearing, the bearing and the bearing seats in the frame can become damaged over time.

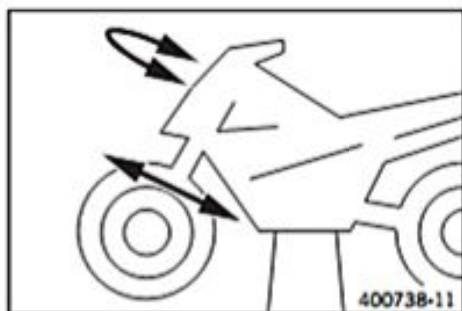

### Preparatory work

- Raise the motorcycle with the lift stand. (☞ p. 11)

### Main work

- Move the handlebar to the straight-ahead position. Move the fork legs to and fro in the direction of travel.

No play should be noticeable in the steering head bearing.

- If there is noticeable play present:  
**(EXC EU/AUS/US, XC-W)**
  - Adjust the play of the steering head bearing. (☞ p. 40)**(EXC Factory Edition)**
  - Adjust the play of the steering head bearing. (☞ p. 39)

- Move the handlebar to and fro over the entire steering range.

The handlebar must be able to move easily over the entire steering range. No resting locations should be noticeable.

- If click positions are noticeable:  
**(EXC EU/AUS/US, XC-W)**
  - Adjust the play of the steering head bearing. (☞ p. 40)**(EXC Factory Edition)**
  - Adjust the play of the steering head bearing. (☞ p. 39)
  - Check the steering head bearing and replace if required.

### Finishing work

- Remove the motorcycle from the lift stand. (☞ p. 11)

## 6.12.15 Adjusting the play of the steering head bearing (EXC Factory Edition)



### Preparatory work

- Raise the motorcycle with the lift stand. (☞ p. 11)

### Main work

- Release screws ①. Remove screw ②.
- Loosen and retighten screw ③.

#### Guideline

Screw, top steering head	M20x1.5	12 Nm (8.9 lbf ft)
--------------------------	---------	--------------------

- Using a plastic hammer, tap lightly on the upper triple clamp to avoid strains.
- Tighten screws ①.

#### Guideline

Screw, top triple clamp	M8	17 Nm (12.5 lbf ft)
-------------------------	----	---------------------

- Mount and tighten screw ②.

#### Guideline

Screw, top steering stem	M8	17 Nm (12.5 lbf ft)	Loctite® 243™
--------------------------	----	---------------------	---------------

### Finishing work

- Check the steering head bearing play. (☞ p. 39)
- Remove the motorcycle from the lift stand. (☞ p. 11)

## 6.12.16 Adjusting the play of the steering head bearing (EXC EU/AUS/US, XC-W)

## Preparatory work

- Raise the motorcycle with the lift stand. (☛ p. 11)

## Main work

(EXC EU, EXC AU, XC-W)

- Loosen screws ① and ②.
- Loosen and retighten screw ③.

## Guideline

Screw, top steering head	M20x1.5	12 Nm (8.9 lbf ft)
--------------------------	---------	-----------------------

- Using a plastic hammer, tap lightly on the upper triple clamp to avoid strains.
- Tighten screws ①.

## Guideline

Screw, top triple clamp	M8	20 Nm (14.8 lbf ft)
-------------------------	----	------------------------

- Tighten screw ②.

## Guideline

Screw, top steering stem	M8	20 Nm (14.8 lbf ft)
--------------------------	----	------------------------

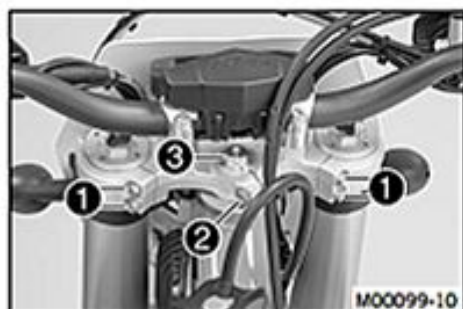

M00099-10



M00174-10

(500 EXC US)

- Loosen screws ① and ②.
- Loosen and retighten screw ③.

## Guideline

Screw, top steering head	M20x1.5	12 Nm (8.9 lbf ft)
--------------------------	---------	-----------------------

- Using a plastic hammer, tap lightly on the upper triple clamp to avoid strains.
- Tighten screws ①.

## Guideline

Screw, top triple clamp	M8	20 Nm (14.8 lbf ft)
-------------------------	----	------------------------

- Tighten screw ②.

## Guideline

Screw, top steering stem	M8	20 Nm (14.8 lbf ft)
--------------------------	----	------------------------

## Finishing work

- Check the steering head bearing play. (☛ p. 39)
- Remove the motorcycle from the lift stand. (☛ p. 11)

## 6.13 EXC Six Days

## 6.13.1 Performing a fork service

## Condition

The fork legs have been removed.

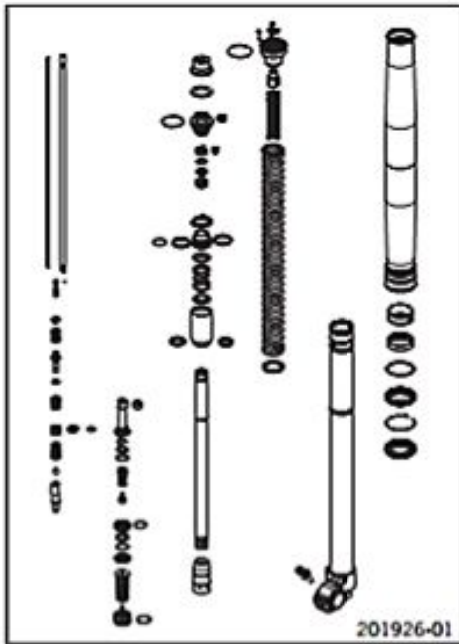

- Disassemble the fork legs. (☛ p. 41)
- Remove the spring. (☛ p. 43)
- Disassemble the cartridge. (☛ p. 44)
- Disassemble the piston rod. (☛ p. 45)
- Disassemble the hydrostop unit. (☛ p. 46)
- Disassemble the seal ring retainer. (☛ p. 46)
- Check the fork legs. (☛ p. 47)
- Assemble the seal ring retainer. (☛ p. 48)
- Assemble the hydrostop unit. (☛ p. 48)
- Assemble the piston rod. (☛ p. 49)
- Assemble the cartridge. (☛ p. 50)
- Assemble the fork legs. (☛ p. 51)

## 6.13.2 Disassembling the fork legs

**i** Info  
The steps are identical for both fork legs.

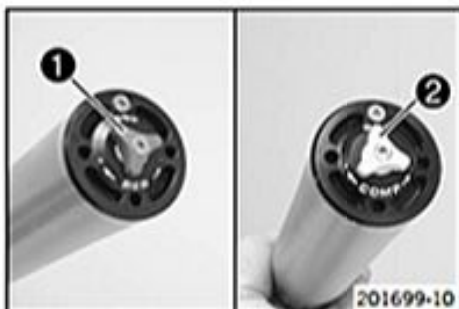

- Condition**  
The fork legs are disassembled.
- Note down the current state of rebound damping **1** REB (red adjuster of right fork leg).
  - Note down the current state of compression damping **2** COMP (white adjuster of left fork leg).
  - Fully open the adjusters of the rebound and compression damping.



- Clamp the fork leg in the area of the lower triple clamp.

Clamping stand (T1403S) (☛ p. 325)

- Remove the screw. Remove adjuster **3**.



- Release screw cap **4**.

Special socket (T14047) (☛ p. 325)

**i** Info  
The cartridge cannot be taken off yet.



- Unclamp the fork leg.
- Push the outer tube down. Drain the fork oil.

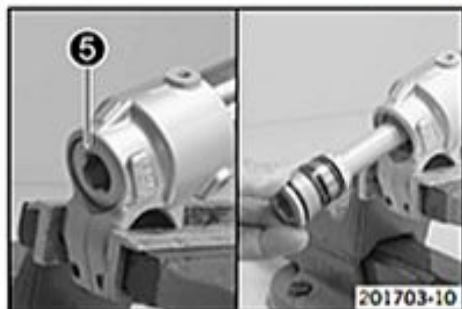

- Clamp the fork leg with the axle clamp.
- Release hydrostop unit **5** and remove it.

**i Info**  
Do not use an impact wrench.  
Place a pan underneath since oil will run out.

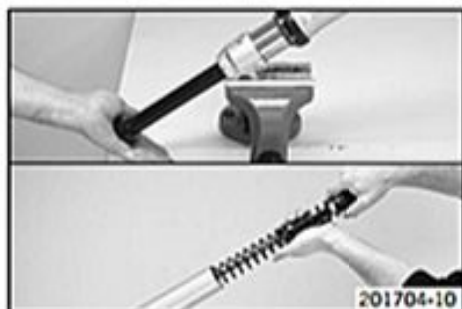

- Remove the cartridge from the fork leg.

Press-out tool (T14051) (☞ p. 326)

**i Info**  
Removing the O-ring seat from the cartridge usually requires the application of force.

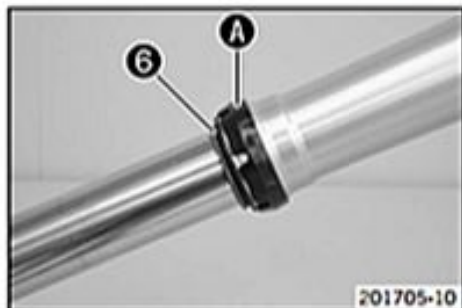

- Remove dust boot **6**.
- Remove fork protection ring **A**.

**i Info**  
The fork protection ring does not necessarily need to be removed for repair work.



- Remove lock ring **7**.

**i Info**  
The lock ring has a ground end against which a screwdriver can be positioned.

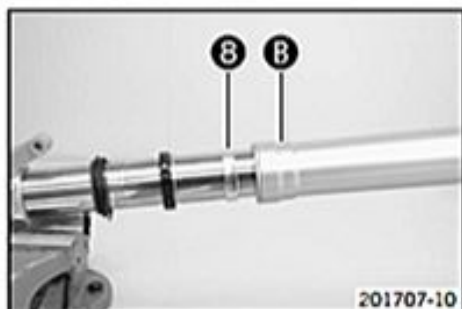

- Warm the outer tube in area **B** of the lower sliding bushing.

Guideline  
50 °C (122 °F)

- Pull the outer tube forcefully off of the inner tube.

**i Info**  
The lower sliding bushing **8** must be pulled out of its bearing seat.



- Remove the upper sliding bushing 9.



**Info**

Do not use a tool; pull the ends apart slightly by hand.



- Take off the lower sliding bushing 8.
- Take off support ring 10.
- Take off seal ring 11.
- Take off lock ring 7.
- Take off dust boot 6.
- Unclamp the fork leg.

### 6.13.3 Removing the spring



**Info**

The steps are identical for both fork legs.

**Preparatory work**

- Disassemble the fork legs. (☛ p. 41)

**Main work**

- Pull the spring down. Mount the open end wrench on the hexagonal part.

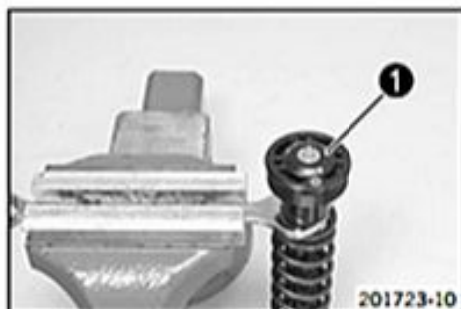

- Clamp the open end wrench in the vise. Release screw cap 1 but do not remove it yet.

Special socket (T14047) (☛ p. 325)



- Pull the spring down. Remove the open end wrench.
- Remove the screw cap.
- Remove the spring with the preload spacer(s).

## 6.13.4 Disassembling the cartridge



## Info

The steps are identical for both fork legs.

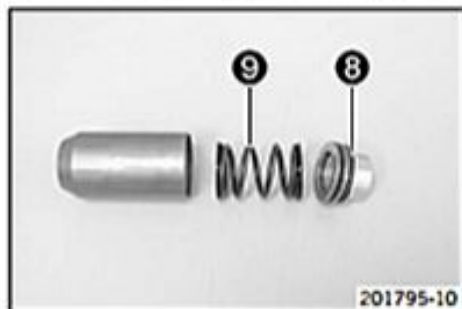
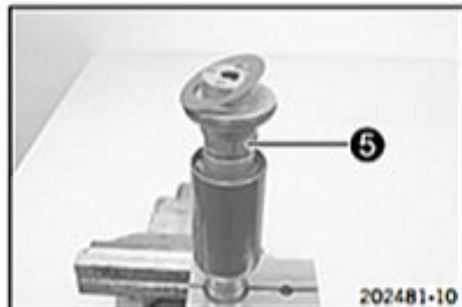
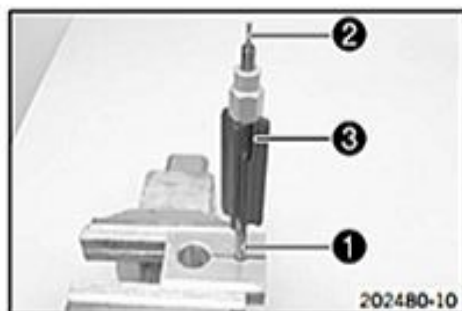

## Preparatory work

- Disassemble the fork legs. (☞ p. 41)
- Remove the spring. (☞ p. 43)

## Main work

- Degrease piston rod ① and clamp it in the vise.

Clamping stand (T14049S) (☞ p. 326)

- Remove adjusting tube ②. Unscrew spring guide ③.

- Remove spring seat ④.
- Pull the piston rod out of the cartridge.

- Clamp the tube of the cartridge into a vise.

Clamping stand (T14049S) (☞ p. 326)

- Release seal ring retainer ⑤ and remove with the washer.

- Remove lock ring ⑥.
- Pull reservoir ⑦ off of the tube.

- Pull sleeve ⑧ out of the reservoir.
- Remove spring ⑨.

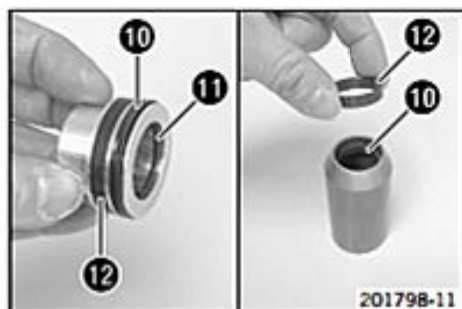

- Remove seal rings 10 and O-ring 11.
- Remove pilot bushings 12.

### 6.13.5 Disassembling the piston rod



#### Info

The steps are identical for both fork legs, except for the hydrostop needle and valve.

#### Preparatory work

- Disassemble the fork legs. (☛ p. 41)
- Remove the spring. (☛ p. 43)
- Disassemble the cartridge. (☛ p. 44)

#### Main work

- Degrease the piston rod.
- Clamp the piston rod with the special tool as far up as possible.

Clamping stand (T14049S) (☛ p. 326)

- Release hydrostop needle 1 and remove it from the piston rod.
- ✓ The valve 2 usually remains in the hydrostop needle.

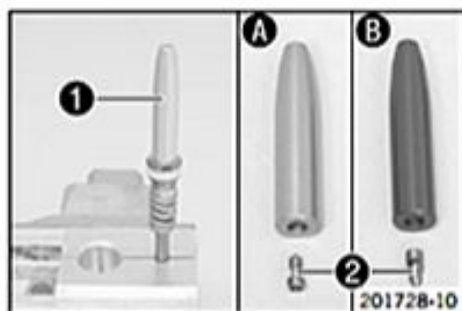

#### Info

- A - silver hydrostop needle on compression damping side.
- B - red hydrostop needle on rebound damping side.

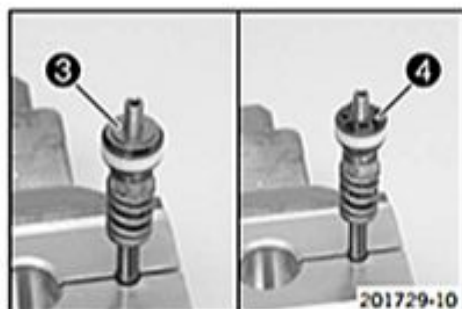

- Remove the rebound shim stack 3.
- Remove piston 4.

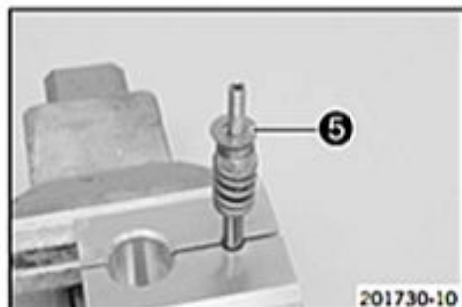

- Remove the compression shim stack 5.
- Remove spring.

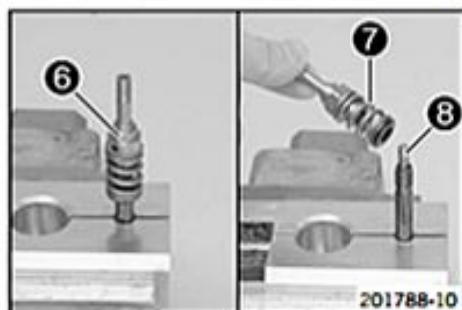

- Remove adapter 6 with spring 7 and washer.
- Remove spring 8.

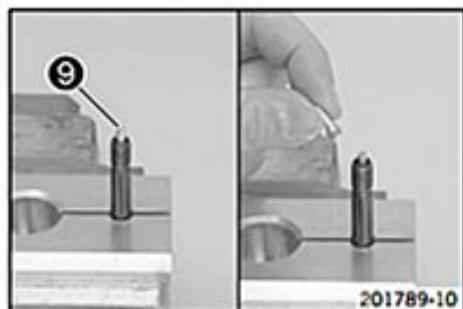

- Remove valve needle 9 from the piston rod.

**Info**

The adjusting tube can be used for this.

### 6.13.6 Disassembling the hydrostop unit

**Info**

The steps are identical for both fork legs.

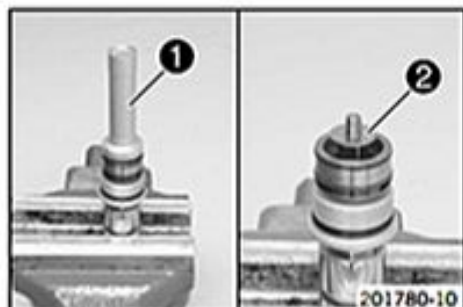
**Preparatory work**

- Disassemble the fork legs. (☛ p. 41)

**Main work**

- Mount the hydrostop unit on a fitting hexagon socket and clamp into a vice.
- Remove sleeve 1.
- Remove shim stack 2.

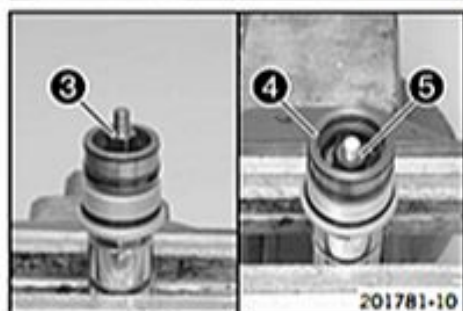

- Remove adapter 3.
- Remove hub 4 with washers 5.

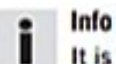
**Info**

It is possible that only one washer or no washer is present.

- Remove the O-ring from the hub.

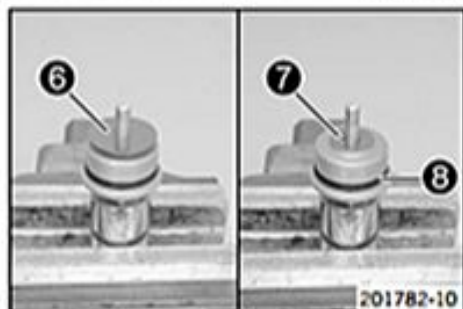

- Remove shim stack 6.
- Remove washer 7.
- Remove O-ring 8.

### 6.13.7 Disassembling the seal ring retainer

**Info**

The steps are identical for both fork legs.

**Preparatory work**

- Disassemble the fork legs. (☛ p. 41)
- Remove the spring. (☛ p. 43)
- Disassemble the cartridge. (☛ p. 44)



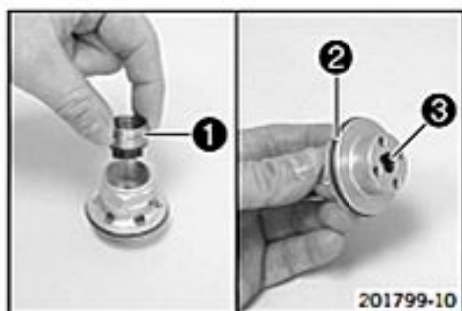

**Main work**

- Remove pilot bushing support ①.
- Remove O-ring ② and seal ring ③.

### 6.13.8 Checking the fork legs

**Condition**

The fork legs have been disassembled.



- Check the inner tube and axle clamp for damage.
  - If there is damage:
    - Change the inner tube.

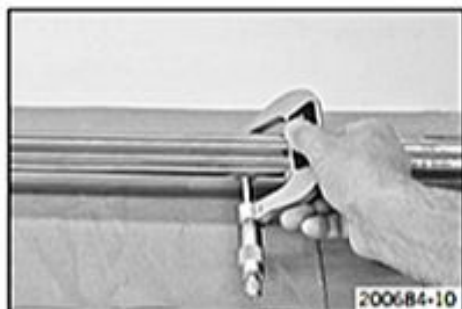

- Measure the outside diameter at multiple locations of the inner tube.

Outside diameter of inner tube	47.975... 48.005 mm (1.88878... 1.88996 in)
--------------------------------	---

- If the measured value is smaller than the specified value:
  - Change the inner tube.

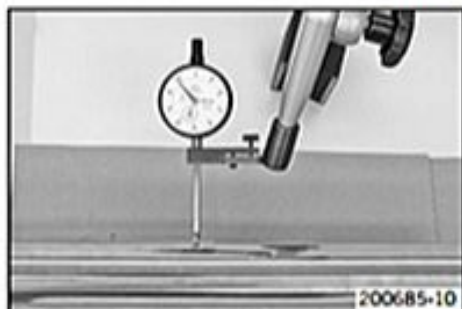

- Measure the run-out of the inner tube.

Inner tube run-out	≤ 0.20 mm (≤ 0.0079 in)
--------------------	-------------------------

- If the measured value is larger than the specified value:
  - Change the inner tube.

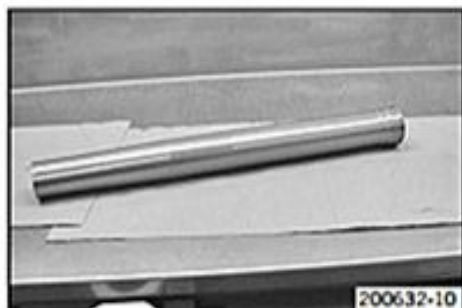

- Measure the inside diameter at multiple locations of the outer tube.

Inside diameter of outer tube	≤ 49.20 mm (≤ 1.937 in)
-------------------------------	-------------------------

- If the measured value is larger than the specified value:
  - Change the outer tube.
- Check the outer tube for damage.
  - If there is damage:
    - Change the outer tube.



- Check the surface of the sliding bushings.
  - If the bronze-colored layer **A** under sliding layer **B** is visible or the surface is rough:
    - Change the sliding bushings.

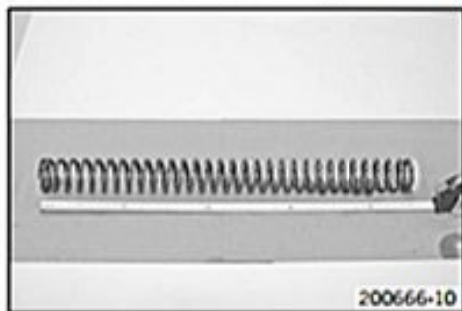

- Check the spring length.

**Guideline**

Spring length with preload spacer(s)	472 mm (18.58 in)
--------------------------------------	-------------------

- If the measured value is larger than the specified value:
  - Reduce the thickness of the preload spacers.
- If the measured value is smaller than the specified value:
  - Increase the thickness of the preload spacers.

### 6.13.9 Assembling the seal ring retainer



**Info**

The steps are identical for both fork legs.

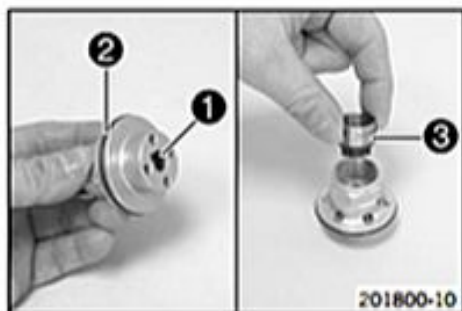

- Mount and grease seal ring **1**.

Lubricant (T158) (☛ p. 311)
-----------------------------

- Mount and grease O-ring **2**.

Lubricant (T158) (☛ p. 311)
-----------------------------

- Position pilot bushing support **3**.

### 6.13.10 Assembling the hydrostop unit



**Info**

The steps are identical for both fork legs.

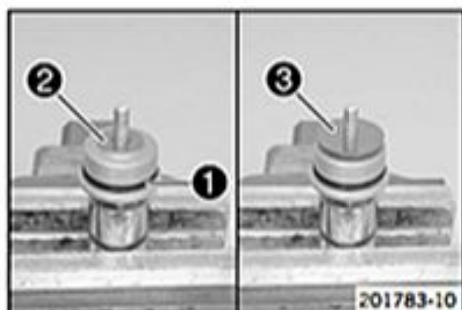

- Mount and grease O-ring **1**.

Lubricant (T158) (☛ p. 311)
-----------------------------

- Mount washer **2**.

- Mount shim stack **3** with the smaller washers facing downward.

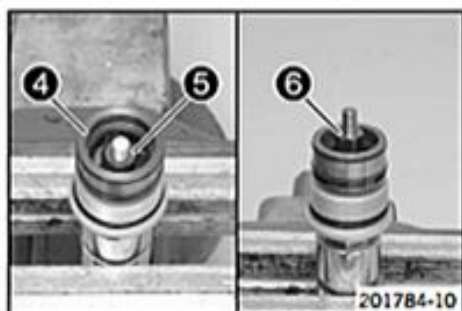

- Mount the new O-ring on hub **4**.

- Mount the hub with washers **5**.



**Info**

It is possible that only one or no washer is present.

- Mount and tighten adapter **6**.

**Guideline**

Hydrostop unit adapter	M6x0.5	7 Nm (5.2 lbf ft)
------------------------	--------	-------------------

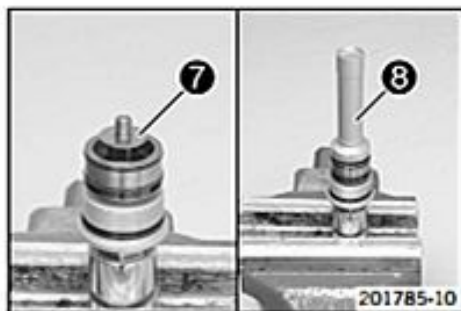

- Mount shim stack **7** with the smaller washers facing downward.
- Mount and tighten sleeve **8**.

Guideline

Hydrostop unit sleeve	M6x0.5	7 Nm (5.2 lbf ft)
-----------------------	--------	-------------------

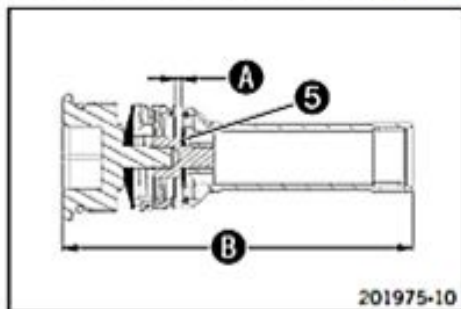

- Check distance **A** and total length **B** of the hydrostop.

Guideline

Hydrostop distance	$\geq 1.5 \text{ mm}$ ( $\geq 0.059 \text{ in}$ )
Hydrostop length	108.5... 109.5 mm (4.272... 4.311 in)

- If the dimensions are out of tolerance:
  - Add or remove washers **5**.

## 6.13.11 Assembling the piston rod



### Info

The steps are identical for both fork legs, except for the hydrostop needle and valve.

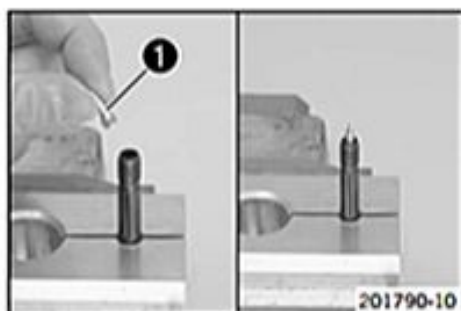

- Degrease the piston rod.
- Clamp the piston rod with the special tool.

Clamping stand (T14049S) (☞ p. 326)

- Lubricate the O-ring. Mount valve needle **1** in the piston rod.

Lubricant (T158) (☞ p. 311)

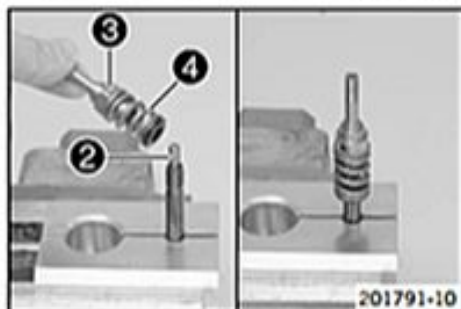

- Mount spring **2**.
- Mount and tighten adapter **3** with spring **4** and washer.

Guideline

Adapter of piston rod	M6x0.5	12 Nm (8.9 lbf ft)
-----------------------	--------	--------------------

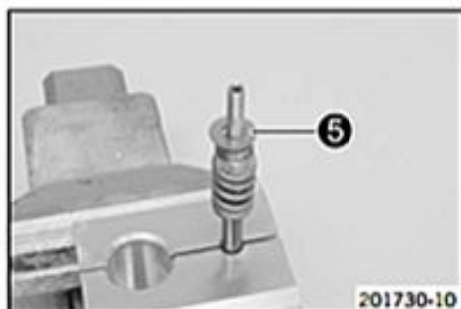

- Position the spring.
- Mount the compression shim stack **5** with the smaller washers facing downward.

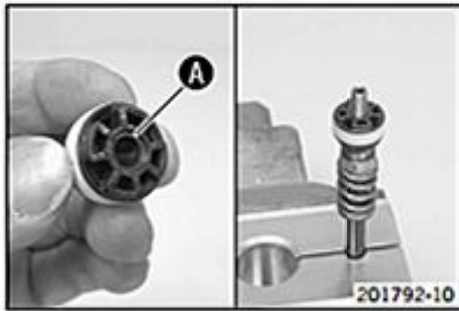

- Grind the piston on both sides on a surfacing plate using 1200 grit sandpaper.
- Clean the piston.
- Lubricate the piston ring.

Fork oil (SAE 4) (48601166S1) (☛ p. 310)

- Mount the piston with chamfer **A** facing down.

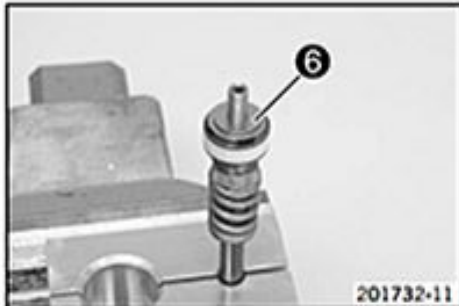

- Mount the rebound shim stack **6** with the smaller washers facing upward.

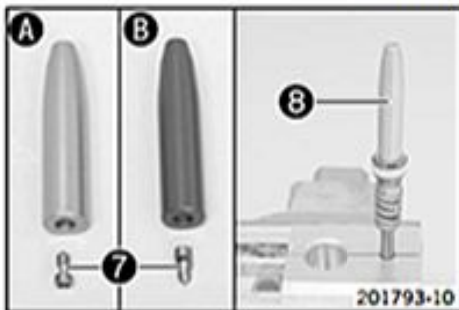

- Press the piston downward against the spring.  
✓ The piston should not squeeze the shims.
- Position valve **7** in the hydrostop needle **8**. Mount and tighten the hydrostop needle.

**Guideline**

Hydrostop needle on piston rod	M6x0.5	7 Nm (5.2 lbf ft)
--------------------------------	--------	-------------------



**Info**

- A** – silver hydrostop needle on compression damping side.
- B** – red hydrostop needle on rebound damping side.

- Unclamp the piston rod.

### 6.13.12 Assembling the cartridge



**Info**

The steps are identical for both fork legs.

**Preparatory work**

- Assemble the seal ring retainer. (☛ p. 48)
- Assemble the piston rod. (☛ p. 49)

**Main work**

- Mount and grease seal rings **1** and O-ring **2**.

Lubricant (T158) (☛ p. 311)

- Mount and lubricate pilot bushings **3**.

Fork oil (SAE 4) (48601166S1) (☛ p. 310)

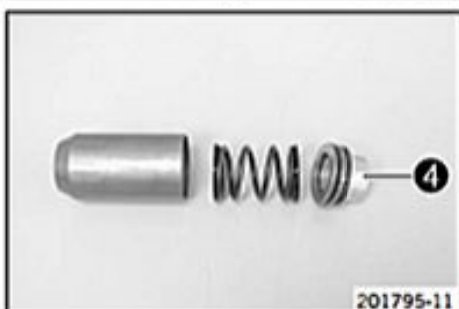
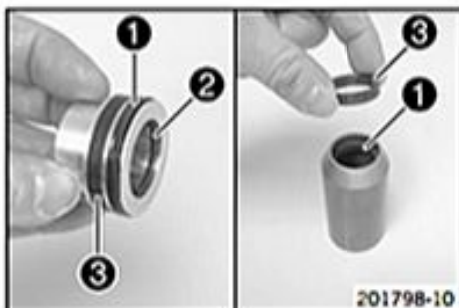

- Check the length of the reservoir spring.

**Guideline**

Reservoir spring length with preload spacer	46 mm (1.81 in)
---	-----------------

- If the length is out of tolerance:
  - Correct the preload spacers.
- Position the spring with the preload spacers in the reservoir.

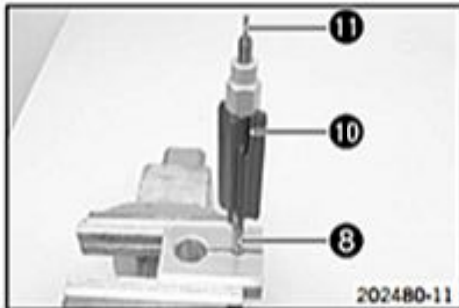
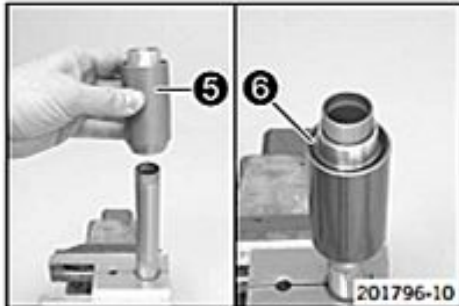

- Position sleeve 4 in the reservoir.
- Clamp the tube of the cartridge into a vise.

Clamping stand (T14049S) (☛ p. 326)

- Slide reservoir 5 onto the tube.

**i Info**  
Hold the sleeve in the reservoir to prevent it from sliding out.

- Mount lock ring 6.
- Mount seal ring retainer 7 with the washer and tighten.

Guideline

Seal ring retainer	M23.5x0.75	46 Nm (33.9 lbf ft)	Loctite® 2701™
--------------------	------------	------------------------	----------------

- Unclamp the cartridge.

- Slide piston rod 8 into the cartridge.

**i Info**  
Ensure that the piston ring is seated correctly.

- Mount spring seat 9.

- Degrease piston rod 8 and clamp in the vise.

Clamping stand (T14049S) (☛ p. 326)

- Screw spring guide 10 all the way on.

**i Info**  
The nut must be firmly tightened against the stop by hand. Do not use a tool.

- Mount adjusting tube 11.
- Unclamp the piston rod. Mount the preload spacer(s).

### 6.13.13 Assembling the fork legs

**i Info**  
When assembling, ensure that the right cartridge is mounted in the corresponding inner tube and the right adjuster is mounted on the corresponding screw cap.  
Compression damping side – screw cap with mark **COMP**, brake caliper holder, white adjuster.  
Rebound damping side – screw cap with mark **REB**, no brake caliper holder, red adjuster.



- Preparatory work**
- Assemble the hydrostop unit. (☛ p. 48)

- Main work**
- Clamp the inner tube with the axle clamp.

Guideline  
Use soft jaws.

- Mount special tool.

Protecting sleeve (T1401) (☛ p. 324)

- Lubricate and mount dust boot ❶.

Lubricant (T511) (☞ p. 311)

**i Info**  
Always change the dust boot, seal ring, lock ring and support ring.  
Mount the sealing lip with the spring expander facing downward.

- Slide on lock ring ❷.
- Lubricate and slide on seal ring ❸.

Lubricant (T511) (☞ p. 311)

**i Info**  
Mount with the sealing lip facing down and the open side facing up.

- Slide on support ring ❹.
- Remove the special tool.
- Grind the edges of the sliding bushings with sandpaper grit 600, clean the bushings and lubricate them.

Fork oil (SAE 4) (48601166S1) (☞ p. 310)



- Slide on the lower sliding bushing ❺.
- Mount the upper sliding bushing ❻.

**i Info**  
Do not use a tool; pull the ends apart slightly by hand.



- Warm the outer tube in area A of the lower sliding bushing.  
Guideline

50 °C (122 °F)

- Slide the outer tube onto the inner tube.
- Hold the lower sliding bushing with the longer section of the special tool.

Mounting tool (T14040S) (☞ p. 325)

- Push the sliding bushing all the way into the outer tube.



- Position the support ring.
- Hold the seal ring with the shorter section of the special tool.

Mounting tool (T14040S) (☞ p. 325)

- Push the seal ring and support ring all the way into the outer tube.

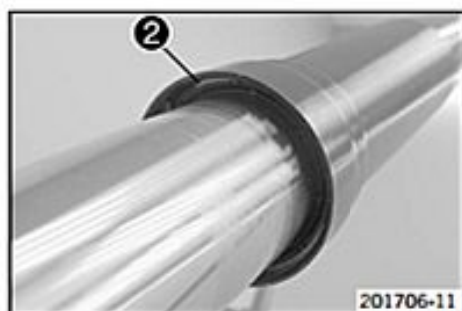

- Mount lock ring ②.

**Info**

The lock ring must engage audibly.

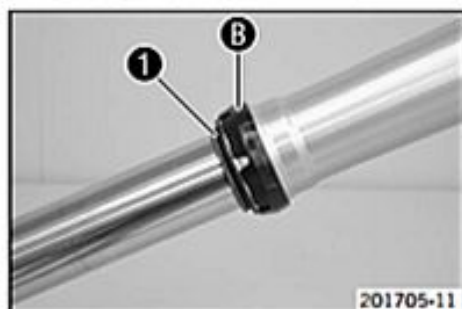

- Mount dust boot ①.
- Mount fork protection ring B.



- Lubricate the O-ring. Slide the cartridge all the way into the fork leg.

Fork oil (SAE 4) (48601166S1) (☛ p. 310)
--



- Turn the fork. Have the entire filling quantity of fork oil available.

Oil capacity per fork leg	635 ml (21.47 fl. oz.)	Fork oil (SAE 4) (48601166S1) (☛ p. 310)
---------------------------	------------------------	--

- Add some of the fork oil while pulling out and pushing in the piston rod numerous times.

**Guideline**

Fork oil quantity	510 ml (17.24 fl. oz.)
-------------------	------------------------

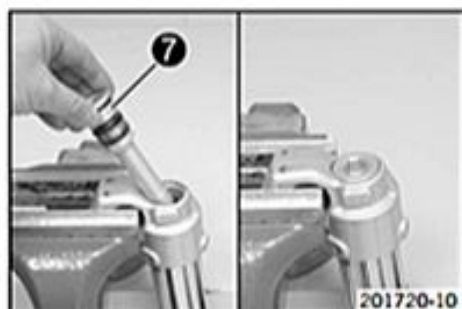

- Mount and tighten hydrostop unit ⑦.

**Guideline**

Hydrostop unit	M30x1	40 Nm (29.5 lbf ft)
----------------	-------	---------------------



- Clamp the fork vertically.
- Add the remaining quantity of fork oil.

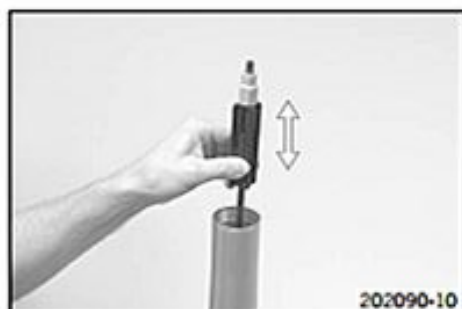

- Pull out the piston rod and push it back in numerous times while pressing it to one side slightly.
  - ✓ Air bubbles emerge and the cartridge is bled.
- Keep bleeding until no more air bubbles emerge.
  - ✓ The piston rod moves out automatically to the middle of the total stroke distance.

**Info**

When fully bled, the correct air chamber length is achieved automatically.

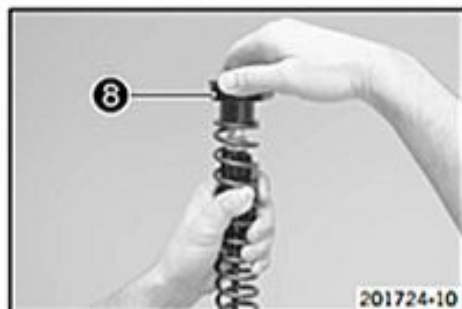

- Position spring.
- Pull the spring down. Mount screw cap **8**.

**Info**

When assembling, ensure that the screw caps are correctly mounted according to the hydrostop needles.

Rebound damping side – red hydrostop needle, screw cap with mark **REB**.  
 Compression damping side – silver hydrostop needle, screw cap with mark **COMP**.



- Pull the spring down. Mount the open end wrench on the hexagonal part.
- Hold the open end wrench. Tighten screw cap **8**.

**Guideline**

Screw cap on piston rod	M8x0.75	18 Nm (13.3 lbf ft)
-------------------------	---------	------------------------

Special socket (T14047) (☛ p. 325)



- Push the outer tube up.
- Clamp the outer tube in the area of the lower triple clamp.

Clamping stand (T1403S) (☛ p. 325)

- Tighten screw cap **8**.

**Guideline**

Cartridge on outer tube	M51x1.5	40 Nm (29.5 lbf ft)
-------------------------	---------	------------------------

Special socket (T14047) (☛ p. 325)



- Mount the adjuster. Mount and tighten screw **9**.

**Guideline**

Screw, adjuster	M4x0.5	2.5 Nm (1.84 lbf ft)
-----------------	--------	-------------------------

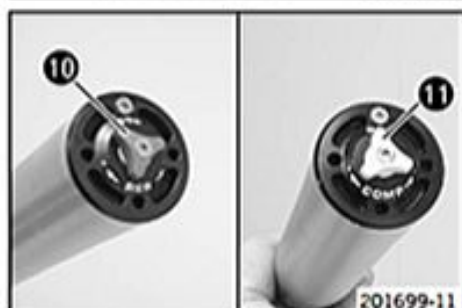
**Alternative 1**

- Turn the adjuster of compression damping **10** (mark **COMP**) and the adjuster of rebound damping **11** (mark **REB**) all the way clockwise.



## Guideline

Rebound damping	
Comfort	15 clicks
Standard	13 clicks
Sport	11 clicks
Compression damping	
Comfort	15 clicks
Standard	13 clicks
Sport	11 clicks

- Turn counterclockwise by the number of clicks corresponding to the fork type.

## Alternative 2

**Warning**

**Danger of accident** Modifications to the suspension setting may seriously alter the handling characteristic.

Extreme modifications to the suspension setting may cause a serious deterioration in the handling characteristic and overload components.

- Only make adjustments within the recommended range.
  - Ride slowly to start with after making adjustments to get the feel of the new handling characteristic.
- 
- Set the adjusters to the positions determined upon removal.

## 6.13.14 Greasing the steering head bearing

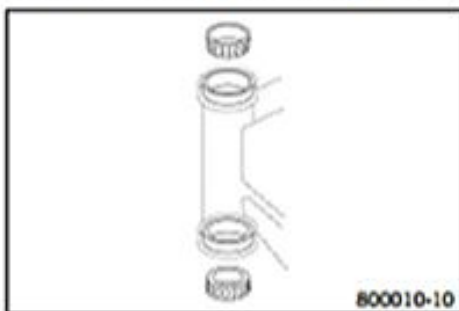

- Remove the lower triple clamp. (☛ p. 55)
- Install the lower triple clamp. (☛ p. 56)

## 6.13.15 Removing the lower triple clamp

**Preparatory work**

- Remove the headlight mask with the headlight. (☛ p. 103)
- Raise the motorcycle with the lift stand. (☛ p. 11)
- Remove the front wheel. (☛ p. 108)
- Remove the fork legs. (☛ p. 18)
- Remove the front fender. (☛ p. 103)
- Remove the handlebar cushion.

**Main work**

- Open the cable holder in front of the right radiator and detach the wiring harness.
- Remove screws ① and hang the voltage regulator to the side.
- Remove screw ②. Remove screw ③. Take off the upper triple clamp with the handlebar and set it aside.

**Info**

Protect the components against damage by covering them.  
Do not bend the cables and lines.





- Remove O-ring (4). Remove protective ring (5).
- Take off the lower triple clamp with the steering stem.
- Remove the upper steering head bearing.

## 6.13.16 Installing the lower triple clamp

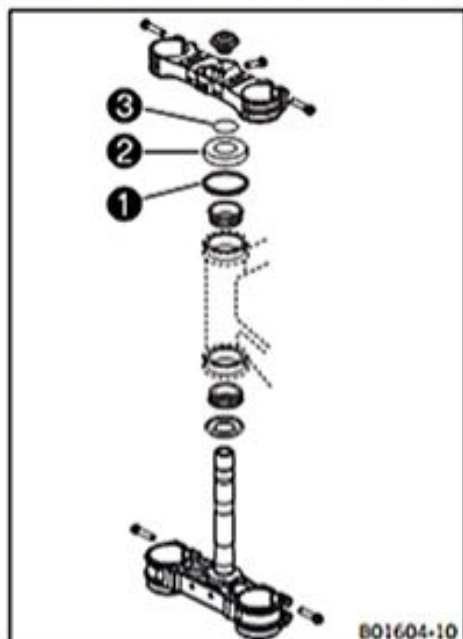

### Main work

- Clean the bearing and sealing elements, check for damage, and grease.

High viscosity grease (☛ p. 311)

- Insert the lower triple clamp with the steering stem. Mount the upper steering head bearing.
- Check whether the upper steering head seal (1) is correctly positioned.
- Slide on protective ring (2) and O-ring (3).

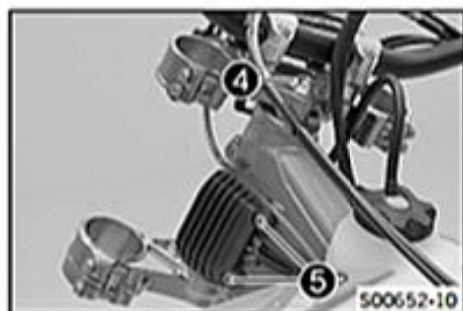

- Position the upper triple clamp with the handlebar.
- Mount screw (4) but do not tighten yet.
- Position the clutch line, wiring harness, and voltage regulator. Mount and tighten screws (5).

### Guideline

Remaining screws, chassis	M6	10 Nm (7.4 lbf ft)
---------------------------	----	--------------------



- Position the fork legs.
- ✓ Bleeder screws (6) are positioned toward the front.

### Info

The rebound damping is located in the right fork leg **REB** (red adjusting screw). The compression damping is located in the left fork leg **COMP** (white adjusting screw). Grooves are milled into the side of the upper end of the fork legs. The second milled groove (from the top) must be flush with the top edge of the upper triple clamp.

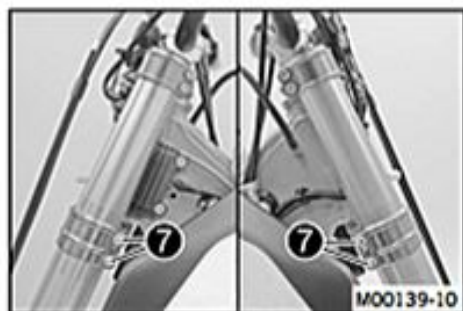

- Tighten screws (7).

### Guideline

Screw, bottom triple clamp	M8	15 Nm (11.1 lbf ft)
----------------------------	----	------------------------



- Tighten screw 4.

## Guideline

Screw, top steering head	M20x1.5	12 Nm (8.9 lbf ft)
--------------------------	---------	--------------------



- Mount and tighten screw 8.

## Guideline

Screw, top steering stem	M8	17 Nm (12.5 lbf ft)	Loctite® 243™
--------------------------	----	------------------------	---------------

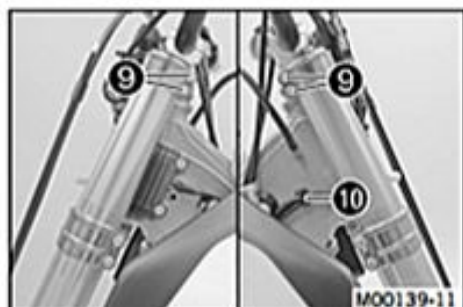

- Tighten screws 9.

## Guideline

Screw, top triple clamp	M8	17 Nm (12.5 lbf ft)
-------------------------	----	------------------------

- Secure the wiring harness with cable holder 10.

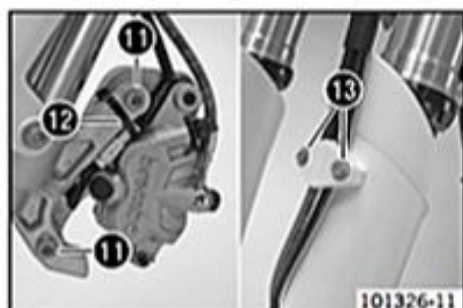

- Position the brake caliper. Mount and tighten screws 11.

## Guideline

Screw, front brake caliper	M8	25 Nm (18.4 lbf ft)	Loctite® 243™
----------------------------	----	------------------------	---------------

- Mount cable binder 12.
- Position the brake line, wiring harness, and clamp. Mount and tighten screws 13.

## Finishing work

- Mount the handlebar cushion.
- Install the front fender. (☛ p. 103)
- Install the front wheel. (☛ p. 108)
- Refit the headlight mask with the headlight. (☛ p. 104)
- Check that the wiring harness, throttle cables and brake and clutch lines can move freely and are routed correctly.
- Check the steering head bearing play. (☛ p. 57)
- Remove the motorcycle from the lift stand. (☛ p. 11)
- Check the headlight setting. (☛ p. 131)

## 6.13.17 Checking the steering head bearing play



## Warning

**Danger of accidents** Unstable vehicle handling from incorrect steering head bearing play.

- Adjust the steering head bearing play without delay.



## Info

If the bike is ridden with play in the steering head bearing, the bearing and the bearing seats in the frame can become damaged over time.

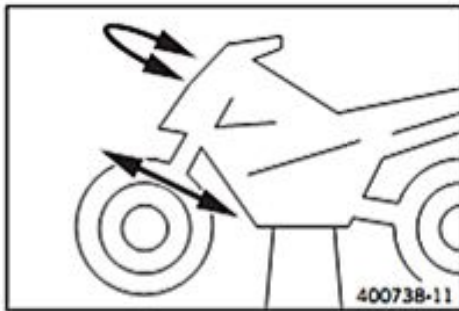

**Preparatory work**

- Raise the motorcycle with the lift stand. (☛ p. 11)

**Main work**

- Move the handlebar to the straight-ahead position. Move the fork legs to and fro in the direction of travel.

No play should be noticeable in the steering head bearing.

- If there is noticeable play present:
  - Adjust the play of the steering head bearing. (☛ p. 58)
- Move the handlebar to and fro over the entire steering range.

The handlebar must be able to move easily over the entire steering range. No resting locations should be noticeable.

- If click positions are noticeable:
  - Adjust the play of the steering head bearing. (☛ p. 58)
  - Check the steering head bearing and replace if required.

**Finishing work**

- Remove the motorcycle from the lift stand. (☛ p. 11)

### 6.13.18 Adjusting the play of the steering head bearing

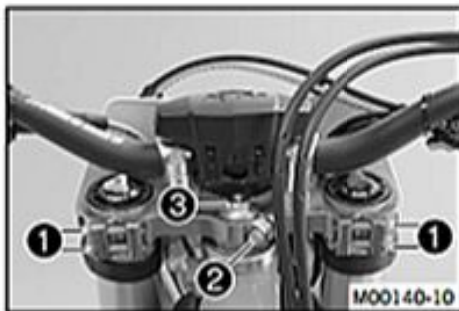

**Preparatory work**

- Raise the motorcycle with the lift stand. (☛ p. 11)

**Main work**

- Release screws ①. Remove screw ②.
- Loosen and retighten screw ③.

**Guideline**

Screw, top steering head	M20x1.5	12 Nm (8.9 lbf ft)
--------------------------	---------	--------------------

- Using a plastic hammer, tap lightly on the upper triple clamp to avoid strains.
- Tighten screws ①.

**Guideline**

Screw, top triple clamp	M8	17 Nm (12.5 lbf ft)
-------------------------	----	---------------------

- Mount and tighten screw ②.

**Guideline**

Screw, top steering stem	M8	17 Nm (12.5 lbf ft)	Loctite® 243™
--------------------------	----	---------------------	---------------

**Finishing work**

- Check the steering head bearing play. (☛ p. 57)
- Remove the motorcycle from the lift stand. (☛ p. 11)

## 7.1 Handlebar position

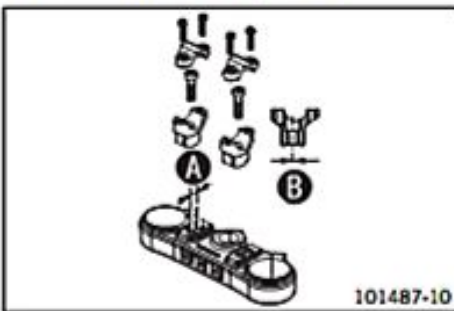

On the upper triple clamp, there are two holes at a distance of **A** to each other.

Hole distance <b>A</b>	15 mm (0.59 in)
------------------------	-----------------

The holes on the handlebar supports are placed at a distance of **B** from the center.

Hole distance <b>B</b>	3.5 mm (0.138 in)
------------------------	-------------------

The handlebar supports can be mounted in four different positions.

## 7.2 Adjusting handlebar position

**Warning**  
**Danger of accidents** Handlebar breakage.

- If the handlebar is bent or straightened it will cause material fatigue, and the handlebar can break. Always replace handlebar.

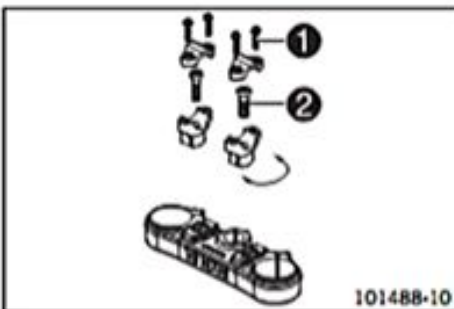

- Remove screws **1**. Take off the handlebar clamps. Remove the handlebar and lay it to one side.

**Info**  
 Cover the components to protect them against damage.  
 Do not bend the cables and lines.

- Remove screws **2**. Take off the handlebar supports.
- Place the handlebar supports in the required position. Mount and tighten screws **2**.

Guideline

Screw, handlebar holder	M10	40 Nm (29.5 lbf ft)	Loctite® 243™
-------------------------	-----	------------------------	---------------

**Info**  
 Position the left and right handlebar supports evenly.

- Position the handlebar.

**Info**  
 Make sure the cables and wiring are positioned correctly.

- Position the handlebar clamps. Mount and tighten screws **1** evenly.

Guideline

Screw, handlebar clamp	M8	20 Nm (14.8 lbf ft)
------------------------	----	------------------------

**Info**  
 Make sure the gap width is even.

## 7.3 Adjusting the basic position of the clutch lever

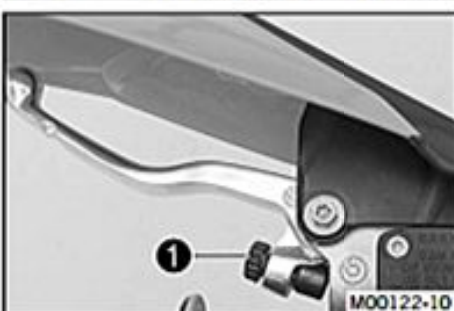

- Adjust the basic setting of the clutch lever to your hand size by turning adjusting screw **1**.

**Info**  
 Turn the adjusting screw clockwise to increase the distance between the clutch lever and the handlebar.  
 Turn the adjusting screw counterclockwise to decrease the distance between the clutch lever and the handlebar.  
 The range of adjustment is limited.  
 Turn the adjusting screw by hand only, and do not apply any force.  
 Do not make any adjustments while riding!

## 7.4 Checking throttle cable routing



### Preparatory work

- Remove the seat. (☞ p. 93)
- Remove the fuel tank. (☞ p. 94)

### Main work

(EXC EU/AUS, EXC SIX DAYS, EXC Factory Edition, XC-W)

- Check throttle cable routing.

Both throttle cables must be routed to the throttle valve body side by side behind the handlebars and above the fuel tank bearing.

- If the throttle cable routing is not as specified:
  - Correct throttle cable routing.



(500 EXC US)

- Check throttle cable routing.

Both throttle cables must be routed to the throttle valve body side by side behind the handlebars and above the fuel tank bearing.

- If the throttle cable routing is not as specified:
  - Correct throttle cable routing.

### Finishing work

- Install the fuel tank. (☞ p. 95)
- Mount the seat. (☞ p. 94)

## 7.5 Checking the play in the throttle cable

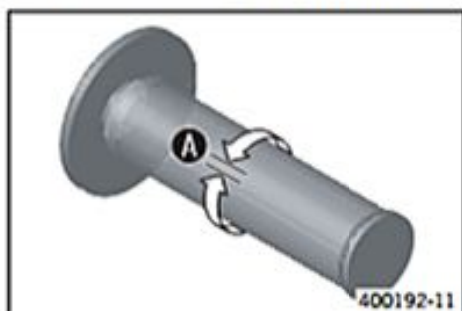

- Check the throttle grip for smooth operation.
- Move the handlebar to the straight-ahead position. Move the throttle grip back and forth slightly to ascertain play **A** in the throttle cable.

Play in throttle cable	3... 5 mm (0.12... 0.2 in)
------------------------	----------------------------

- If the throttle cable play does not meet specifications:
  - Adjust the play in the throttle cable. (☞ p. 61)

**Danger**

**Danger of poisoning** Exhaust gases are toxic and inhaling them may result in unconsciousness and/or death.

- When running the engine, always make sure there is sufficient ventilation, and do not start or run the engine in an enclosed space without an effective exhaust extraction system.

- Start the engine and let it run idle. Move the handlebar to and fro over the entire steering range.

The idle speed must not change.

- If the idle speed changes:
  - Adjust the play in the throttle cable. (☞ p. 61)

## 7.6 Adjusting the play in the throttle cable

**Preparatory work**

- Remove the seat. (☞ p. 93)
- Remove the fuel tank. (☞ p. 94)
- Check throttle cable routing. (☞ p. 60)

**Main work**

(EXC EU/AUS, EXC SIX DAYS, EXC Factory Edition, XC-W)

- Move the handlebar to the straight-ahead position.
- Push back sleeves ①.
- Loosen nut ②. Turn adjusting screw ③ in as far as possible.
- Loosen nut ④. Turn adjusting screw ⑤ so that there is play in the throttle cable at the throttle grip.

**Guideline**

Play in throttle cable	3... 5 mm (0.12... 0.2 in)
------------------------	----------------------------

- Tighten nut ④.
- Press and hold the throttle grip in the closed setting. Turn adjusting screw ③ out until there is no play in throttle cable ⑥.
- Tighten nut ②.
- Slide on sleeves ①. Check the throttle grip for smooth operation.

(500 EXC US)

- Detach rubber strap ①.
- Hang activated charcoal filter ② to the side.

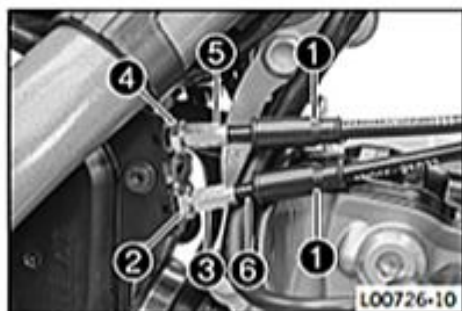

- Move the handlebar to the straight-ahead position.
- Push back sleeves ③.
- Loosen nut ④. Turn adjusting screw ⑤ in as far as possible.
- Loosen nut ⑥. Turn adjusting screw ⑦ so that there is play in the throttle cable at the throttle grip.

**Guideline**

Play in throttle cable	3... 5 mm (0.12... 0.2 in)
------------------------	----------------------------

- Tighten nut ⑥.
- Press and hold the throttle grip in the closed setting. Turn adjusting screw ⑤ out until there is no play in throttle cable ⑧.
- Tighten nut ④.
- Slide on sleeves ③. Check the throttle grip for smooth operation.



- Position activated charcoal filter ②.
- Reconnect rubber band ①.

### Finishing work

- Install the fuel tank. (☛ p. 95)
- Mount the seat. (☛ p. 94)
- Check the play in the throttle cable. (☛ p. 60)



## 8.1 Checking the frame



- Check the frame for cracking and deformation.
- » If the frame exhibits cracking or deformation due to a mechanical impact:
  - Change the frame.



### Info

Always replace a frame that has been damaged due to a mechanical impact. Repair of the frame is not authorized by KTM.

## 8.2 Removing the engine guard (EXC AU, EXC Factory Edition, EXC Six Days)



- Turn quick release ❶ counterclockwise until it disengages. Remove the engine guard.

## 8.3 Installing the engine guard (EXC AU, EXC Factory Edition, EXC Six Days)



- Attach the engine guard on the frame at the rear and swing up at the front.
- Turn quick release ❶ clockwise all the way.

## 9.1 Adjusting the high-speed compression damping of the shock absorber

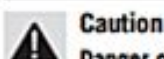

**Caution**

**Danger of accidents** Disassembly of pressurized parts can lead to injury.

- The shock absorber is filled with high density nitrogen. Adhere to the description provided.

**Info**

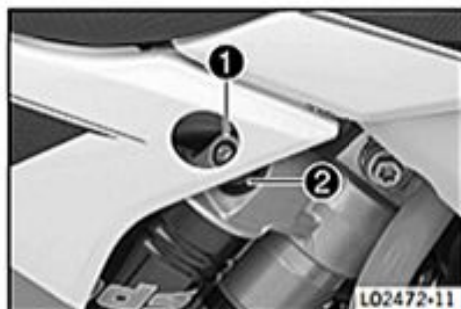
The high-speed setting can be seen during the fast compression of the shock absorber.



- Turn adjusting screw ① all the way clockwise with a socket wrench.

**Info**

Do not loosen nut ②!

- Turn counterclockwise by the number of turns corresponding to the shock absorber type.

**Guideline**

Compression damping, high-speed	
Comfort	2 turns
Standard	1.5 turns
Sport	1.25 turns

**Info**

Turn clockwise to increase damping; turn counterclockwise to reduce damping.

## 9.2 Adjusting the low-speed compression damping of the shock absorber

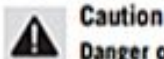
**Caution**

**Danger of accidents** Disassembly of pressurized parts can lead to injury.

- The shock absorber is filled with high density nitrogen. Adhere to the description provided.

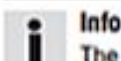
**Info**

The low-speed setting can be seen during the slow to normal compression of the shock absorber.



- Turn adjusting screw ① clockwise with a screwdriver up to the last perceptible click.

**Info**

Do not loosen nut ②!

- Turn counterclockwise by the number of clicks corresponding to the shock absorber type.

**Guideline**

Compression damping, low-speed	
Comfort	25 clicks
Standard	20 clicks
Sport	15 clicks

**Info**

Turn clockwise to increase damping; turn counterclockwise to reduce damping.

## 9.3 Adjusting the rebound damping of the shock absorber

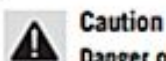
**Caution**

**Danger of accidents** Disassembly of pressurized parts can lead to injury.

- The shock absorber is filled with high density nitrogen. Adhere to the description provided.



- Turn adjusting screw **1** clockwise up to the last perceptible click.

**Info**

Do not loosen nut **2**!

- Turn counterclockwise by the number of clicks corresponding to the shock absorber type.

**Guideline**

Rebound damping	
Comfort	28 clicks
Standard	24 clicks
Sport	22 clicks

**Info**

Turn clockwise to increase damping; turn counterclockwise to reduce damping.

## 9.4 Measuring rear wheel sag unloaded

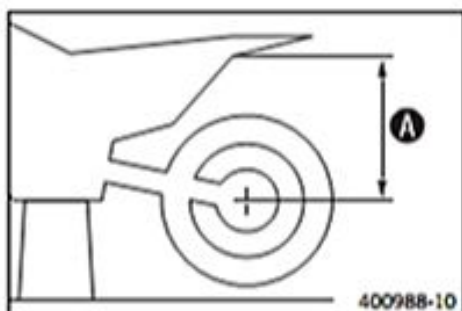
**Preparatory work**

- Raise the motorcycle with the lift stand. (☛ p. 11)

**Main work**

- Measure the distance – as vertically as possible – between the rear axle and a fixed point such as a mark on the side cover.
- Make note of the value as measurement **A**.

**Finishing work**

- Remove the motorcycle from the lift stand. (☛ p. 11)

## 9.5 Checking the static sag of the shock absorber

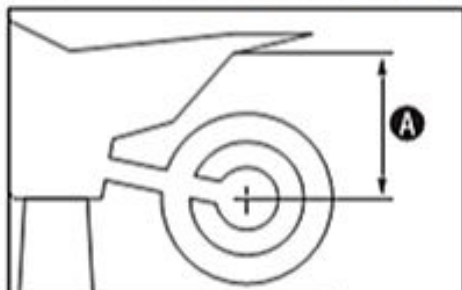

- Measure distance **A** of rear wheel unloaded. (☛ p. 65)
- Hold the motorcycle upright with the aid of an assistant.
- Measure the distance between the rear axle and the fixed point again.
- Note down the value as dimension **B**.



**Info**

The static sag is the difference between measurements **A** and **B**.

- Check the static sag.

Static sag	33... 35 mm (1.3... 1.38 in)
------------	------------------------------

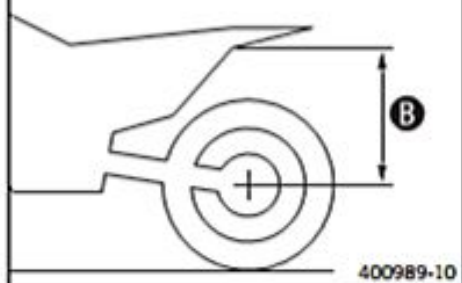
- If the static sag is less or more than the specified value:
  - Adjust the spring preload of the shock absorber. (☛ p. 66)



## 9.6 Checking the riding sag of the shock absorber

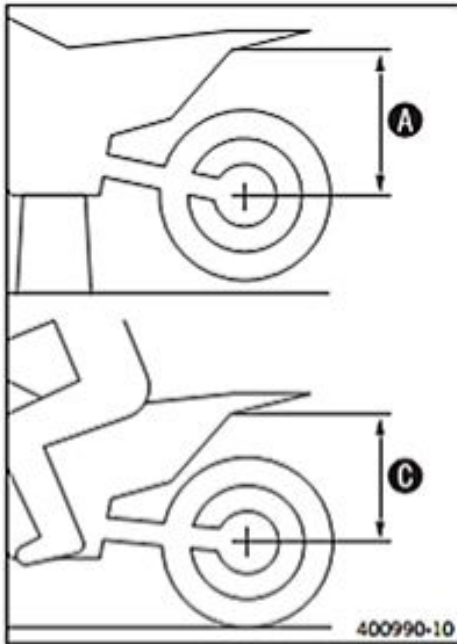

- Measure distance **A** of rear wheel unloaded. (☞ p. 65)
- With another person holding the motorcycle, the rider, wearing full protective clothing, sits on the seat in a normal sitting position (feet on footrests) and bounces up and down a few times.
  - ✓ The rear wheel suspension levels out.
- Another person now measures the distance between the rear axle and a fixed point.
- Note down the value as dimension **C**.

**i Info**

The riding sag is the difference between measurements **A** and **C**.

- Check the riding sag.

Riding sag	105... 115 mm (4.13... 4.53 in)
------------	---------------------------------

- If the riding sag differs from the specified measurement:
  - Adjust the riding sag. (☞ p. 67)

## 9.7 Adjusting the spring preload of the shock absorber

**⚠ Caution**

**Danger of accidents** Disassembly of pressurized parts can lead to injury.

- The shock absorber is filled with high density nitrogen. Adhere to the description provided.

**i Info**

Before changing the spring preload, make a note of the present setting, e.g., by measuring the length of the spring.

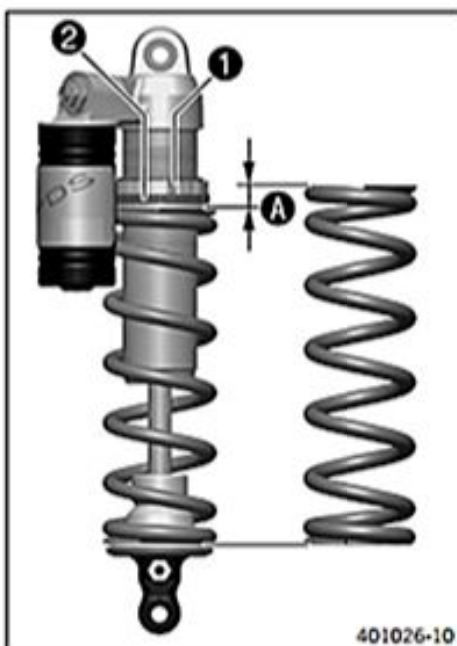

**Preparatory work**

- Raise the motorcycle with the lift stand. (☞ p. 11)
- Remove shock absorber. (☞ p. 67)
- After removing the shock absorber, clean it thoroughly.

**Main work**

- Loosen screw **1**.
- Turn adjusting ring **2** until the spring is no longer under tension.

Hook wrench (T106S) (☞ p. 322)
--------------------------------

- Measure the overall spring length while the spring is not under tension.
- Tighten the spring by turning adjusting ring **2** to measurement **A**.

**Guideline**

Spring preload	
Comfort	9 mm (0.35 in)
Standard	9 mm (0.35 in)
Sport	9 mm (0.35 in)

**i Info**

Depending on the static sag and/or the riding sag, it may be necessary to increase or decrease the spring preload.

- Tighten screw **1**.

**Guideline**

Screw, shock absorber adjusting ring	M5	5 Nm (3.7 lbf ft)
--------------------------------------	----	-------------------

**Finishing work**

- Install the shock absorber. (☞ p. 68)
- Remove the motorcycle from the lift stand. (☞ p. 11)

## 9.8 Adjusting the riding sag



### Preparatory work

- Raise the motorcycle with the lift stand. (☞ p. 11)
- Remove shock absorber. (☞ p. 67)
- After removing the shock absorber, clean it thoroughly.

### Main work

- Choose and mount a suitable spring.

#### Guideline

Spring rate	
Weight of rider: 65... 75 kg (143... 165 lb.)	69 N/mm (394 lb/in)
Weight of rider: 75... 85 kg (165... 187 lb.)	72 N/mm (411 lb/in)
Weight of rider: 85... 95 kg (187... 209 lb.)	76 N/mm (434 lb/in)



### Info

The spring rate is shown on the outside of the spring.  
Smaller weight differences can be compensated by changing the spring preload.

### Finishing work

- Install the shock absorber. (☞ p. 68)
- Remove the motorcycle from the lift stand. (☞ p. 11)
- Check the static sag of the shock absorber. (☞ p. 65)
- Check the riding sag of the shock absorber. (☞ p. 66)
- Adjust the rebound damping of the shock absorber. (☞ p. 65)

## 9.9 Removing the shock absorber



### Preparatory work

- Raise the motorcycle with the lift stand. (☞ p. 11)

### Main work

(EXC EU/AUS, EXC SIX DAYS, EXC Factory Edition, XC-W)

- Remove screw ① and lower the rear wheel with the swingarm as far as possible without blocking the rear wheel. Fix the rear wheel in this position.
- Remove screw ②, push splash protector ③ to the side, and remove the shock absorber.

(500 EXC US)

- Remove screw ① and lower the rear wheel with the swingarm as far as possible without blocking the rear wheel. Fix the rear wheel in this position.
- Remove screw ②, push splash protector ③ to the side, and remove the shock absorber.



## 9.10 Installing the shock absorber



### Main work

(EXC EU/AUS, EXC SIX DAYS, EXC Factory Edition, XC-W)

- Push splash protector **1** to the side and position the shock absorber. Mount and tighten screw **2**.

### Guideline

Screw, top shock absorber	M12	80 Nm (59 lbf ft)	Loctite® 2701™
---------------------------	-----	----------------------	----------------

- Mount and tighten screw **3**.

### Guideline

Screw, bottom shock absorber	M12	80 Nm (59 lbf ft)	Loctite® 2701™
------------------------------	-----	----------------------	----------------



### Info

The heim joint for the shock absorber at the swingarm is Teflon coated. It must not be greased with grease or with other lubricants. Lubricants dissolve the Teflon coating, thereby drastically reducing the service life.



(500 EXC US)

- Push splash protector **1** to the side and position the shock absorber. Mount and tighten screw **2**.

### Guideline

Screw, top shock absorber	M12	80 Nm (59 lbf ft)	Loctite® 2701™
---------------------------	-----	----------------------	----------------

- Mount and tighten screw **3**.

### Guideline

Screw, bottom shock absorber	M12	80 Nm (59 lbf ft)	Loctite® 2701™
------------------------------	-----	----------------------	----------------



### Info

The heim joint for the shock absorber at the swingarm is Teflon coated. It must not be greased with grease or with other lubricants. Lubricants dissolve the Teflon coating, thereby drastically reducing the service life.

### Finishing work

- Remove the motorcycle from the lift stand. (☛ p. 11)

## 9.11 Servicing the shock absorber



### Caution

**Danger of accidents** Disassembly of pressurized parts can lead to injury.

- The shock absorber is filled with high density nitrogen. Adhere to the description provided.

### Condition

The shock absorber has been removed.

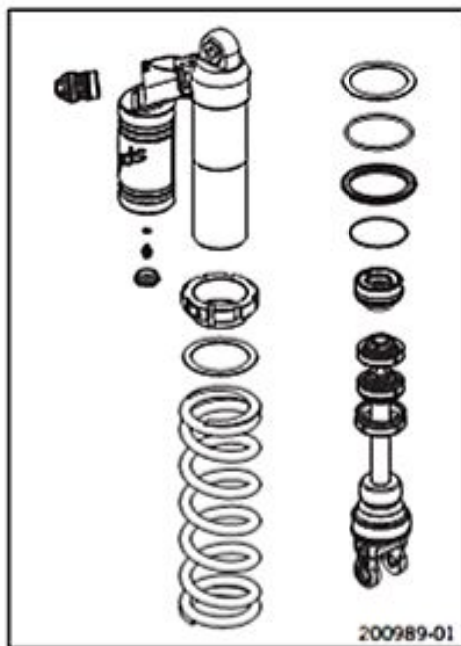

- Remove the spring. (☞ p. 69)
- Disassemble the damper. (☞ p. 69)
- Disassemble the piston rod. (☞ p. 71)
- Disassemble the seal ring retainer. (☞ p. 72)
- Check the damper. (☞ p. 73)
- Disassemble the rebound adjuster. (☞ p. 74)
- Remove the heim joint. (☞ p. 75)
- Install the heim joint. (☞ p. 75)
- Assemble the rebound adjuster. (☞ p. 76)
- Assemble the seal ring retainer. (☞ p. 77)
- Assemble the piston rod. (☞ p. 77)
- Assemble the damper. (☞ p. 79)
- Install the spring. (☞ p. 84)

## 9.12 Removing the spring

### Condition

The shock absorber has been demounted.

- Clamp the shock absorber in a bench vise using soft jaws.
- Measure and note down the spring length in a preloaded state.
- Loosen screw ①.
- Turn the adjusting ring until the spring is no longer under tension.

Hook wrench (T106S) (☞ p. 322)



- Remove O-ring ②.
- Remove spring retainer ③ and intermediate washer ④.
- Remove the spring.

## 9.13 Disassembling the damper

### Preparatory work

- Remove the spring. (☞ p. 69)

### Main work

- Note down the present state of rebound damping ① and compression damping ②.
- Completely open the adjustment elements of the rebound damping and compression damping.
- Remove rubber cap ③ of the reservoir.





- Slowly unscrew screw 4.
- ✓ The pressurized nitrogen is bled off.



- Remove locking cap 5.



- Press seal ring retainer 6 all the way in with the special tool.

Disassembly tool (T1216) (☞ p. 323)

- Remove lock ring 7.

**i Info**  
Do not scratch the inner surface.

- Take out the damper.



- Remove screw 8. Drain the oil.



- Remove the piston rod. Drain the remaining oil.



- Remove adjusting ring 9 with the intermediate washer.





- Remove compression adjuster 10. Remove the spring and piston.

## 9.14 Disassembling the piston rod

### Preparatory work

- Remove the spring. (☞ p. 69)
- Disassemble the damper. (☞ p. 69)

### Main work

- Clamp the piston rod with the fork in a bench vise.

#### Guideline

Use soft jaws.



- Remove nut 1.

**i** Info  
If mount 2 is loosened, apply counteractive force.

- Remove rebound damping shim stack 3.

**i** Info  
Guide the rebound damping shim stack onto a screwdriver and put them aside together.



- Remove piston 4.
- Remove compression damping shim stack 5.

**i** Info  
Guide the compression damping shim stack onto a screwdriver and put them aside together.



- Unscrew and remove mount 2.
- Remove rebound damping shim stack 6.

**i** Info  
Guide the rebound damping shim stack onto a screwdriver and put them aside together.



- Remove piston 7.
- Remove compression damping shim stack 8.

**i** Info  
Guide the compression damping shim stack onto a screwdriver and put them aside together.



- Remove rebound damping washer 9.
- Remove seal ring retainer 10.



- Remove locking cap 11 and bump rubber 12.

## 9.15 Disassembling the seal ring retainer

### Preparatory work

- Remove the spring. (☞ p. 69)
- Disassemble the damper. (☞ p. 69)
- Disassemble the piston rod. (☞ p. 71)

### Main work

- Remove rebound rubber 1.
- Remove centering disk 2.

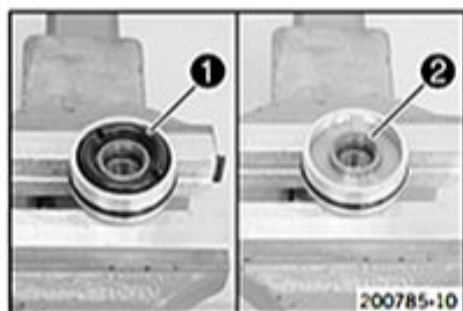

- Remove seal ring 3.
- Remove washer 4 from seal ring 3.

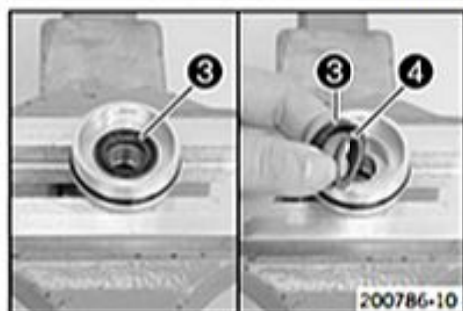

- Remove washer 5.
- Remove O-ring 6.
- Remove dust boot 7.

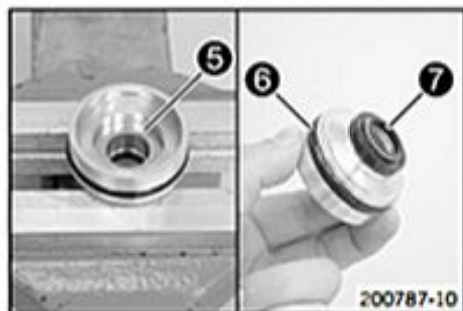

## 9.16 Replacing the pilot bushing

### Preparatory work

- Remove the spring. (☛ p. 69)
- Disassemble the damper. (☛ p. 69)
- Disassemble the piston rod. (☛ p. 71)
- Disassemble the seal ring retainer. (☛ p. 72)

### Main work

- Press pilot bushing ① out of seal ring retainer ② using the special tool.

Press drift (T1504) (☛ p. 326)
--------------------------------

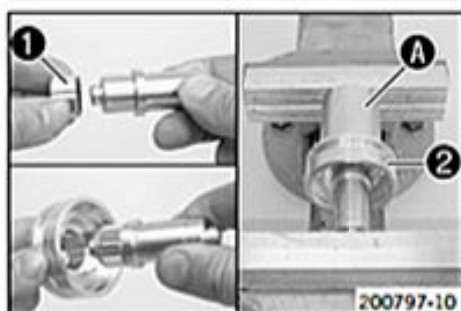
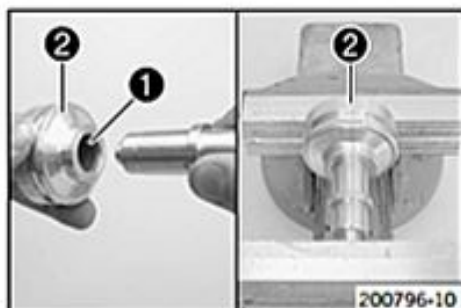

- Slide the new pilot bushing ① onto the special tool.

Press drift (T1504) (☛ p. 326)
--------------------------------

- Position the pilot bushing in the seal ring retainer using the special tool.

Press drift (T1504) (☛ p. 326)
--------------------------------

- Support seal ring retainer ② with the sleeve A of the special tool. Press the pilot bushing all the way in.

Assembly tool (T150S) (☛ p. 326)
----------------------------------

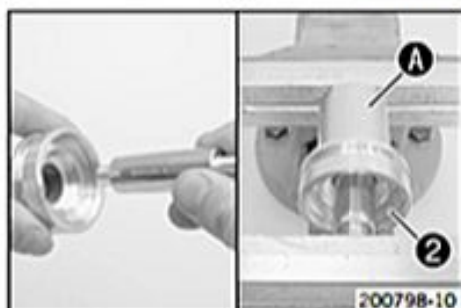

- Lubricate the special tool.

Shock absorber fluid (SAE 2.5) (50180751S1) (☛ p. 310)
--

Calibration pin (T1205) (☛ p. 322)
------------------------------------

- Support seal ring retainer ② with the sleeve A of the special tool.

Assembly tool (T150S) (☛ p. 326)
----------------------------------

- Press the special tool through the new pilot bushing.

Calibration pin (T1205) (☛ p. 322)
------------------------------------

✓ The pilot bushing is to be calibrated.

### Finishing work

- Assemble the seal ring retainer. (☛ p. 77)

## 9.17 Checking the damper

### Condition

The damper has been disassembled.

- Measure the inside diameter on both ends and in the middle of the damper cartridge.

Damper cartridge	
Diameter	50.08 mm (1.9716 in)

Diameter	50.08 mm (1.9716 in)
----------	----------------------

- If the measured value is greater than the specified value:
    - Replace the damper cartridge.
- Check the damper cartridge for damage and wear.
  - If there is damage or wear:
    - Replace the damper cartridge.
- Check the heim joint for damage and wear.
  - If there is damage or wear:
    - Replace the heim joint.





- Measure the diameter of the piston rod.

Piston rod	
Diameter	17.95 mm (0.7067 in)

- If the measured value is smaller than the specified value:
  - Replace the piston rod.

- Measure the run-out of the piston rod.

Piston rod	
Run-out	0.02 mm (0.0008 in)

- If the measured value is greater than the specified value:
  - Replace the piston rod.

- Check the piston rod for damage and wear.

- If there is damage or wear:
  - Replace the piston rod.

- Check the piston rings for damage and wear.

- If damage or a bronze-colored surface is visible:
  - Replace the piston rings.



## 9.18 Disassembling the rebound adjuster

### Preparatory work

- Remove the spring. (☞ p. 69)
- Disassemble the damper. (☞ p. 69)
- Disassemble the piston rod. (☞ p. 71)

### Main work

- Warm up the piston rod in the area of the rebound damping valve seat.

#### Guideline

80 °C (176 °F)
----------------

- Remove rebound damping valve seat ❶.

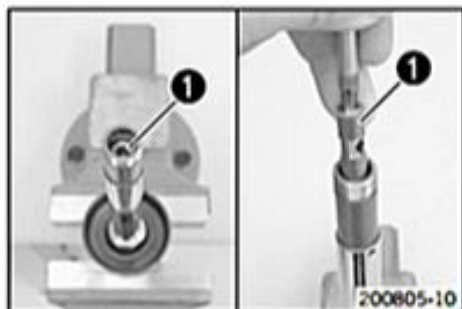

- Remove screwsleeve ❷.
- Remove adjusting screw ❸.

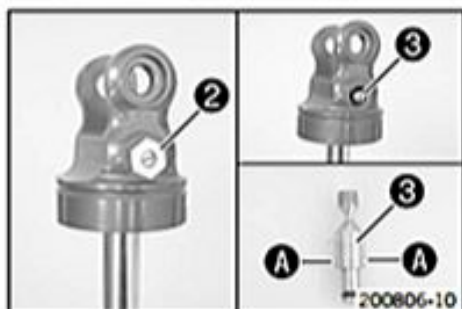

**i Info**  
Do not lose balls ❸ and spring.

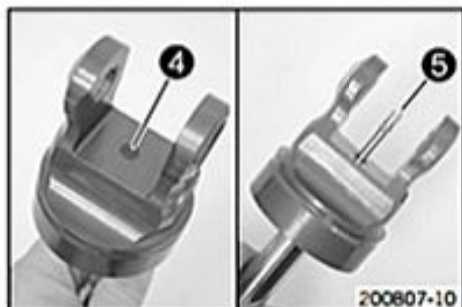

- Remove rubber plug ❹.
- From the opposite side, press rebound needle ❺ out of the piston rod.

## 9.19 Removing the heim joint

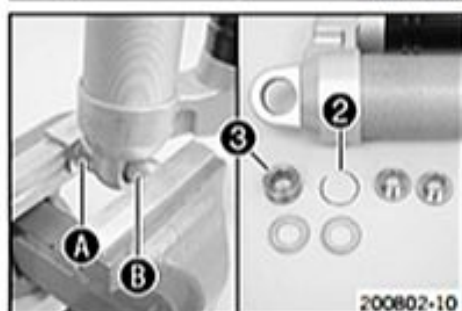
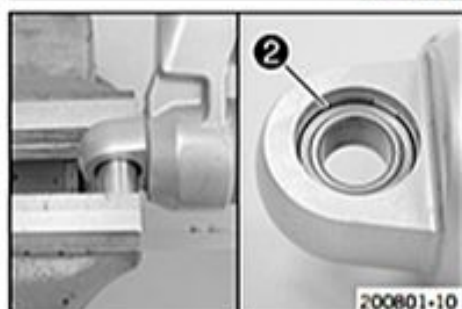
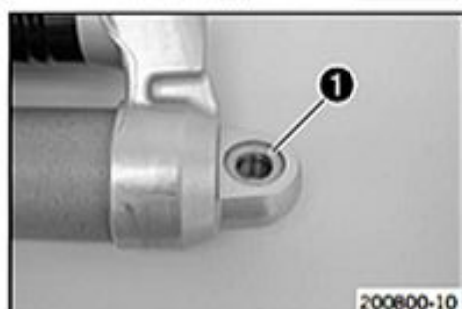
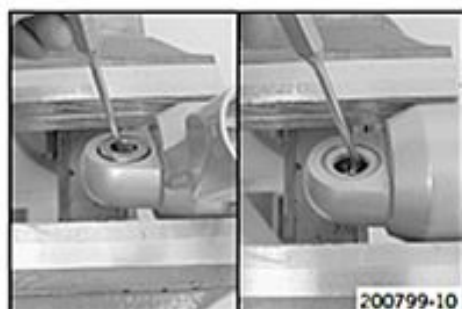
**Condition**

The shock absorber has been demounted.

- Clamp the shock absorber in a vise using soft jaws.
- Remove the collar bushing of the heim joint.

Pin (T120) (☞ p. 322)

- Turn the shock absorber around and remove the second heim joint collar bushing.

- Remove seal ring ① on both sides.

- Press the heim joint against a lock ring using the special tool.

Pressing tool (T1207S) (☞ p. 323)

- Remove the second lock ring ②.

- Place special tool A underneath and press out heim joint ③ using special tool B.

Pressing tool (T1207S) (☞ p. 323)

## 9.20 Installing the heim joint



- Position new heim joint ① and special tool.

Pressing tool (T1206) (☞ p. 323)

- Press in the heim joint all the way.

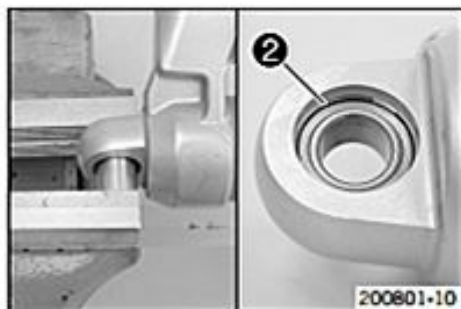

- Press the heim joint against the lock ring using the special tool.

Pressing tool (T1207S) (☛ p. 323)

- Mount the second lock ring (2).

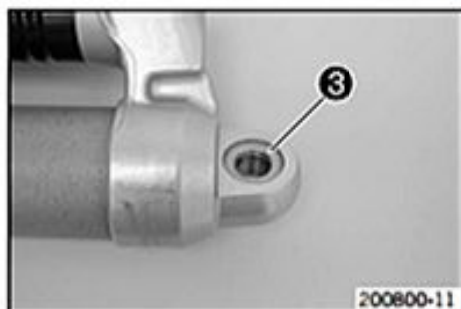

- Mount seal ring (3) on both sides.

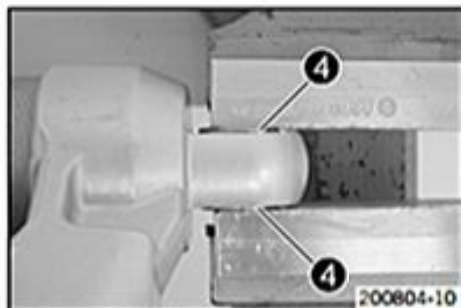

- Position both collar bushings (4) and press in.

## 9.21 Assembling the rebound adjuster

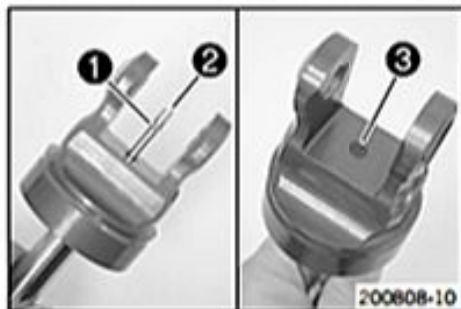

- Grease O-ring (1) of the rebound needle.

Lubricant (T158) (☛ p. 311)

- Mount rebound needle (2) in the piston rod.



### Info

Push in the rebound needle to the point where it is possible to mount the rebound damping adjusting screw.

- Mount rubber plug (3).

- Lubricate spring, balls (4) and O-ring (5).

Lubricant (T159) (☛ p. 311)

- Screw in the rebound damping adjusting screw (6) all the way.

- Mount and tighten screw sleeve (7).

### Guideline

Screw sleeve	M14x1	18 Nm (13.3 lbf ft)
--------------	-------	------------------------

- Screw out the rebound damping adjusting screw (6) to the stop.

- Grease the O-ring of the rebound damping seat.

Lubricant (T159) (☛ p. 311)

- Mount and tighten rebound damping valve seat (8).

### Guideline

Rebound damping valve seat	M8x1	6 Nm (4.4 lbf ft)	Loctite® 2701™
----------------------------	------	----------------------	----------------

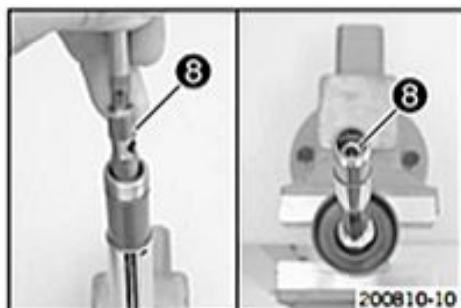



**Info**

The rebound damping valve seat must be pressed inward before tightening.

## 9.22 Assembling the seal ring retainer



- Mount dust boot 1 with the special tool.

Mounting sleeve (T1204) (☞ p. 322)

- Grease the sealing lip of the dust boot.

Lubricant (T625) (☞ p. 311)

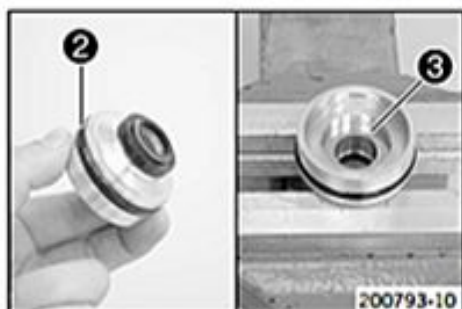

- Grease the O-ring groove.

Lubricant (T158) (☞ p. 311)

- Mount O-ring 2.
- Mount washer 3.

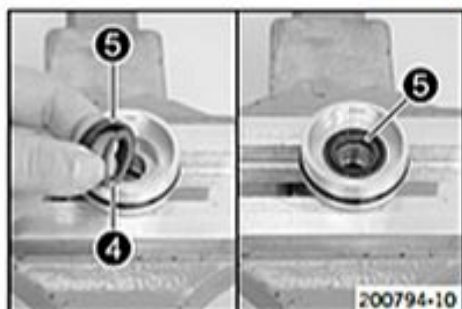

- Position washer 4 on seal ring 5.
- Grease the seal ring and mount with the washer facing downward.

Lubricant (T511) (☞ p. 311)

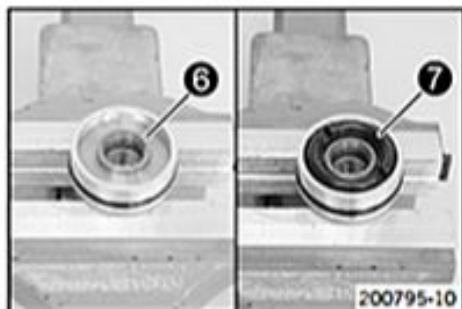

- Mount centering disk 6.
- Mount rebound rubber 7.

## 9.23 Assembling the piston rod

**Preparatory work**

- Assemble the seal ring retainer. (☞ p. 77)
- Assemble the rebound adjuster. (☞ p. 76)

**Main work**

- Clamp the piston rod with the fork in a bench vise.

**Guideline**

Use soft jaws.



- Mount bump rubber 1 and locking cap 2.
- Position the special tool on the piston rod.

Mounting sleeve (T1215) (☞ p. 323)

- Grease the dust boot and slide seal ring retainer ③ onto the piston rod.

Lubricant (T625) (☛ p. 311)

- Remove the special tool.
- Mount rebound damping washer ④.
- Mount the compression shim stack ⑤ with the smaller shims facing downward.



- Grind piston ⑥ on both sides, using 1200 grit sandpaper on a surfacing plate.
- Clean the piston.
- Mount the piston.

Guideline

View A	Top view of piston
View B	Bottom view of piston



- Mount rebound damping shim stack ⑦ with the smaller shims at the top.
- Apply thread locker to the threads of the piston rod.

Loctite® 2701™

- Screw on mount ⑧ to the point where the piston can still be turned.



- Mount the compression shim stack ⑨ with the smaller shims facing downward.



- Grind piston ⑩ on both sides on a surface plate using 1200 grit sandpaper.
- Clean the piston.
- Mount the piston.

Guideline

View A	Top view of piston
View B	Bottom view of piston





- Mount rebound damping shim stack **11** with the smaller shims facing upward.
- Grease the threads of the mount.

Lubricant (T152) (☞ p. 311)

- Mount nut **12**, but do not tighten it yet.



- Align both pistons using the special tool.

Centering sleeve (T1214) (☞ p. 323)

- Tighten the nut.

Guideline

Piston rod nut	M16x1	40 Nm (29.5 lbf ft)
----------------	-------	------------------------

- Remove the special tool.

## 9.24 Assembling the damper

### Preparatory work

- Assemble the seal ring retainer. (☞ p. 77)
- Assemble the rebound adjuster. (☞ p. 76)
- Assemble the piston rod. (☞ p. 77)

### Main work

- Slide the spring and piston onto compression adjuster **1**.
- Grease the O-ring.

Lubricant (T158) (☞ p. 311)

- Grease the threads.

Lubricant (T159) (☞ p. 311)

- Mount and tighten the compression adjuster.

Guideline

Compression adjuster	M31x1	50 Nm (36.9 lbf ft)
----------------------	-------	------------------------

- Install adjusting ring **2** with an intermediate washer.

**i** Info

The adjusting ring cannot be mounted after the piston rod has been assembled!



- Mount screw **3** but do not tighten yet.



- Grease the O-ring of the seal ring retainer.

Lubricant (T158) (☛ p. 311)

- Fill the damper cartridge approximately half way.

Shock absorber fluid (SAE 2.5) (50180751S1) (☛ p. 310)

- Carefully mount the piston rod.



- Mount seal ring retainer 4 and slide it under the ring groove.
- Mount lock ring 5.

**i Info**

Do not scratch the inner surface.

- Pull out the piston rod in order that the seal ring retainer fits closely against the lock ring.



- Mount locking cap 6 of the damper cartridge.
- Bleed and fill the damper. (☛ p. 81)
- Fill the damper with nitrogen. (☛ p. 83)



- Mount rubber cap 7 of the reservoir.
- Turn adjusting ring 8 completely down toward the bottom.



**Alternative 1**

- Turn adjusting screw 9 clockwise with a screwdriver up to the last perceptible click.
- Turn counterclockwise by the number of clicks corresponding to the shock absorber type.

**Guideline**

Compression damping, low-speed	
Comfort	25 clicks
Standard	20 clicks
Sport	15 clicks

- Turn adjusting screw 10 clockwise with an open end wrench until it stops.
- Turn counterclockwise by the number of turns corresponding to the shock absorber type.

**Guideline**

Compression damping, high-speed	
Comfort	2 turns
Standard	1.5 turns
Sport	1.25 turns

- Turn adjusting screw 11 clockwise up to the last perceptible click.
- Turn counterclockwise by the number of clicks corresponding to the shock absorber type.

**Guideline**

Rebound damping	
Comfort	28 clicks
Standard	24 clicks
Sport	22 clicks

**Alternative 2**



**Warning**

**Danger of accident** Modifications to the suspension setting may seriously alter the handling characteristic.

Extreme modifications to the suspension setting may cause a serious deterioration in the handling characteristic and overload components.

- Only make adjustments within the recommended range.
  - Ride slowly to start with after making adjustments to get the feel of the new handling characteristic.
- 
- Mount adjusting screws 9, 10 and 11 in the positions determined when disassembling.

## 9.25 Bleeding and filling the damper



**Info**

Before working with the vacuum pump, carefully read the vacuum pump operating manual. Completely open the adjusters of the rebound and compression damping.



- Remove the screw from the filling port.
- Mount adapter 1 on the damper.



**Info**

Hand-tighten only without using a tool.

- Connect adapter 1 to connector 2 of the vacuum pump.

Vacuum pump (T1240S) (☞ p. 324)

- Clamp the damper with soft jaws or hold it as shown in the photo.



**Info**

Clamp the damper only lightly.

The filling port must be located at the highest point.

The piston rod moves in and out during filling; do not immobilize it by holding it with your hand.



- Position the control lever as shown in the photo.

- ✓ Control lever External tank 3 is set to Closed; Damper 4 is set to Vacuum; and Oil reservoir 5 is set to Vacuum.

- Activate On/Off switch 6.

- ✓ The suction process begins.
- ✓ Pressure gauge 7 drops to the required value.

< 0 bar

- ✓ Vacuum gauge 8 drops to the required value.

4 mbar



- Determine distance **A** between the floating piston and reservoir hole with the special tool.

Depth micrometer (T107S) (☛ p. 322)

- ✓ The floating piston is positioned in the lowermost position.



- When the vacuum gauge reaches the required value, turn control lever **Oil reservoir** **5** to **Equalize pressure**.

Guideline

4 mbar

- ✓ The pressure gauge increases to the required value.

0 bar

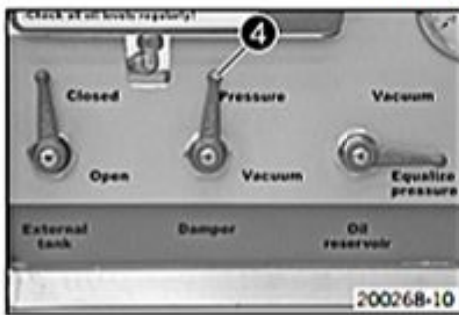

- When the pressure gauge reaches the required value, turn control lever **Damper** **4** to **Pressure**.

Guideline

0 bar

- ✓ Oil is pumped into the damper.

- ✓ The pressure gauge increases to the required value.

3 bar

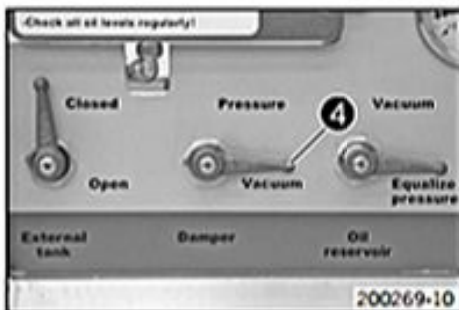

- When the pressure gauge reaches the required value, turn control lever **Damper** **4** to **Vacuum**.

Guideline

3 bar

- ✓ The pressure gauge drops to the required value.

0 bar



- When the pressure gauge reaches the required value, turn control lever **Oil reservoir** **5** to **Vacuum**.

Guideline

0 bar

- ✓ The vacuum gauge drops to the required value.

8 mbar

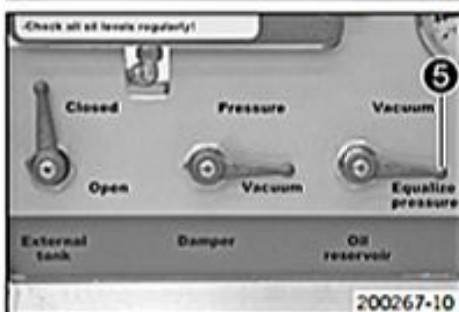

- When the vacuum gauge reaches the required value, turn control lever **Oil reservoir** **5** to **Equalize Pressure**.

Guideline

8 mbar

- ✓ The pressure gauge drops to the required value.

0 bar

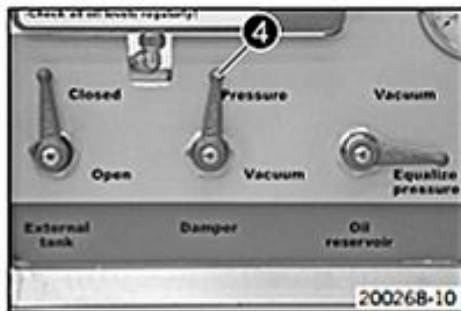

- When the pressure gauge reaches the required value, turn control lever **Damper 4** to **Pressure**.

Guideline

0 bar

- ✓ Oil is pumped into the damper.
- ✓ The pressure gauge increases to the required value.

3 bar

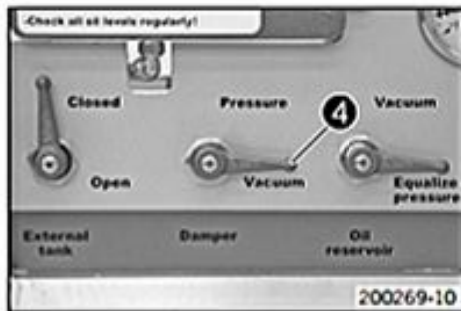

- When the pressure gauge reaches the required value, turn control lever **Damper 4** to **Vacuum**.

Guideline

3 bar

- ✓ The pressure gauge drops to the required value.

0 bar

- When the pressure gauge reaches the required value, activate the **On/Off** switch.

Guideline

0 bar

- ✓ The vacuum pump is switched off.

- Slide O-ring **B** to the end of the special tool by the specified value (distance **A** minus specified value).

Guideline

10 mm

Depth micrometer (T107S) (☞ p. 322)

- Push the floating piston into the reservoir to the distance described above using the special tool.

**i** **Info**

When the piston rod is fully extended, the floating piston must be at precisely this position; otherwise, damage will occur when the shock absorber compresses and rebounds.

- Remove the special tool.

- Remove adapter **1** from connector **2** of the vacuum pump.

**i** **Info**

Hold the damper so that the filling port is at the highest point.

- Remove the adapter.

- Mount and tighten screw **9**.

Guideline

Filling port screw	M10x1	14 Nm (10.3 lbf ft)
--------------------	-------	------------------------

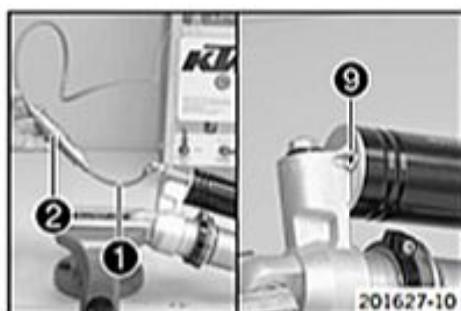
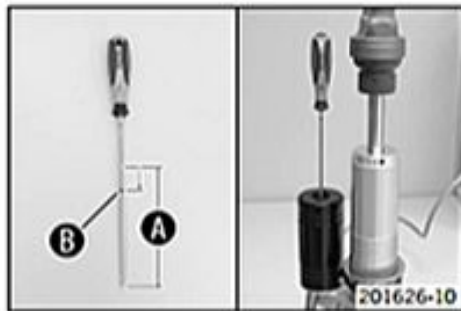

## 9.26 Filling the damper with nitrogen



- Screw in the screw **1** approx. two turns, but do not tighten.

**i** **Info**

The piston rod is completely extended.

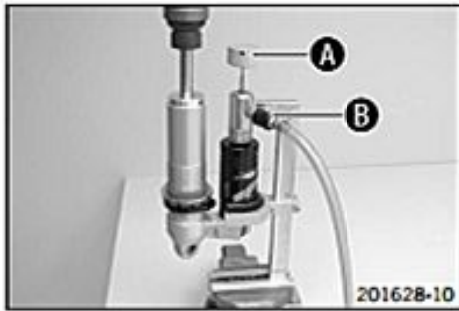

- Keep the special tool in place in the bench vise.

Nitrogen filling tool (T170S1) (☛ p. 326)

- Connect the special tool to the pressure regulator of the filling cylinder.

Filling gas - nitrogen

- Adjust the pressure regulator.

Guideline

Gas pressure	10 bar (145 psi)
--------------	------------------

- Position the shock absorber in the special tool.

- ✓ The hexagonal part of tap handle **A** engages in the hexagon socket of the screw of the filling port.

- Open spigot **B**.

- Fill the shock absorber for at least 15 seconds.

Guideline

Gas pressure	10 bar (145 psi)
--------------	------------------



**Info**

Monitor the pressure control valve indicator.  
Ensure that the shock absorber has been filled to the specified pressure.

- Screw the filling port shut with tap handle **A**.

- Close spigot **B** and remove the damper from the special tool.

- Tighten the screw of the filling port.

Guideline

Reservoir filling port screw	M5	3.5 Nm (2.58 lbf ft)
------------------------------	----	-------------------------

## 9.27 Installing the spring



- Ensure that adjusting ring **1** is screwed on with the intermediate washer.



- Measure the overall spring length when not under tension.

- Position the spring.

Guideline

Spring rate	
Weight of rider: 65... 75 kg (143... 165 lb.)	69 N/mm (394 lb/in)
Weight of rider: 75... 85 kg (165... 187 lb.)	72 N/mm (411 lb/in)
Weight of rider: 85... 95 kg (187... 209 lb.)	76 N/mm (434 lb/in)

- Mount intermediate washer **2** and spring retainer **3**.

- Mount ring **4**.

**Alternative 1**

- Tighten the spring by turning adjusting ring to measurement.

## Guideline

Spring preload	
Comfort	9 mm (0.35 in)
Standard	9 mm (0.35 in)
Sport	9 mm (0.35 in)

Hook wrench (T106S) (☞ p. 322)

## Alternative 2

**Warning**

**Danger of accident** Modifications to the suspension setting may seriously alter the handling characteristic.

Extreme modifications to the suspension setting may cause a serious deterioration in the handling characteristic and overload components.

- Only make adjustments within the recommended range.
  - Ride slowly to start with after making adjustments to get the feel of the new handling characteristic.
- 
- Tighten the spring by turning the adjusting ring to the measured value determined when it was removed.

Hook wrench (T106S) (☞ p. 322)

- Tighten screw ⑤.

## Guideline

Screw, shock absorber adjusting ring	M5	5 Nm (3.7 lbf ft)
--------------------------------------	----	-------------------



## 9.28 Changing the heim joint

## Preparatory work

- Raise the motorcycle with the lift stand. (☞ p. 11)

## Main work

- Remove screw ① and lower the rear wheel with the swingarm as far as possible without blocking the rear wheel. Fix the rear wheel in this position.

**Info**

Raise the wheel slightly to make it easier to remove the screw.

- Swing back the shock absorber.
- Remove spacers ② on both sides.





- Remove shaft seal rings **3** on both sides.



- Mount special tool **4**.

Mounting tool, heim joint (50329000044) (☛ p. 314)

- Press out the heim joint by screwing in the screw.



- Position the new heim joint.

- Mount special tool **4**.

Mounting tool, heim joint (50329000044) (☛ p. 314)

- Press in the heim joint by screwing in the screw.



- Press in shaft seal rings **3** on both sides with the open side facing inward.

**Info**

The heim joint for the shock absorber at the swingarm is Teflon coated. It must not be greased with grease or with other lubricants. Lubricants dissolve the Teflon coating, thereby drastically reducing the service life.



- Mount spacers **2** on both sides.



- Position the shock absorber.

- Mount and tighten screw **1**.

**Guideline**

Screw, bottom shock absorber	M12	80 Nm (59 lbf ft)	Loctite® 2701™
------------------------------	-----	----------------------	----------------

**Info**

Raise the wheel slightly to make it easier to mount the screw.

**Finishing work**

- Remove the motorcycle from the lift stand. (☛ p. 11)



## 10.1 Removing the manifold

## Preparatory work

- Raise the motorcycle with the lift stand. (☞ p. 11)
- Remove shock absorber. (☞ p. 67)
- Remove the main silencer. (☞ p. 88)

## Main work

- Remove springs ❶.



- Disconnect the plug-in connector of the lambda sensor and remove the cable binder.
- Expose the cable.
- Remove screw ❷ and take off the manifold.

## 10.2 Installing the manifold

## Main work

- Position the manifold and mount springs ❶.

Spring hooks (50305017000) (☞ p. 314)
---------------------------------------



- Connect the plug-in connector of the lambda sensor.
- Route the cable loosely and secure with a cable binder.
- Mount and tighten screw ❷.

## Guideline

Remaining screws, chassis	M8	25 Nm (18.4 lbf ft)
---------------------------	----	------------------------

## Finishing work

- Install the main silencer. (☞ p. 88)
- Install the shock absorber. (☞ p. 68)
- Remove the motorcycle from the lift stand. (☞ p. 11)

## 10.3 Removing main silencer

**Warning****Danger of burns** The exhaust system gets very hot when the vehicle is driven.

- Allow the exhaust system to cool down. Do not touch hot components.



- Disconnect spring ①.

Spring hooks (50305017000) (☞ p. 314)
---------------------------------------

- Remove screws ② and take off main silencer.

## 10.4 Installing the main silencer

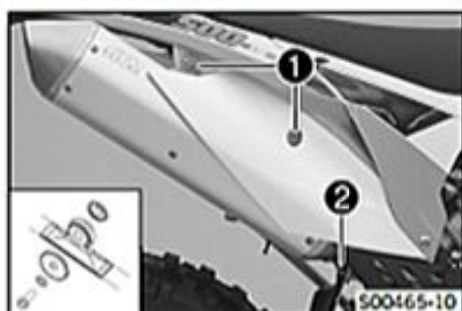

- Position the main silencer. Mount screws ①, but do not tighten yet.
- Reconnect spring ②.

Spring hooks (50305017000) (☞ p. 314)
---------------------------------------

- Tighten screws ①.

**Guideline**

Remaining screws, chassis	M6	10 Nm (7.4 lbf ft)
---------------------------	----	--------------------

## 10.5 Changing glass fiber yarn filling in the main silencer

**Warning****Danger of burns** The exhaust system gets very hot when the vehicle is driven.

- Allow the exhaust system to cool down. Do not touch hot components.

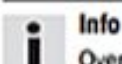
**Info**

Over time, the fibers of the glass fiber yarn escape and the damper "burns" out. Not only is the noise level higher, the performance characteristic changes.

**Preparatory work**

- Remove the main silencer. (☞ p. 88)

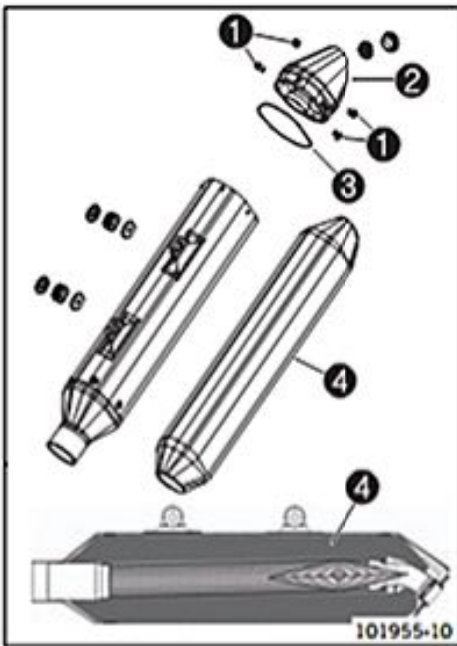
**Main work**
**(EXC EU/AUS, EXC SIX DAYS, EXC Factory Edition)**

- Remove screws ①.
- Take off silencer cap ② with O-ring ③.
- Remove old glass fiber yarn filling.
- Clean the parts that need to be reinstalled and check for damage.
- Fit new glass fiber yarn filling ④ into the main silencer.
- Mount the O-ring on the silencer cap.
- Position the silencer cap.
- Mount and tighten all of the screws.

**Guideline**

Screws on the main silencer	M5	7 Nm (5.2 lbf ft)
-----------------------------	----	-------------------

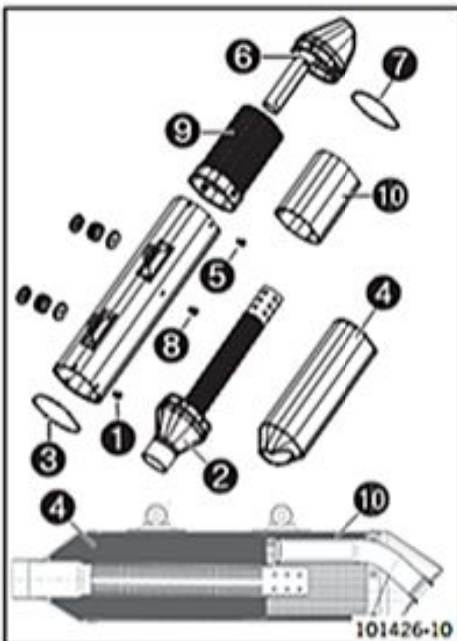
**(XC-W, 500 EXC US)**

- Remove screws ① of connecting cap ②.
- Remove connecting cap ② with the perforated pipe, O-ring ③, and glass fiber yarn filling ④.
- Remove screws ⑤ and silencer cap ⑥ with O-ring ⑦.
- Remove screws ⑧ and insert ⑨ together with insulating pad ⑩.
- Clean the parts that need to be reinstalled and check for damage.
- Mount the new insulating pad on the insert and fasten with adhesive tape.
- Position the insert with the insulating pad in outer tube.
- Mount and tighten screws ⑧.

**Guideline**

Screws on the main silencer	M5	7 Nm (5.2 lbf ft)
-----------------------------	----	-------------------

- Mount O-ring ③ on the silencer cap.
- Fit the new glass fiber yarn filling onto the perforated pipe.
- Fit the connecting cap with the glass fiber yarn filling in the outer tube.

**Info**

Press the glass fiber yarn filling into the outer tube using a blunt tool.

- Mount and tighten screws ①.

**Guideline**

Screws on the main silencer	M5	7 Nm (5.2 lbf ft)
-----------------------------	----	-------------------

- Mount O-ring ⑦ on the silencer cap.
- Position the silencer cap with O-ring ⑦ in the outer tube.
- Mount and tighten screws ⑤.

**Guideline**

Screws on the main silencer	M5	7 Nm (5.2 lbf ft)
-----------------------------	----	-------------------

**Finishing work**

- Install the main silencer. (☛ p. 88)

## 11.1 Removing the air filter box cover

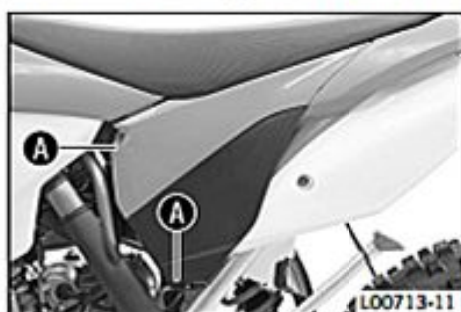

(EXC EU/AUS, EXC SIX DAYS, EXC Factory Edition, XC-W)

- Pull off the air filter box cover in **A** area sideways and remove it toward the front.



(500 EXC US)

- Pull off the air filter box cover in **A** area sideways and remove it toward the front.

## 11.2 Installing the air filter box cover



(EXC EU/AUS, EXC SIX DAYS, EXC Factory Edition, XC-W)

- Insert the air filter box cover into rear area **A** and clip it into front area **B**.

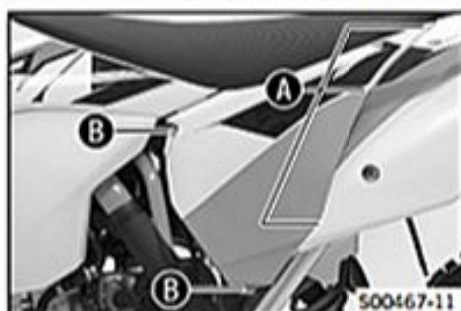

(500 EXC US)

- Insert the air filter box cover into rear area **A** and clip it into front area **B**.

## 11.3 Sealing the air filter box

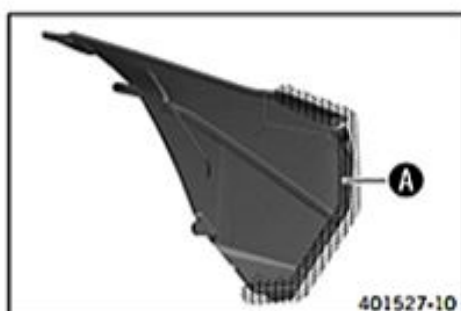

**Preparatory work**

- Remove the air filter box cover. (☛ p. 90)

**Main work**

- Seal the air filter box in the marked area **A**.

**Finishing work**

- Install the air filter box cover. (☛ p. 90)

## 11.4 Removing the air filter

### Note

**Engine failure** Unfiltered intake air has a negative effect on the service life of the engine.

- Never operate the vehicle without an air filter as dust and dirt will enter the engine and lead to increased wear.



### Warning

**Environmental hazard** Hazardous substances cause environmental damage.

- Oil, grease, filters, fuel, cleaners, brake fluid, etc., should be disposed of as stipulated in applicable regulations.



### Preparatory work

- Remove the air filter box cover. (☞ p. 90)

### Main work

- Detach air filter holding bracket **1** at the bottom and swing it to one side. Remove the air filter with the air filter support.
- Remove the air filter from the air filter support.

## 11.5 Installing the air filter

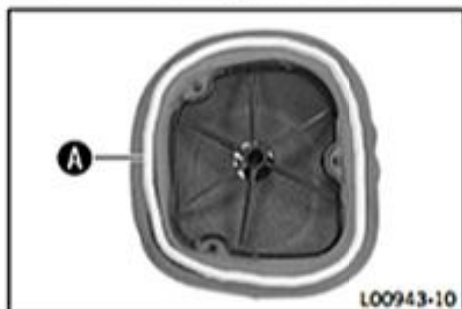

### Main work

- Mount the clean air filter on the air filter support.
- Grease the air filter in area **A**.

Long-life grease (☞ p. 311)

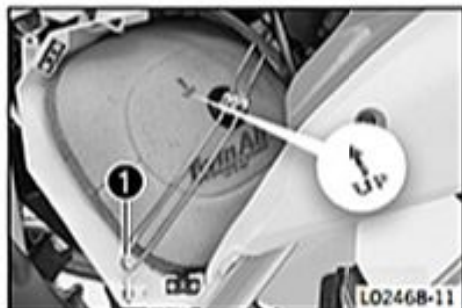

- Insert both parts together, position them and fasten them using the air filter holding bracket **1**.

✓ The arrow of marking **UP** faces up.



### Info

If the air filter is not correctly mounted, dust and dirt can enter the engine and cause damage.

### Finishing work

- Install the air filter box cover. (☞ p. 90)

## 11.6 Cleaning the air filter and air filter box



### Warning

**Environmental hazard** Hazardous substances cause environmental damage.

- Oil, grease, filters, fuel, cleaners, brake fluid, etc., should be disposed of as stipulated in applicable regulations.



### Info

Do not clean the air filter with fuel or petroleum since these substances attack the foam.

### Preparatory work

- Remove the air filter box cover. (☞ p. 90)
- Remove the air filter. (☞ p. 91)



### Main work

- Wash the air filter thoroughly in special cleaning liquid and allow it to dry properly.

Air filter cleaner (☛ p. 311)



### Info

Only press the air filter to dry it, never wring it out.

- Oil the dry air filter with a high quality filter oil.

Oil for foam air filter (☛ p. 312)

- Clean the air filter box.
- Check the intake flange for damage and firm seating.

### Finishing work

- Install the air filter. (☛ p. 91)
- Install the air filter box cover. (☛ p. 90)

## 12.1 Opening filler cap



### Danger

**Fire hazard** Fuel is highly flammable.

- Never refuel the vehicle near open flames or burning cigarettes, and always switch off the engine first. Be careful that no fuel is spilt, especially on hot vehicle components. Clean up spilt fuel immediately.
- The fuel in the fuel tank expands when warm and may emerge if overfilled. Follow the instructions on refueling.



### Warning

**Danger of poisoning** Fuel is poisonous and a health hazard.

- Fuel must not come into contact with the skin, eyes, or clothing. Do not breathe in the fuel vapors. If contact occurs with the eyes, rinse with water immediately and contact a physician. Immediately clean contaminated areas on the skin with soap and water. If fuel is swallowed, contact a physician immediately. Change clothing that has been contaminated with fuel. Store fuel properly in a suitable canister and keep away from children.



### Warning

**Environmental hazard** Improper handling of fuel is a danger to the environment.

- Do not allow fuel to get into the ground water, the ground, or the sewage system.



- Press release button **1**, turn filler cap counterclockwise and lift it upwards and remove.

## 12.2 Closing filler cap

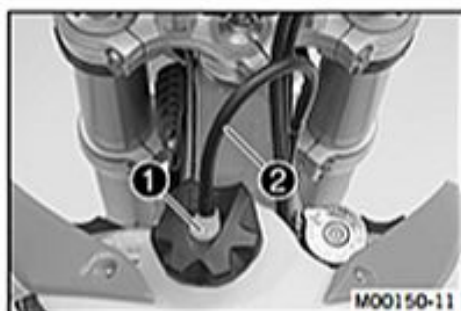

- Replace the filler cap and turn clockwise until the release button **1** locks in place.

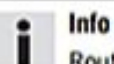

### Info

Route the fuel tank breather hose **2** without kinking.

## 12.3 Removing the seat



- Remove screw **1**.
- Lift up the seat at the rear, pull it back and then remove it from above.

## 12.4 Mounting the seat



- Mount the front the seat on to the collar bushing of the fuel tank, lower it at the rear and simultaneously push it forward.
- Make sure that the seat is correctly locked in.
- Mount and tighten the screw of the seat fixing.

## Guideline

Remaining screws, chassis	M6	10 Nm (7.4 lbf ft)
---------------------------	----	--------------------

## 12.5 Removing the fuel tank

**Danger**

**Fire hazard** Fuel is highly flammable.

- Never refuel the vehicle near open flames or burning cigarettes, and always switch off the engine first. Be careful that no fuel is spilled, especially on hot vehicle components. Clean up spilled fuel immediately.
- The fuel in the fuel tank expands when warm and may emerge if overfilled. Follow the instructions on refueling.

**Warning**

**Danger of poisoning** Fuel is poisonous and a health hazard.

- Fuel must not come into contact with the skin, eyes, or clothing. Do not breathe in the fuel vapors. If contact occurs with the eyes, rinse with water immediately and contact a physician. Immediately clean contaminated areas on the skin with soap and water. If fuel is swallowed, contact a physician immediately. Change clothing that has been contaminated with fuel. Store fuel properly in a suitable canister and keep away from children.

**Preparatory work**

- Remove the seat. (☛ p. 93)

**Main work**

- Detach connector ❶ of the fuel pump.
- Remove the tube from the fuel tank breather.

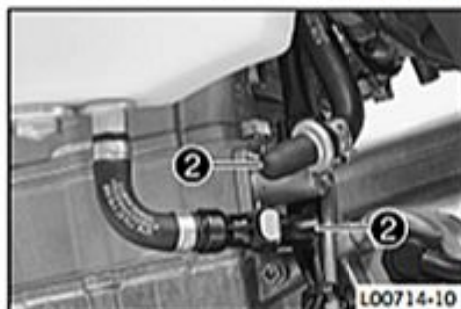
**(EXC EU/AUS, EXC SIX DAYS, EXC Factory Edition, XC-W)**

- Thoroughly clean the plug-in connection of the fuel line using compressed air.

**Info**

Under no circumstances should dirt enter into the fuel line. Dirt in the fuel line clogs the injection valve.

- Disconnect the plug-in connection of the fuel line.
- Mount the wash cap set ❷.

Wash cap set (81212016100)

**(500 EXC US)**

- Thoroughly clean the plug-in connection of the fuel line using compressed air.

**Info**

Under no circumstances should dirt enter into the fuel line. Dirt in the fuel line clogs the injection valve.

- Disconnect the plug-in connection of the fuel line.
- Mount the wash cap set ❷.

Wash cap set (81212016100)





(EXC EU/AUS, EXC SIX DAYS, EXC Factory Edition)

- Disconnect the connector of the horn.
- Remove screws ③ with the collar bushings and horn.

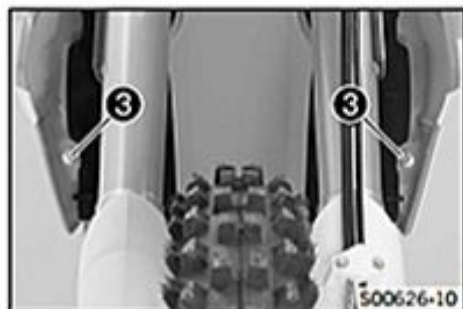

(XC-W, 500 EXC US)

- Remove screws ③ with the collar bushings.



- Remove screw ④ with the rubber bushing.



- Pull both spoilers off of the sides of the radiator bracket and lift off the fuel tank.

### 12.6 Installing the fuel tank



#### Danger

**Fire hazard** Fuel is highly flammable.

- Never refuel the vehicle near open flames or burning cigarettes, and always switch off the engine first. Be careful that no fuel is spilt, especially on hot vehicle components. Clean up spilt fuel immediately.
- The fuel in the fuel tank expands when warm and may emerge if overfilled. Follow the instructions on refueling.



#### Warning

**Danger of poisoning** Fuel is poisonous and a health hazard.

- Fuel must not come into contact with the skin, eyes, or clothing. Do not breathe in the fuel vapors. If contact occurs with the eyes, rinse with water immediately and contact a physician. Immediately clean contaminated areas on the skin with soap and water. If fuel is swallowed, contact a physician immediately. Change clothing that is contaminated with fuel.

#### Main work

- Check throttle cable routing. (☛ p. 60)



MO0182-11

- Position the fuel tank and fit the two spoilers to the sides of the radiator bracket.
- Make sure that no cables are trapped or damaged.
- Mount the fuel tank breather.
- Mount and tighten screw ① with the rubber bushing.

**Guideline**

Remaining screws, chassis	M6	10 Nm (7.4 lbf ft)
---------------------------	----	--------------------

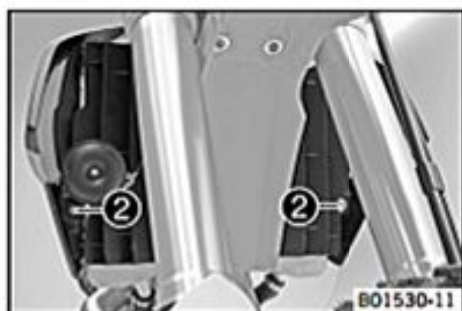

BO1530-11

**(EXC EU/AUS, EXC SIX DAYS, EXC Factory Edition)**

- Position the collar bushings and horn, and mount and tighten screws ②.

**Guideline**

Remaining screws, chassis	M6	10 Nm (7.4 lbf ft)
---------------------------	----	--------------------

- Connect the connector of the horn.

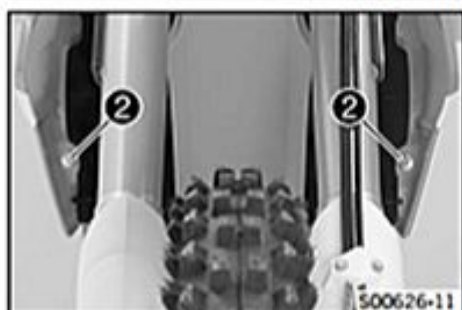

500626-11

**(XC-W, 500 EXC US)**

- Position the collar bushings, and mount and tighten screws ②.

**Guideline**

Remaining screws, chassis	M6	10 Nm (7.4 lbf ft)
---------------------------	----	--------------------

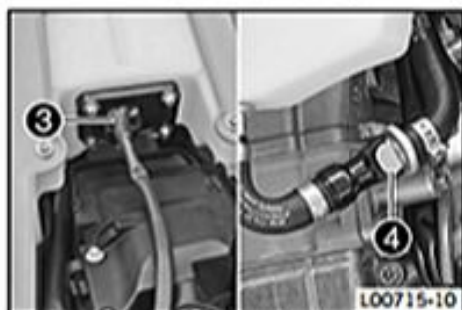

LO0715-10

**(EXC EU/AUS, EXC SIX DAYS, EXC Factory Edition, XC-W)**

- Plug in connector ③ of the fuel pump.
- Remove the wash cap set.
- Thoroughly clean the plug-in connection of the fuel line using compressed air.



**Info**

Under no circumstances should dirt enter into the fuel line. Dirt in the fuel line clogs the injection valve.

- Lubricate the O-ring and connect plug-in connection ④ of the fuel line.

**Info**

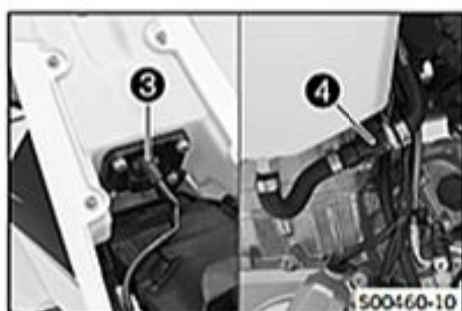
Route the cable and fuel line at a safe distance from the exhaust system.



500460-10

**(500 EXC US)**

- Plug in connector ③ of the fuel pump.
- Remove the wash cap set.
- Thoroughly clean the plug-in connection of the fuel line using compressed air.

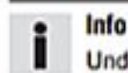
**Info**

Under no circumstances should dirt enter into the fuel line. Dirt in the fuel line clogs the injection valve.

- Lubricate the O-ring and connect plug-in connection ④ of the fuel line.

**Info**

Route the cable and fuel line at a safe distance from the exhaust system.

**Finishing work**

- Mount the seat. (☛ p. 94)

## 12.7 Changing the fuel screen

- Danger**  
**Fire hazard** Fuel is highly flammable.
- Never refuel the vehicle near open flames or burning cigarettes, and always switch off the engine first. Be careful that no fuel is spilled, especially on hot vehicle components. Clean up spilled fuel immediately.
  - The fuel in the fuel tank expands when warm and may emerge if overfilled. Follow the instructions on refueling.

- Warning**  
**Danger of poisoning** Fuel is poisonous and a health hazard.
- Fuel must not come into contact with the skin, eyes, or clothing. Do not breathe in the fuel vapors. If contact occurs with the eyes, rinse with water immediately and contact a physician. Immediately clean contaminated areas on the skin with soap and water. If fuel is swallowed, contact a physician immediately. Change clothing that is contaminated with fuel.

- Warning**  
**Environmental hazard** Improper handling of fuel is a danger to the environment.
- Do not allow fuel to get into the ground water, the ground, or the sewage system.

**(EXC EU/AUS, EXC SIX DAYS, EXC Factory Edition, XC-W)**

- Clean the plug-in connection **1** of the fuel line thoroughly with compressed air.

**i Info**  
 Under no circumstances should dirt enter into the fuel line. Dirt in the fuel line clogs the injection valve.

- Disconnect the plug-in connection of the fuel line.
- Pull fuel screen **2** out of the connecting piece.
- Insert the new fuel screen all the way into the connecting piece.
- Lubricate the O-ring and connect plug-in connection of the fuel line.

**Danger**  
**Danger of poisoning** Exhaust gases are toxic and inhaling them may result in unconsciousness and/or death.

- When running the engine, always make sure there is sufficient ventilation, and do not start or run the engine in an enclosed space without an effective exhaust extraction system.

- Start the engine and check the response.

**(500 EXC US)**

- Clean the plug-in connection **1** of the fuel line thoroughly with compressed air.

**i Info**  
 Under no circumstances should dirt enter into the fuel line. Dirt in the fuel line clogs the injection valve.

- Disconnect the plug-in connection of the fuel line.
- Pull fuel screen **2** out of the connecting piece.
- Insert the new fuel screen all the way into the connecting piece.
- Lubricate the O-ring and connect plug-in connection of the fuel line.

**Danger**  
**Danger of poisoning** Exhaust gases are toxic and inhaling them may result in unconsciousness and/or death.

- When running the engine, always make sure there is sufficient ventilation, and do not start or run the engine in an enclosed space without an effective exhaust extraction system.

- Start the engine and check the response.

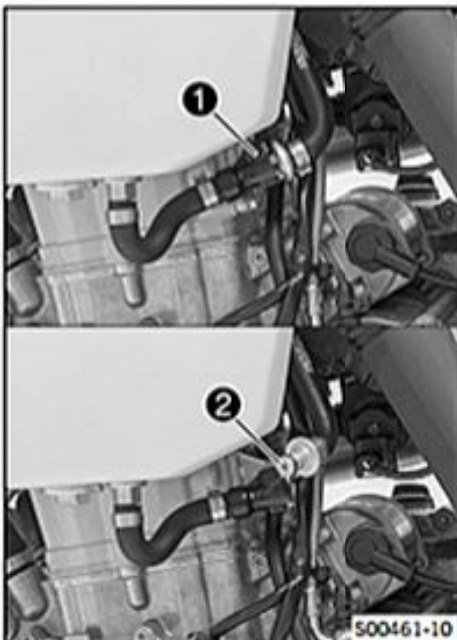

## 12.8 Changing the fuel filter

- Danger**  
**Fire hazard** Fuel is highly flammable.
- Never refuel the vehicle near open flames or burning cigarettes, and always switch off the engine first. Be careful that no fuel is spilt, especially on hot vehicle components. Clean up spilt fuel immediately.
  - The fuel in the fuel tank expands when warm and may emerge if overfilled. Follow the instructions on refueling.

- Warning**  
**Danger of poisoning** Fuel is poisonous and a health hazard.
- Fuel must not come into contact with the skin, eyes, or clothing. Do not breathe in the fuel vapors. If contact occurs with the eyes, rinse with water immediately and contact a physician. Immediately clean contaminated areas on the skin with soap and water. If fuel is swallowed, contact a physician immediately. Change clothing that has been contaminated with fuel. Store fuel properly in a suitable canister and keep away from children.

- Warning**  
**Environmental hazard** Improper handling of fuel is a danger to the environment.
- Do not allow fuel to get into the ground water, the ground, or the sewage system.

### Preparatory work

- Drain the fuel from the fuel tank into a suitable container.
- Remove the seat. (☛ p. 93)
- Remove the fuel tank. (☛ p. 94)

### Main work

- Remove nut ① with the gasket.
- Remove fuel connection ② with the gasket.



- Remove screws ③.
- Pull out the fuel pump.



- Remove hose clamps ④.
- Remove fuel filter ⑤.

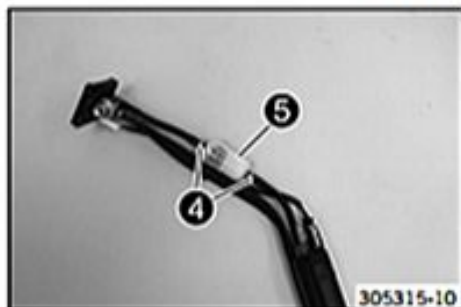



- Press lock ⑥.
- Pull back fuel pump housing ⑦.



- Change fuel screen ⑧.
- Mount the fuel pump housing.

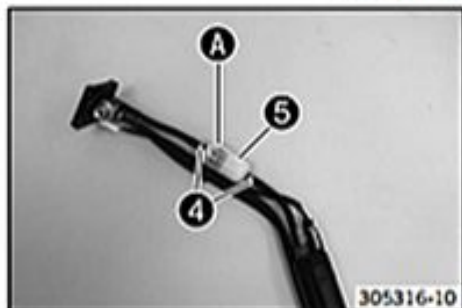

- Mount fuel filter ⑤.
- ✓ Arrow A points away from the fuel pump.
- Mount hose clamps ④.

Hose clamp pliers (60029057000) (☛ p. 316)



- Position the fuel pump.
- Mount fuel connection ② with the gasket but do not tighten yet.

Guideline

Fuel connection on fuel pump	M8	10 Nm (7.4 lbf ft)
------------------------------	----	--------------------

- Mount and tighten nut ① with the gasket.

Guideline

Nut, fuel pump fixation	M12	15 Nm (11.1 lbf ft)
-------------------------	-----	---------------------

- Tighten fuel connection ②.

Guideline

Fuel connection on fuel pump	M8	10 Nm (7.4 lbf ft)
------------------------------	----	--------------------

- Mount and tighten screws ③.

Guideline

Screw, fuel pump	EJOT PT®	3 Nm (2.2 lbf ft)
------------------	----------	-------------------



### Finishing work

- Install the fuel tank. (☛ p. 95)
- Mount the seat. (☛ p. 94)

## 12.9 Changing the fuel pump

**Danger**  
**Fire hazard** Fuel is highly flammable.

- Never refuel the vehicle near open flames or burning cigarettes, and always switch off the engine first. Be careful that no fuel is spilled, especially on hot vehicle components. Clean up spilled fuel immediately.
- The fuel in the fuel tank expands when warm and may emerge if overfilled. Follow the instructions on refueling.

**Warning**  
**Danger of poisoning** Fuel is poisonous and a health hazard.

- Fuel must not come into contact with the skin, eyes, or clothing. Do not breathe in the fuel vapors. If contact occurs with the eyes, rinse with water immediately and contact a physician. Immediately clean contaminated areas on the skin with soap and water. If fuel is swallowed, contact a physician immediately. Change clothing that has been contaminated with fuel. Store fuel properly in a suitable canister and keep away from children.

**Warning**  
**Environmental hazard** Improper handling of fuel is a danger to the environment.

- Do not allow fuel to get into the ground water, the ground, or the sewage system.

### Preparatory work

- Drain the fuel from the fuel tank into a suitable container.
- Remove the seat. (☛ p. 93)
- Remove the fuel tank. (☛ p. 94)

### Main work

- Remove nut ① with the gasket.
- Remove fuel connection ② with the gasket.



- Remove screws ③.
- Pull out the fuel pump.



- Position the fuel pump.
- Mount fuel connection ② with the gasket but do not tighten yet.

#### Guideline

Fuel connection on fuel pump	M8	10 Nm (7.4 lbf ft)
------------------------------	----	--------------------

- Mount and tighten nut ① with the gasket.

#### Guideline

Nut, fuel pump fixation	M12	15 Nm (11.1 lbf ft)
-------------------------	-----	------------------------

- Tighten fuel connection ②.

#### Guideline

Fuel connection on fuel pump	M8	10 Nm (7.4 lbf ft)
------------------------------	----	--------------------



- Mount and tighten screws ③.

**Guideline**

Screw, fuel pump	EJOT PT®	3 Nm (2.2 lbf ft)
------------------	----------	-------------------

## 12.10 Checking the fuel pressure

**Danger**  
**Fire hazard** Fuel is highly flammable.

- Never refuel the vehicle near open flames or burning cigarettes, and always switch off the engine first. Be careful that no fuel is spilt, especially on hot vehicle components. Clean up spilt fuel immediately.
- The fuel in the fuel tank expands when warm and may emerge if overfilled. Follow the instructions on refueling.

**Warning**  
**Danger of poisoning** Fuel is poisonous and a health hazard.

- Fuel must not come into contact with the skin, eyes, or clothing. Do not breathe in the fuel vapors. If contact occurs with the eyes, rinse with water immediately and contact a physician. Immediately clean contaminated areas on the skin with soap and water. If fuel is swallowed, contact a physician immediately. Change clothing that has been contaminated with fuel. Store fuel properly in a suitable canister and keep away from children.

**Condition**

The fuel tank is full.  
 Ensure that the battery voltage does not drop below 12.5 V.  
 The diagnostics tool is disconnected.



- Thoroughly clean the plug-in connection of the fuel line using compressed air.

**i Info**  
 Under no circumstances should dirt enter into the fuel line. Dirt in the fuel line clogs the injection valve.

- Press on the small metal plate and disconnect fuel hose connection ①.

**i Info**  
 Remaining fuel may flow out of the fuel hose.

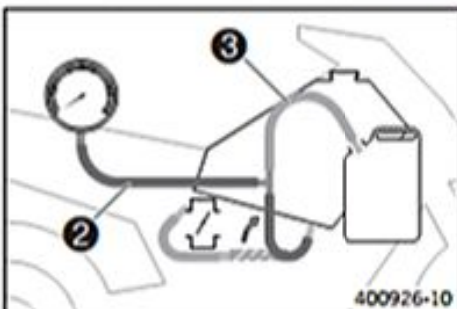

- Mount special tool ②.

Pressure testing tool (61029094000) (☞ p. 317)
--

- Mount special tool ③ with nozzle label 0,60.

Testing hose (61029093000) (☞ p. 317)
---------------------------------------

- Position the hose end in a fuel cannister.

**Guideline**

Minimum size of fuel cannister	10 l (2.6 US gal)
--------------------------------	-------------------

- Connect the diagnostics tool and start it.
- Select the "Function test of fuel pump control" actuator test.

**Guideline**

Maximum duration of the actuator test	3 min
---------------------------------------	-------

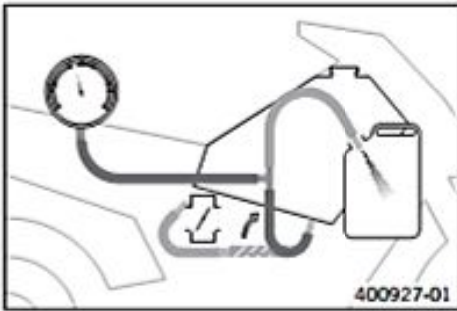

- Check the fuel pressure with the filler cap closed.

Fuel pressure	
When the fuel pump is active	3.35... 3.65 bar (48.6... 52.9 psi)

- If the specification is not reached:
  - Open the filler cap. (☛ p. 93)
  - Check the tank air vent system.

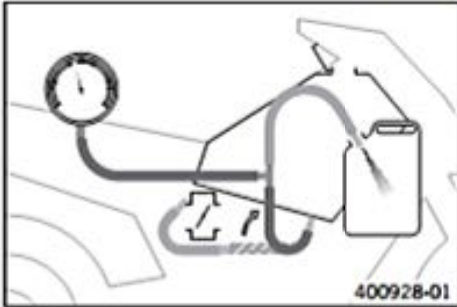

- Check the fuel pressure with the filler cap open.

Fuel pressure	
When the fuel pump is active	3.35... 3.65 bar (48.6... 52.9 psi)

- If the specification is not reached:
  - Check that the fuel line is clear.
  - Change the fuel filter. (☛ p. 98)
  - Change the fuel pump. (☛ p. 100)

- Stop the "Function test of fuel pump control" actuator test by pressing the "Quit" button.
- Remove the special tools.
- Join the fuel hose connection.



## 13.1 Removing the front fender

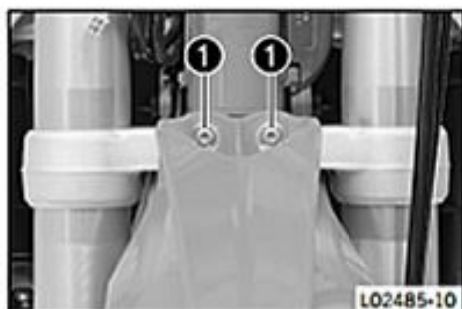

### Preparatory work

- Remove the headlight mask with the headlight. (☛ p. 103)

### Main work

- Remove screws 1.

- Remove screws 2. Remove the front fender.

## 13.2 Installing the front fender

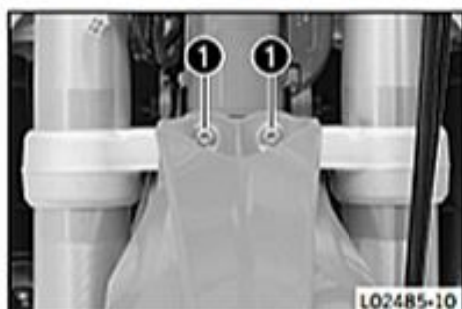

### Main work

- Position the front fender. Mount and tighten screws 1.

#### Guideline

Remaining screws, chassis	M6	10 Nm (7.4 lbf ft)
---------------------------	----	--------------------

- Mount and tighten screws 2.

#### Guideline

Remaining screws, chassis	M6	10 Nm (7.4 lbf ft)
---------------------------	----	--------------------

### Finishing work

- Refit the headlight mask with the headlight. (☛ p. 104)
- Check the headlight setting. (☛ p. 131)

## 13.3 Removing headlight mask with headlight

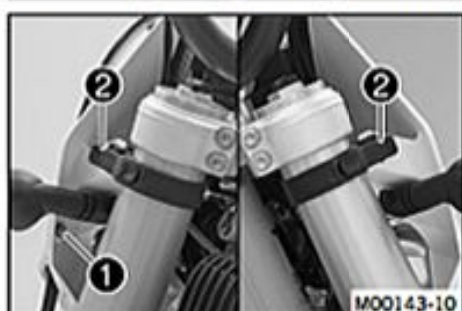

### (EXC EU/AUS, EXC SIX DAYS, EXC Factory Edition, XC-W)

- Switch off all power consumers and switch off the engine.
- Remove screw 1 and take off the clamp.
- Release rubber straps 2. Slide the headlight mask up and swing it forward.



(EXC EU/AUS, EXC SIX DAYS, EXC Factory Edition)

- Detach plug-in connectors ③ and take off the headlight mask with the headlight.



(XC-W)

- Detach plug-in connector ③ and take off the headlight mask with the headlight.

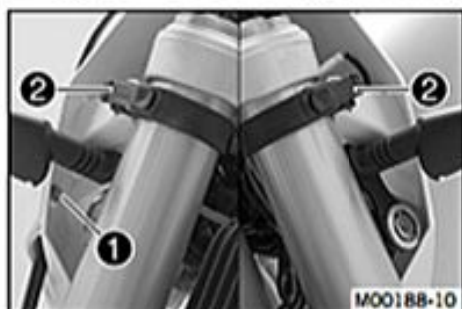

(500 EXC US)

- Switch off all power consumers and switch off the engine.
- Remove screw ① and take off the clamp.
- Release rubber straps ②. Slide the headlight mask up and swing it forward.



- Detach plug-in connectors ③ and take off the headlight mask with the headlight.

## 13.4 Refitting the headlight mask with the headlight



Main work

(EXC EU/AUS, EXC SIX DAYS, EXC Factory Edition)

- Connect plug-in connectors ①.



(XC-W)

- Connect plug-in connector ①.

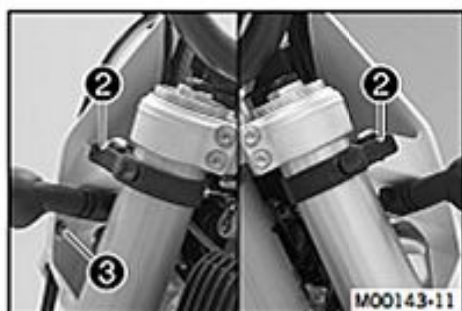

(EXC EU/AUS, EXC SIX DAYS, EXC Factory Edition, XC-W)

- Position the headlight mask and fix it with rubber straps ②.



**Info**

Ensure the holding lugs engage in the fender.

- Position the brake line and wiring harness. Put the clamp on and mount and tighten screw ③.



(500 EXC US)

- Connect plug-in connectors ①.



- Position the headlight mask and fix it with rubber straps ②.



**Info**

Ensure the holding lugs engage in the fender.

- Position the brake line and wiring harness. Put the clamp on and mount and tighten screw ③.

**Finishing work**

- Check the headlight setting. (☛ p. 131)

## 14.1 Checking the tire air pressure

**i** Info

Low tire air pressure leads to abnormal wear and overheating of the tire. Correct tire air pressure ensures optimal riding comfort and maximum tire service life.

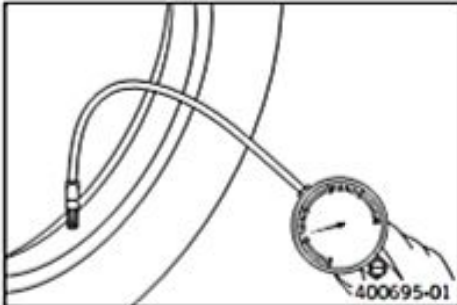

- Remove the protection cap.
- Check the tire air pressure when the tires are cold.

Tire air pressure off road	
Front	1.0 bar (15 psi)
Rear	1.0 bar (15 psi)

Road tire pressure (All EXC models)	
Front	1.5 bar (22 psi)
Rear	1.5 bar (22 psi)

- If the tire air pressure does not meet specifications:
  - Correct the tire air pressure.
- Mount protection cap.

## 14.2 Checking the tire condition

**i** Info

Only mount tires approved and/or recommended by KTM. Other tires could have a negative effect on handling characteristics. The type, condition, and air pressure of the tires all have a significant impact on the handling characteristics of the motorcycle. The tires mounted on the front and rear wheels must have a similar profile. Worn tires have a negative effect on handling characteristics, especially on wet surfaces.

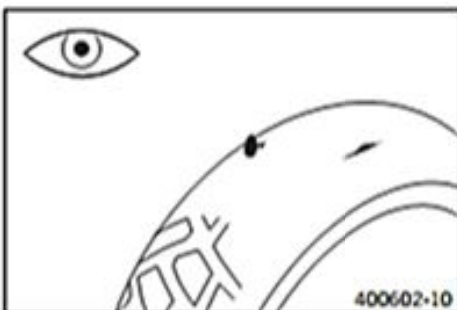

- Check the front and rear tires for cuts, run-in objects, and other damage.
  - If the tire exhibits cuts, run-in objects, or other damage:
    - Change the tire.
- Check the depth of the tread.

**i** Info

Note local national regulations concerning the minimum tread depth.

Minimum tread depth	≥ 2 mm (≥ 0.08 in)
---------------------	--------------------

- If the tread depth is less than the minimum permissible depth:
  - Change the tire.
- Check the tire age.

**i** Info

The tire's date of manufacture is usually part of the tire markings and is indicated by the last four digits of the DOT marking. The first two digits indicate the week of manufacture and the last two digits the year of manufacture.

KTM recommends that the tires be changed after 5 years at the latest, regardless of the actual state of wear.

- If the tire is older than five years:
  - Change the tire.

## 14.3 Checking the brake discs

- Warning**  
**Danger of accidents** Reduced braking efficiency due to worn brake disc(s).  
 - Change the worn brake disc(s) without delay.

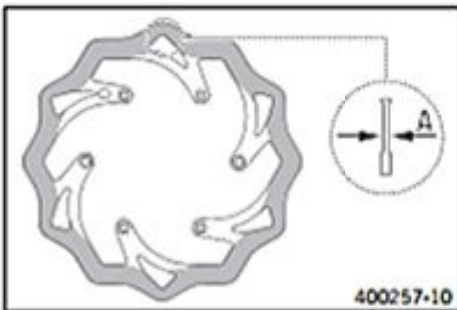

- Check the thickness of the front and rear brake discs at several places on the disk to see if it conforms to measurement **A**.

**Info**  
 Wear reduces the thickness of the brake disc around the area used by the brake linings.

Brake discs - wear limit	
Front	2.5 mm (0.098 in)
Rear	3.5 mm (0.138 in)

- If the brake disc thickness is less than the specified value:
  - Change the brake disc.
- Check the front and rear brake discs for damage, cracking and deformation.
  - If the brake disc shows signs of damage, cracking, or deformation:
    - Change the brake disc.

## 14.4 Checking spoke tension

- Warning**  
**Danger of accidents** Instable handling due to incorrect spoke tension.  
 - Ensure that the spoke tension is correct.

**Info**  
 A loose spoke can cause wheel imbalance, which leads to more loose spokes in a short time. If the spokes are too tight, they can break due to local overload. Check the spoke tension regularly, especially on a new motorcycle.

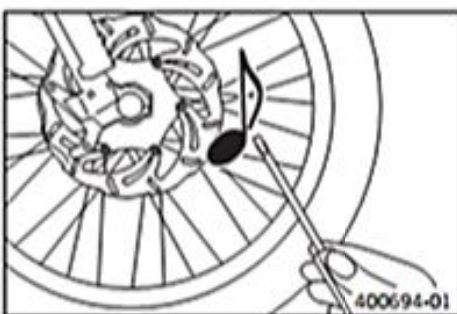

- Tap each spoke with a screwdriver.

**Info**  
 The sound frequency depends on the length and thickness of the spoke. If there are different sound frequencies in spokes with the same length and thickness, this indicates different spoke tensions.

You should hear a high note.

- If the spoke tension varies:
  - Correct the spoke tension.
- Check the spoke torque.

Guideline

Spoke nipple, front wheel	M4.5	6 Nm (4.4 lbf ft)
Spoke nipple, rear wheel	M4.5	6 Nm (4.4 lbf ft)

Torque wrench with various accessories in set (58429094000) (☞ p. 315)

## 14.5 Front wheel

## 14.5.1 Removing the front wheel

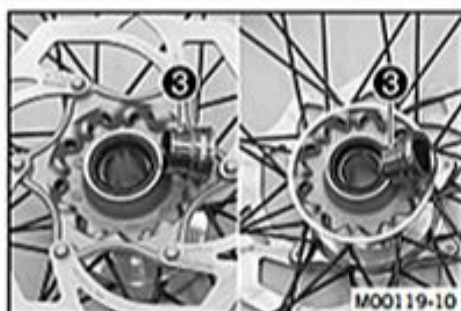

## Preparatory work

- Raise the motorcycle with the lift stand. (☛ p. 11)

## Main work

- Press the brake caliper onto the brake disc by hand in order to push back the brake pistons.



## Info

Make sure when pushing back the brake pistons that you do not press the brake caliper against the spokes.

- Loosen screw 1 by several turns.
- Release screws 2.
- Press on screw 1 to push the wheel spindle out of the axle clamp.
- Remove screw 1.

- Holding the front wheel, withdraw the wheel spindle. Take the front wheel out of the fork.



## Info

Do not pull the hand brake lever when the front wheel is removed. Always lay the wheel down in such a way that the brake disc is not damaged.

- Remove spacers 3.

## 14.5.2 Installing the front wheel



## Warning

**Danger of accidents** Reduced braking efficiency due to oil or grease on the brake discs.

- Always keep the brake discs free of oil and grease, and clean them with brake cleaner when necessary.

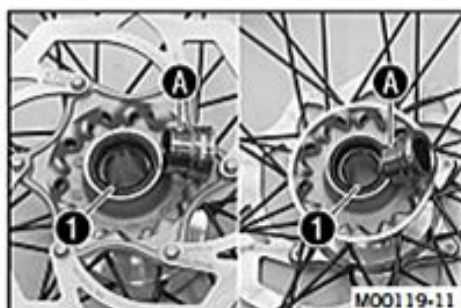

- Check the wheel bearing for damage and wear.
  - If the wheel bearing is damaged or worn:
    - Change the wheel bearing.
- Clean and grease shaft seal rings 1 and bearing surface A of the spacers.

Long-life grease (☛ p. 311)

- Insert the spacers.



- Position the front wheel and insert the wheel spindle.

✓ The brake linings are correctly positioned.

- Mount and tighten screw ②.

#### Guideline

Screw, front wheel spindle	M24x1.5	45 Nm (33.2 lbf ft)
----------------------------	---------	------------------------

- Activate the hand brake lever multiple times until the brake linings are in contact with the brake disc.
- Remove the motorcycle from the lift stand. (☛ p. 11)
- Pull the front wheel brake and push down hard on the fork several times to align the fork legs.
- Fully tighten screw ③.

#### Guideline

Screw, fork stub	M8	15 Nm (11.1 lbf ft)
------------------	----	------------------------

### 14.5.3 Removing the front brake disc

#### Preparatory work

- Raise the motorcycle with the lift stand. (☛ p. 11)
- Remove the front wheel. (☛ p. 108)

#### Main work

- Remove screws ①. Take off the brake disc.



### 14.5.4 Installing the front brake disc



#### Main work

- Clean the contact surface of the brake disc.
- Position the brake disc with the label facing outward. Mount and tighten screws ①.

#### Guideline

Screw, front brake disc	M6	14 Nm (10.3 lbf ft)	Loctite® 243™
-------------------------	----	------------------------	---------------

#### Finishing work

- Install the front wheel. (☛ p. 108)

## 14.6 Rear wheel

### 14.6.1 Removing the rear wheel

#### Preparatory work

- Raise the motorcycle with the lift stand. (☛ p. 11)

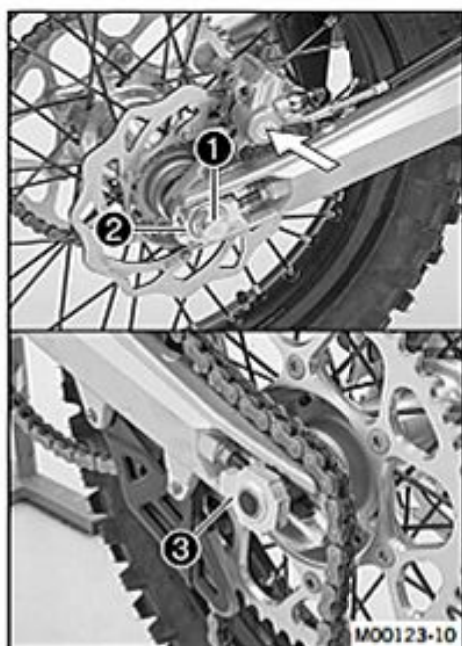
**Main work**

- Press the brake caliper by hand on to the brake disc in order to press back the brake piston.

**i Info**

Make sure when pushing back the brake piston that you do not press the brake caliper against the spokes.

- Remove nut ①.
- Remove chain adjuster ②. Withdraw wheel spindle ③ only enough to allow the rear wheel to be pushed forward.
- Push the rear wheel forward as far as possible. Remove the chain from the rear sprocket.

**i Info**

Cover the components to protect them against damage.

- Holding the rear wheel, withdraw the wheel spindle. Take the rear wheel out of the swingarm.

**i Info**

Do not operate the foot brake when the rear wheel is removed. Always lay the wheel down in such a way that the brake disc is not damaged.

- Remove spacers ④.

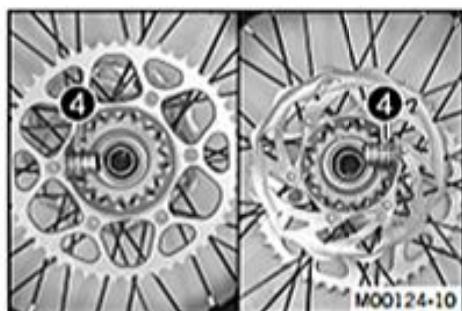
**14.6.2 Installing the rear wheel****Warning**

**Danger of accidents** Reduced braking efficiency due to oil or grease on the brake discs.

- Always keep the brake discs free of oil and grease, and clean them with brake cleaner when necessary.

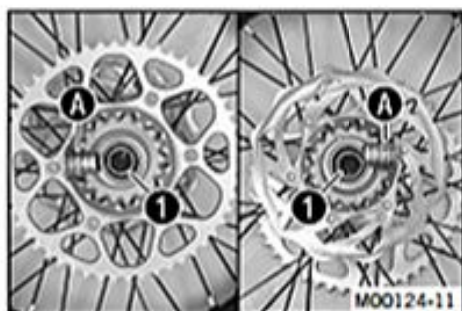
**Main work**

- Check the wheel bearing for damage and wear.
  - If the wheel bearing is damaged or worn:
    - Change the wheel bearing.
- Clean and grease shaft seal rings ① and bearing surface A of the spacers.

Long-life grease (☛ p. 311)

- Insert the spacers.
- Position the rear wheel and insert wheel spindle ②.
  - ✓ The brake linings are correctly positioned.
- Attach the chain.





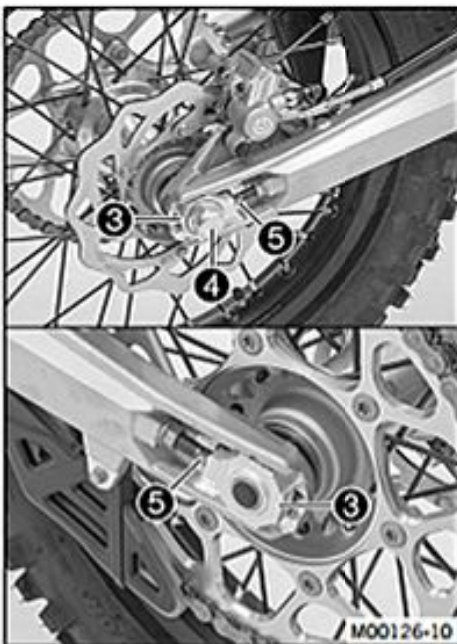

- Position chain adjuster ③. Mount nut ④ but do not tighten it yet.
- Make sure that chain adjusters ③ are fitted correctly on adjusting screws ⑤.
- Check the chain tension. (☞ p. 112)
- Tighten nut ④.

**Guideline**

Nut, rear wheel spindle	M20x1.5	80 Nm (59 lbf ft)
-------------------------	---------	-------------------



**Info**

The wide adjustment range of the chain adjusters (32 mm (1.26 in)) enables different secondary ratios with the same chain length. Chain adjusters ③ can be turned by 180°.

- Operate the foot brake lever repeatedly until the brake linings are in contact with the brake disc and there is a pressure point.

**Finishing work**

- Remove the motorcycle from the lift stand. (☞ p. 11)

### 14.6.3 Removing the rear brake disc

**Preparatory work**

- Raise the motorcycle with the lift stand. (☞ p. 11)
- Remove the rear wheel. (☞ p. 109)

**Main work**

- Remove screws ①. Take off the brake disc.



### 14.6.4 Installing the rear brake disc

**Main work**

- Clean the contact surface of the brake disc.
- Position the brake disc with the label facing outward. Mount and tighten screws ①.

**Guideline**

Screw, rear brake disc	M6	14 Nm (10.3 lbf ft)	Loctite® 243™
------------------------	----	---------------------	---------------



**Finishing work**

- Install the rear wheel. (☞ p. 110)
- Remove the motorcycle from the lift stand. (☞ p. 11)

## 14.6.5 Checking the chain tension

**Warning****Danger of accidents** Danger caused by incorrect chain tension.

- If the chain is too taut, the components of the secondary power transmission (chain, engine sprocket, rear sprocket, bearings in the transmission and in the rear wheel) will be under additional load. In addition to premature wear, this can cause the chain or the countershaft of the transmission to break in extreme cases. If the chain is too loose, however, it may fall off the engine sprocket or rear sprocket and block the rear wheel or damage the engine. Ensure that the chain tension is correct and adjust it if necessary.

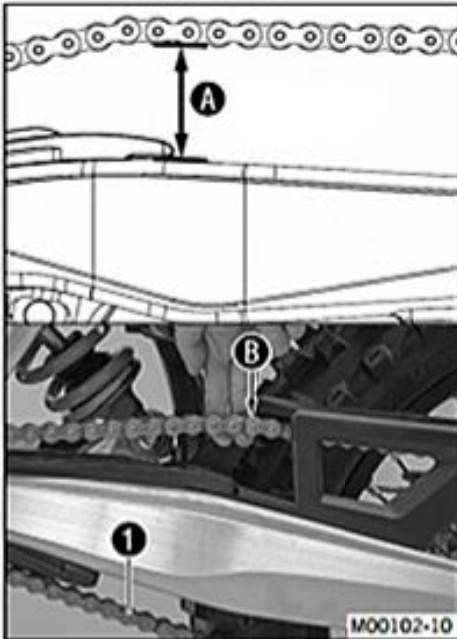
**Preparatory work**

- Raise the motorcycle with the lift stand. (☛ p. 11)

**Main work**

- Pull the chain at the end of the chain sliding component upwards to measure chain tension **A**.

**Info**The lower chain section **1** must be taut.When the chain guard is mounted, it must be possible to pull up the chain at least to the point where it makes contact with chain guard **B**.

Chain wear is not always even, so you should repeat this measurement at different chain positions.

Chain tension	55... 58 mm (2.17... 2.28 in)
---------------	-------------------------------

- If the chain tension does not meet specifications:
  - Adjust the chain tension. (☛ p. 112)

**Finishing work**

- Remove the motorcycle from the lift stand. (☛ p. 11)

## 14.6.6 Adjusting the chain tension

**Warning****Danger of accidents** Danger caused by incorrect chain tension.

- If the chain is too taut, the components of the secondary power transmission (chain, engine sprocket, rear sprocket, bearings in the transmission and in the rear wheel) will be under additional load. In addition to premature wear, this can cause the chain or the countershaft of the transmission to break in extreme cases. If the chain is too loose, however, it may fall off the engine sprocket or rear sprocket and block the rear wheel or damage the engine. Ensure that the chain tension is correct and adjust it if necessary.

**Preparatory work**

- Raise the motorcycle with the lift stand. (☛ p. 11)
- Check the chain tension. (☛ p. 112)

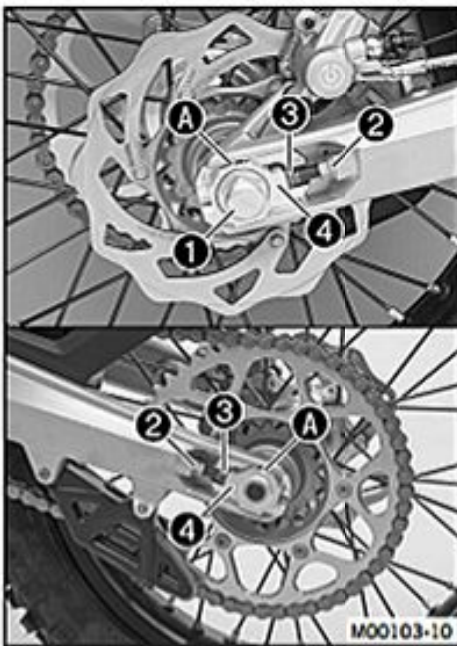

**Main work**

- Loosen nut ①.
- Loosen nuts ②.
- Adjust the chain tension by turning adjusting screws ③ left and right.

**Guideline**

Chain tension	55... 58 mm (2.17... 2.28 in)
Turn adjusting screws ③ on the left and right so that the markings on the left and right chain adjusters are in the same position relative to reference marks A. The rear wheel is then correctly aligned.	

- Tighten nuts ②.
- Make sure that the chain adjusters ④ are fitted correctly on the adjusting screws ③.
- Tighten nut ①.

**Guideline**

Nut, rear wheel spindle	M20x1.5	80 Nm (59 lbf ft)
-------------------------	---------	-------------------



**Info**

The wide adjustment range of the chain adjusters (32 mm (1.26 in)) enables different secondary ratios with the same chain length. Chain adjusters ④ can be turned by 180°.

**Finishing work**

- Remove the motorcycle from the lift stand. (☛ p. 11)

### 14.6.7 Checking the chain, rear sprocket, engine sprocket and chain guide

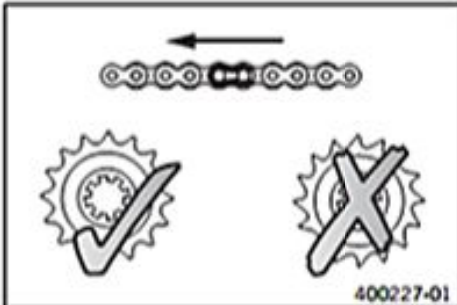

**Preparatory work**

- Raise the motorcycle with the lift stand. (☛ p. 11)

**Main work**

- Shift gear to neutral.
- Check the rear sprocket and engine sprocket for wear.
  - If the rear sprocket or engine sprocket is worn:
    - Change the power set.



**Info**

The engine sprocket, rear sprocket and chain should always be replaced together.

- Pull on the upper part of the chain with the specified weight A.

**Guideline**

Weight of chain wear measurement	10... 15 kg (22... 33 lb.)
----------------------------------	----------------------------

- Measure the distance B of 18 chain links in the lower chain section.



**Info**

Chain wear is not always even, so you should repeat this measurement at different chain positions.

Maximum distance B at the longest chain section	272 mm (10.71 in)
---	-------------------

- If the distance B is greater than the specified measurement:
  - Change the power set.



**Info**

When the chain is replaced, the rear sprocket and engine sprocket should also be changed. New chains wear out faster on old, worn sprockets.

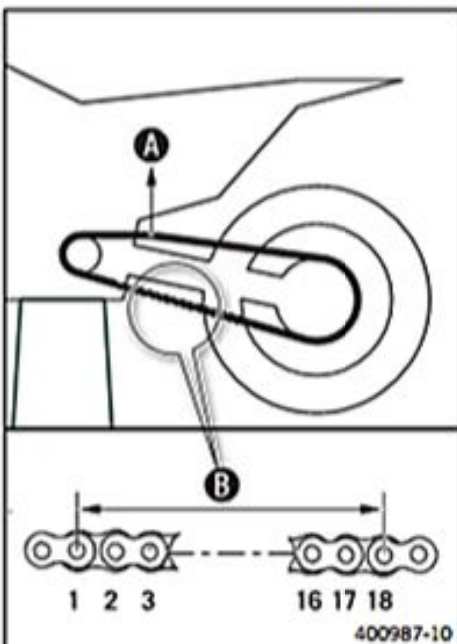

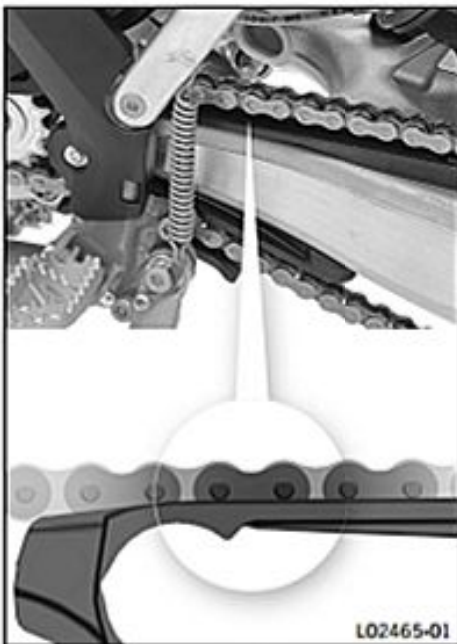

- Check the chain sliding guard for wear.
  - If the bottom edge of the chain bolt is in line with or below the chain sliding guard:
    - Change the chain sliding guard.
- Check that the chain sliding guard is firmly seated.
  - If the chain sliding guard is loose:
    - Tighten the screws on the chain sliding guard.

Guideline

Screw, chain sliding guard	M6	6 Nm (4.4 lbf ft)	Loctite® 243™
----------------------------	----	----------------------	---------------

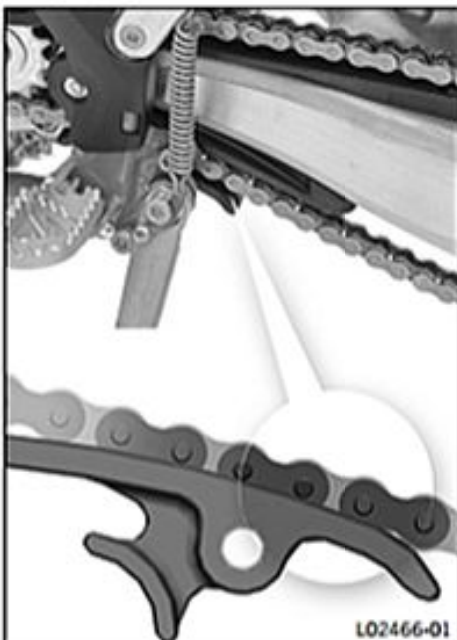

- Check the chain sliding piece for wear.
  - If the bottom edge of the chain bolt is in line with or below the chain sliding piece:
    - Change the chain sliding piece.
- Check that the chain sliding piece is firmly seated.
  - If the chain sliding piece is loose:
    - Tighten the screw of the chain sliding piece.

Guideline

Screw, chain sliding piece	M8	15 Nm (11.1 lbf ft)	
----------------------------	----	------------------------	--

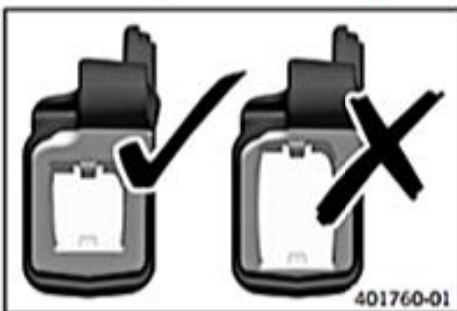

- Check the chain guide for wear.



**Info**

Wear is visible on the front of the chain guide.

- If the light part of the chain guide is worn:
  - Change the chain guide.



- Check that the chain guide is firmly seated.
  - If the chain guide is loose:
    - Tighten the screws on the chain guide.

Guideline

Remaining screws, chassis	M6	10 Nm (7.4 lbf ft)
Remaining nuts, chassis	M6	10 Nm (7.4 lbf ft)

**Finishing work**

- Remove the motorcycle from the lift stand. (☛ p. 11)

## 14.6.8 Checking for chain dirt accumulation

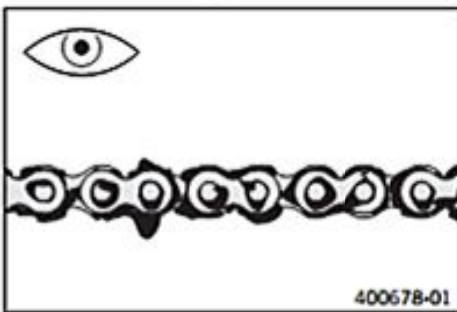

- Check the chain for coarse dirt accumulation.
  - If the chain is very dirty:
    - Clean the chain. (☞ p. 115)

## 14.6.9 Cleaning the chain

**Warning**

**Danger of accidents** Oil or grease on the tires reduces their grip.

- Remove oil and grease with a suitable cleaning material.

**Warning**

**Danger of accidents** Reduced braking efficiency due to oil or grease on the brake discs.

- Always keep the brake discs free of oil and grease, and clean them with brake cleaner when necessary.

**Warning**

**Environmental hazard** Hazardous substances cause environmental damage.

- Oil, grease, filters, fuel, cleaners, brake fluid, etc., should be disposed of as stipulated in applicable regulations.

**Info**

The service life of the chain depends largely on its maintenance.

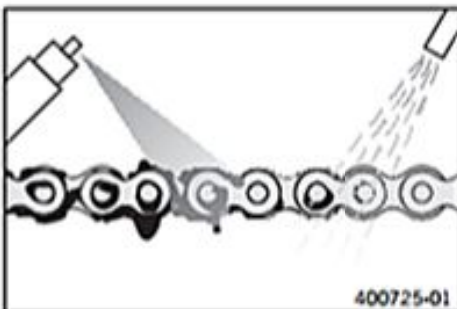
**Preparatory work**

- Raise the motorcycle with the lift stand. (☞ p. 11)

**Main work**

- Clean the chain regularly and then treat with chain spray.

Chain cleaner (☞ p. 311)
Off-road chain spray (☞ p. 312)

**Finishing work**

- Remove the motorcycle from the lift stand. (☞ p. 11)

## 15.1 Removing the main fuse



### Preparatory work

- Switch off all power consumers and switch off the engine.
- Remove the air filter box cover. (☞ p. 90)

### Main work

- Remove the protection cover ①.



### Info

The main fuse ② is located in the starter relay ③ under the filter box cover.

- Remove main fuse ②.

## 15.2 Installing the main fuse



### Warning

**Fire hazard** The electrical system can be overloaded if the wrong fuses are used.

- Use only fuses with the prescribed amperage. Never bypass or repair fuses.

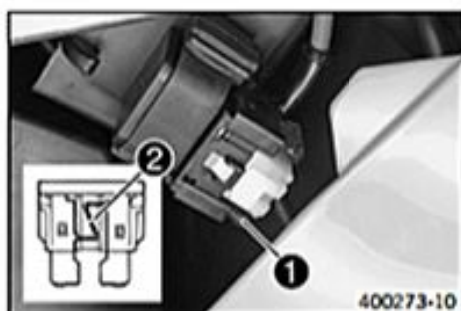

### Main work

- Insert the main fuse.

Fuse (75011088010) (☞ p. 225)



### Info

A reserve fuse ① is located in the starter relay. Replace a burned-out fuse ② only by an equivalent fuse.

- Replace the protection cover.

### Finishing work

- Install the air filter box cover. (☞ p. 90)

## 15.3 Changing the fuses of individual power consumers



### Info

The fuse box containing the fuses of individual power consumers is located under the seat.



### Preparatory work

- Switch off all power consumers and switch off the engine.
- Remove the seat. (☞ p. 93)

### Main work

- Open fuse box cover ①.

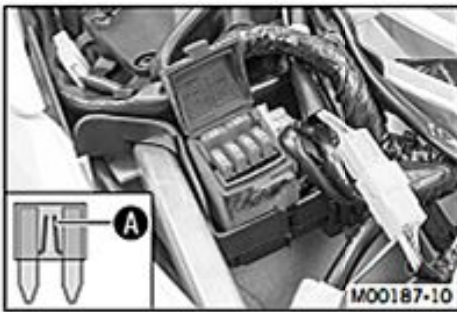

- Remove the defective fuse.

**Guideline**

Fuse 1 - 10 A - EFI control unit

Fuse 2 - 10 A - fuel pump

Fuse 3 - 10 A - high beam, low beam, parking light, tail light, license plate lamp

Fuse 4 - 10 A - horn, brake light, turn signal, radiator fan

**(500 EXC US)**

Fuse 5 - 10 A - ignition

Fuses res - 10 A - spare fuses



**Info**

A defective fuse can be identified by the burned-out fuse wire **A**.



**Warning**

**Fire hazard** The electrical system can be overloaded if the wrong fuses are used.

- Use only fuses with the prescribed amperage. Never bypass or repair fuses.

- Use spare fuses with the correct rating only.

Fuse (75011088010) (☛ p. 225)



**Tip**

Replace the spare fuse in the fuse box so that it is available if needed.

- Check that the power consumer is functioning properly.
- Close the fuse box cover.

**Finishing work**

- Mount the seat. (☛ p. 94)

## 15.4 Removing the battery



**Warning**

**Risk of injury** Battery acid and battery gases cause serious chemical burns.

- Keep batteries out of the reach of children.
- Wear suitable protective clothing and goggles.
- Avoid contact with battery acid and battery gases.
- Keep sparks and open flames away from the battery. Only charge in well-ventilated rooms.
- In the event of skin contact, rinse with large amounts of water. If battery acid gets in the eyes, rinse with water for at least 15 minutes and contact a physician.

**Preparatory work**

- Switch off all power consumers and switch off the engine.
- Remove the seat. (☛ p. 93)
- Remove the air filter box cover. (☛ p. 90)

**Main work**

- Disconnect negative cable **1** from the battery.
- Pull back positive terminal cover **2** and disconnect the positive cable from the battery.
- Detach rubber band **3** at the bottom.
- Lift the battery up and out.



## 15.5 Installing the battery

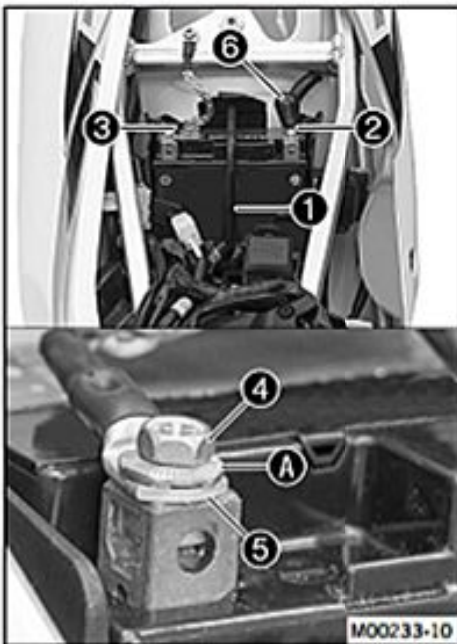

### Main work

- Insert the battery into the battery compartment with the terminals facing forward.

Battery (YTX5L-BS) (☞ p. 225)

- Reconnect rubber band ①.
- Position positive cable ② and mount and tighten the screw.

### Guideline

Screw, battery terminal	M5	2.5 Nm (1.84 lbf ft)
-------------------------	----	-------------------------



### Info

Contact disk A must be mounted between screw ④ and cable lug ⑤ with the claws facing down.

- Slide positive terminal cover ⑥ over the positive terminal.
- Position the negative cable ③ and mount and tighten the screw.

### Guideline

Screw, battery terminal	M5	2.5 Nm (1.84 lbf ft)
-------------------------	----	-------------------------



### Info

Contact disk A must be mounted between screw ④ and cable lug ⑤ with the claws facing down.

### Finishing work

- Install the air filter box cover. (☞ p. 90)
- Mount the seat. (☞ p. 94)

## 15.6 Checking the charging voltage



### Condition

The battery must be fully functional and completely charged.

- Carry out the start procedure. (☞ p. 11)
- **V** Measure the voltage between the specified points.  
Measuring point Plus (+) – Measuring point Ground (-)

### Charging voltage

5,000 rpm	13.5... 15.0 V
-----------	----------------

- If the displayed value is less than the specified value:
  - Check the plug-in connections from the alternator to the voltage regulator.
  - Check the plug-in connectors from the voltage regulator to the wiring harness.
  - Check the stator winding of the alternator. (☞ p. 215)
- If the displayed value is greater than the specified value:
  - Change the voltage regulator.

## 15.7 Checking the quiescent current

### Preparatory work

- Switch off all power consumers and switch off the engine.
- Remove the seat. (☞ p. 93)



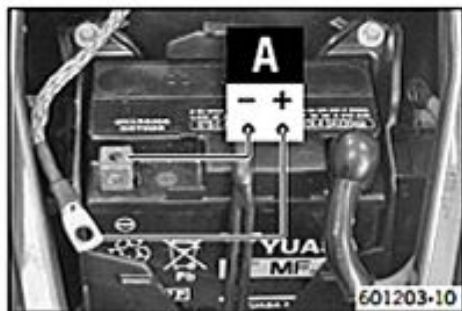

### Main work

- Disconnect the negative cable from the battery.
- Measure the current between battery ground (-) and the negative cable.



### Info

The value of the quiescent current applies only to vehicles in the original state, i.e. without additional power consumers.

Maximum closed-circuit current	< 1.0 mA
--------------------------------	----------

- If the measured value is higher than the specified value:
  - Disconnect the voltage regulator from the wiring harness and perform the measurement again.

## 16.1 Checking the front brake linings

**Warning**  
**Danger of accidents** Reduced braking efficiency caused by worn brake linings.

- Change worn brake linings immediately.

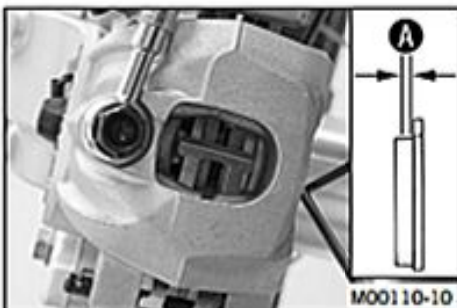

- Check the brake linings for minimum thickness **A**.

Minimum thickness <b>A</b>	$\geq 1 \text{ mm } (\geq 0.04 \text{ in})$
----------------------------	---

- If the minimum thickness is less than specified:
  - Change the front brake linings. (☛ p. 120)
- Check the brake linings for damage and cracking.
  - If damage or cracking is visible:
    - Change the front brake linings. (☛ p. 120)

## 16.2 Changing the front brake linings

**Warning**  
**Danger of accident** Brake system failure.

- Maintenance work and repairs must be carried out professionally.

**Warning**  
**Skin irritation** Brake fluid can cause skin irritation on contact.

- Avoid contact with skin and eyes, and keep out of the reach of children.
- Wear suitable protective clothing and goggles.
- If brake fluid comes into contact with the eyes, flush the eyes thoroughly with water and consult a physician immediately.

**Warning**  
**Danger of accidents** Reduced braking efficiency due to old brake fluid.

- Change the brake fluid of the front and rear brake according to the service schedule.

**Warning**  
**Danger of accidents** Reduced braking efficiency due to oil or grease on the brake discs.

- Always keep the brake discs free of oil and grease, and clean them with brake cleaner when necessary.

**Warning**  
**Danger of accidents** Reduced braking efficiency due to use of non-approved brake linings.

- Brake linings available from accessory suppliers are often not tested and approved for use on KTM vehicles. The construction and friction factor of the brake linings and therefore the brake power can differ considerably from the original KTM brake linings. If brake linings are used that differ from the originals, there is no guarantee that they comply with the original license. The vehicle no longer corresponds to the condition at delivery, and the warranty is no longer valid.

**Warning**  
**Environmental hazard** Hazardous substances cause environmental damage.

- Oil, grease, filters, fuel, cleaners, brake fluid, etc., should be disposed of as stipulated in applicable regulations.

**i Info**  
 Never use DOT 5 brake fluid. It is silicone-based and purple in color. Oil seals and brake lines are not designed for DOT 5 brake fluid.  
 Avoid contact between brake fluid and painted parts. Brake fluid attacks paint!  
 Use only clean brake fluid from a sealed container.



- Move the brake fluid reservoir mounted on the handlebar to a horizontal position.
- Remove screws ①.
- Remove cover ② with membrane ③.
- Press the brake caliper onto the brake disc by hand in order to push back the brake pistons. Ensure that brake fluid does not flow out of the brake fluid reservoir, extracting it by suction if it does.



**Info**

Make sure when pushing back the brake pistons that you do not press the brake caliper against the spokes.

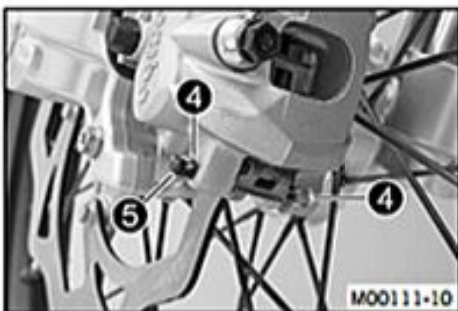

- Remove cotter pins ④, pull out pin ⑤, and remove the brake linings.
- Clean the brake caliper and brake caliper support.

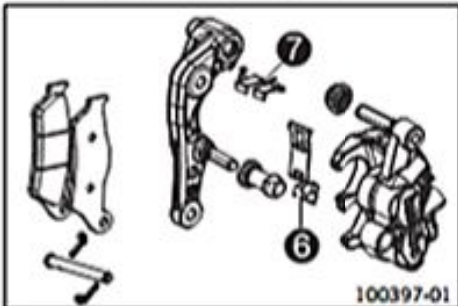

- Check that leaf spring ⑥ in the brake caliper and sliding plate ⑦ in the brake caliper support are seated correctly.



- Insert the new brake linings, insert the pin, and mount the cotter pins.



**Info**

Always change the brake linings in pairs.

- Operate the hand brake lever repeatedly until the brake linings are in contact with the brake disc and there is a pressure point.



- Correct the brake fluid quantity to level ①.

**Guideline**

Level ① (brake fluid level below container rim)	5 mm (0.2 in)
---	---------------

Brake fluid DOT 4 / DOT 5.1 (☞ p. 310)

- Position the cover with the membrane. Mount and tighten the screws.



**Info**

Clean up overflowed or spilt brake fluid immediately with water.

## 16.3 Checking free travel of hand brake lever



### Warning

**Danger of accidents** Brake system failure.

- If there is no free travel on the hand brake lever, pressure builds up on the front brake circuit. The front brake can fail due to overheating. Adjust the free travel on hand brake lever according to specifications.



### (All EXC models)

- Push the hand brake to the handlebar and check free travel **A**.

Free travel of hand brake lever	$\geq 3 \text{ mm } (\geq 0.12 \text{ in})$
---------------------------------	---

- If the free travel does not meet specifications:
  - Adjust the free travel of the hand brake lever. (☞ p. 122)

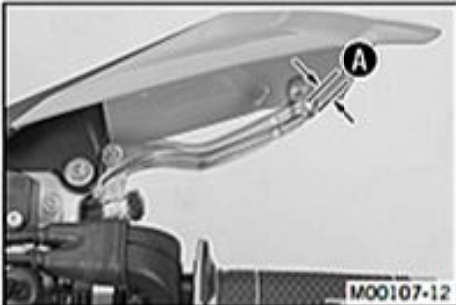

### (XC-W)

- Push the hand brake lever forwards and check free travel **A**.

Free travel of hand brake lever	$\geq 3 \text{ mm } (\geq 0.12 \text{ in})$
---------------------------------	---

- If the free travel does not meet specifications:
  - Adjust the basic position of the hand brake lever. (☞ p. 122)

## 16.4 Adjusting free travel of hand brake lever (All EXC models)

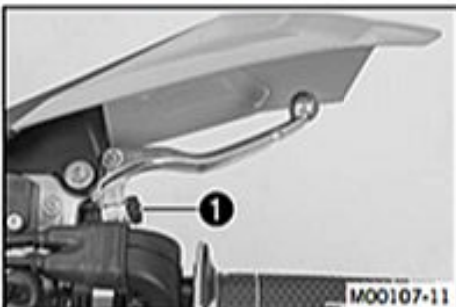

- Check the free travel of the hand brake lever. (☞ p. 122)
- Adjust the free travel of the hand brake lever with adjusting screw **1**.



### Info

Turn the adjusting screw clockwise to reduce free travel. The pressure point moves away from the handlebar.

Turn the adjusting screw counterclockwise to increase free travel. The pressure point moves towards the handlebar.

The range of adjustment is limited.

Turn the adjusting screw by hand only, and do not apply any force.

Do not make any adjustments while riding!

## 16.5 Adjusting the basic position of the hand brake lever (XC-W)



- Check the free travel of the hand brake lever. (☞ p. 122)
- Adjust the basic setting of the hand brake lever to your hand size by turning adjusting screw **1**.



### Info

Turn the adjusting screw clockwise to increase the distance between the hand brake lever and the handlebar.

Turn the adjusting screw counterclockwise to decrease the distance between the hand brake lever and the handlebar.

The range of adjustment is limited.

Turn the adjusting screw by hand only, and do not apply any force.

Do not make any adjustments while riding!

## 16.6 Checking the brake fluid level of the front brake

**Warning****Danger of accidents** Brake system failure.

- If the brake fluid level drops below the specified marking or the specified value, this is an indication that the brake system is leaking or that the brake linings are completely worn down. Check the brake system and do not continue riding.

**Warning****Danger of accidents** Reduced braking efficiency due to old brake fluid.

- Change the brake fluid of the front and rear brake according to the service schedule.

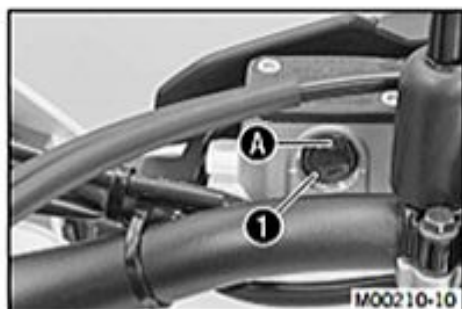

- Move the brake fluid reservoir mounted on the handlebar to a horizontal position.
- Check the brake fluid level in level viewer **1**.
  - If the brake fluid level has dropped below marking **A**:
    - Add front brake fluid. (☛ p. 123)

## 16.7 Adding front brake fluid

**Warning****Danger of accidents** Brake system failure.

- If the brake fluid level drops below the specified marking or the specified value, this is an indication that the brake system is leaking or that the brake linings are completely worn down. Check the brake system and do not continue riding.

**Warning****Skin irritation** Brake fluid can cause skin irritation on contact.

- Avoid contact with skin and eyes, and keep out of the reach of children.
- Wear suitable protective clothing and goggles.
- If brake fluid comes into contact with the eyes, flush the eyes thoroughly with water and consult a physician immediately.

**Warning****Danger of accidents** Reduced braking efficiency due to old brake fluid.

- Change the brake fluid of the front and rear brake according to the service schedule.

**Warning****Environmental hazard** Hazardous substances cause environmental damage.

- Oil, grease, filters, fuel, cleaners, brake fluid, etc., should be disposed of as stipulated in applicable regulations.

**i Info**

Never use DOT 5 brake fluid. It is silicone-based and purple in color. Oil seals and brake lines are not designed for DOT 5 brake fluid.

Avoid contact between brake fluid and painted parts. Brake fluid attacks paint!

Use only clean brake fluid from a sealed container.

**Preparatory work**

- Check the front brake linings. (☛ p. 120)

**Main work**

- Move the brake fluid reservoir mounted on the handlebar to a horizontal position.
- Remove screws **1**.
- Remove cover **2** with membrane **3**.
- Add brake fluid to level **A**.

**Guideline**

Level <b>A</b> (brake fluid level below container rim)	5 mm (0.2 in)
--	---------------

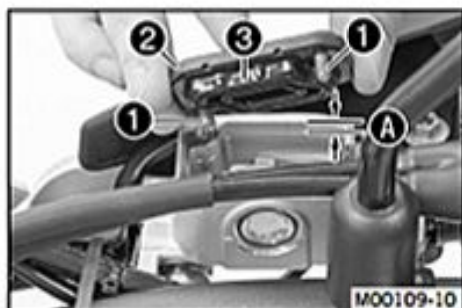

Brake fluid DOT 4 / DOT 5.1 (☞ p. 310)
--

- Position the cover with the membrane. Mount and tighten the screws.

**Info**

Clean up overflowed or spilt brake fluid immediately with water.

## 16.8 Changing the front brake fluid

**Warning**

**Skin irritation** Brake fluid can cause skin irritation on contact.

- Avoid contact with skin and eyes, and keep out of the reach of children.
- Wear suitable protective clothing and goggles.
- If brake fluid comes into contact with the eyes, flush the eyes thoroughly with water and consult a physician immediately.

**Warning**

**Environmental hazard** Hazardous substances cause environmental damage.

- Oil, grease, filters, fuel, cleaners, brake fluid, etc., should be disposed of as stipulated in applicable regulations.

**Info**

Avoid contact between brake fluid and painted parts. Brake fluid attacks paint!

Use only clean brake fluid from a sealed container.



- Move the brake fluid reservoir mounted on the handlebar to a horizontal position.
- Cover the painted parts.
- Remove screws ①.
- Remove cover ② with membrane.
- Draw the old brake fluid out of the brake fluid reservoir using a syringe and fill with fresh brake fluid.

Bleed syringe (50329050000) (☞ p. 314)
--

Brake fluid DOT 4 / DOT 5.1 (☞ p. 310)
--



- Mount bleeder cover ③.

Bleeder cover (00029013005) (☞ p. 313)
--

- Connect the bleeding device.

Bleeding device (00029013100) (☞ p. 313)
--

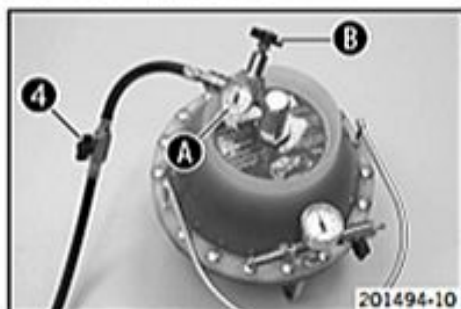

- Open shut-off valve ④.

**Info**

Follow the operating instructions of the bleeding device.

- Ensure that the filling pressure is correctly set at pressure gauge ①. If necessary, adjust the filling pressure at pressure regulator ②.

**Guideline**

Filling pressure	2... 2.5 bar (29... 36 psi)
------------------	-----------------------------

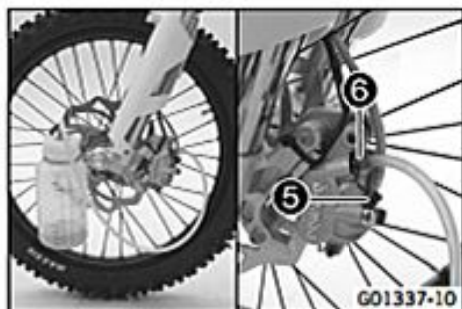

- Pull off protection cap **5** of the brake caliper bleeder screw. Connect the hose of the bleeder bottle.

Bleeding device (00029013100) (☞ p. 313)

- Open bleeder screw **6** by approx. one-half turn.



**Info**

Bleed until fresh brake fluid emerges from the bleeder bottle hose without bubbles.

- Tighten the bleeder screw.
- Close shut-off valve **4**.
- Open the bleeder screw again until no more brake fluid emerges.



**Info**

This prevents overfilling of the brake fluid reservoir.

- Tighten the bleeder screw. Remove the hose of the bleeder bottle. Mount the protection cap.
- Disconnect the bleeding device. Remove the bleeder cover.
- Correct the brake fluid to level **C**.

Guideline

Level <b>C</b>	5 mm (0.2 in)
----------------	---------------

Brake fluid DOT 4 / DOT 5.1 (☞ p. 310)

- Position the cover with the membrane. Mount and tighten the screws.



**Info**

Clean up overflowed or spilt brake fluid immediately with water.

- Check the hand brake lever for a firm pressure point.

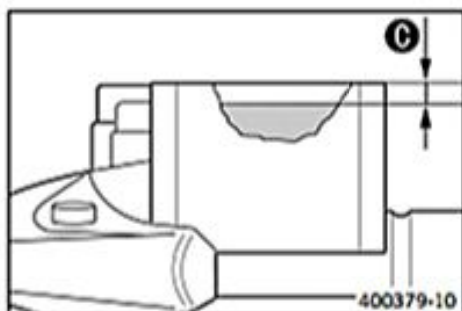

## 16.9 Checking the rear brake linings



**Warning**

**Danger of accidents** Reduced braking efficiency caused by worn brake linings.

- Change worn brake linings immediately.

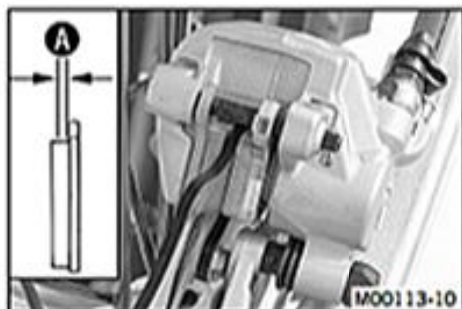

- Check the brake linings for minimum thickness **A**.

Minimum thickness <b>A</b>	≥ 1 mm (≥ 0.04 in)
----------------------------	--------------------

- If the minimum thickness is less than specified:
  - Change the rear brake linings. (☞ p. 125)
- Check the brake linings for damage and cracking.
  - If damage or cracking is visible:
    - Change the rear brake linings. (☞ p. 125)

## 16.10 Changing the rear brake linings



**Warning**

**Danger of accident** Brake system failure.

- Maintenance work and repairs must be carried out professionally.



**Warning**

**Skin irritation** Brake fluid can cause skin irritation on contact.

- Avoid contact with skin and eyes, and keep out of the reach of children.
- Wear suitable protective clothing and goggles.
- If brake fluid comes into contact with the eyes, flush the eyes thoroughly with water and consult a physician immediately.

- Warning**  
**Danger of accidents** Reduced braking efficiency due to old brake fluid.
- Change the brake fluid of the front and rear brake according to the service schedule.
- Warning**  
**Danger of accidents** Reduced braking efficiency due to oil or grease on the brake discs.
- Always keep the brake discs free of oil and grease, and clean them with brake cleaner when necessary.
- Warning**  
**Danger of accidents** Reduced braking efficiency due to use of non-approved brake linings.
- Brake linings available from accessory suppliers are often not tested and approved for use on KTM vehicles. The construction and friction factor of the brake linings and therefore the brake power can differ considerably from the original KTM brake linings. If brake linings are used that differ from the originals, there is no guarantee that they comply with the original license. The vehicle no longer corresponds to the condition at delivery, and the warranty is no longer valid.
- Warning**  
**Environmental hazard** Hazardous substances cause environmental damage.
- Oil, grease, filters, fuel, cleaners, brake fluid, etc., should be disposed of as stipulated in applicable regulations.

- i Info**  
 Never use DOT 5 brake fluid. It is silicone-based and purple in color. Oil seals and brake lines are not designed for DOT 5 brake fluid.  
 Avoid contact between brake fluid and painted parts. Brake fluid attacks paint!  
 Use only clean brake fluid from a sealed container.



- Stand the vehicle upright.
- Remove screw cap ① with membrane ② and the O-ring.
- Press the brake piston back to its basic position and make sure that no brake fluid overflows from the brake fluid reservoir, extracting it if necessary.

- i Info**  
 Make sure when pushing back the brake piston that you do not press the brake caliper against the spokes.

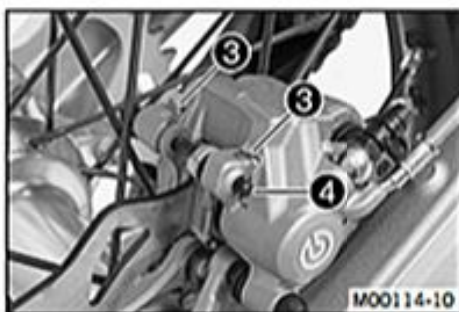

- Remove cotter pins ③, pull out pin ④, and remove the brake linings.
- Clean the brake caliper and brake caliper support.

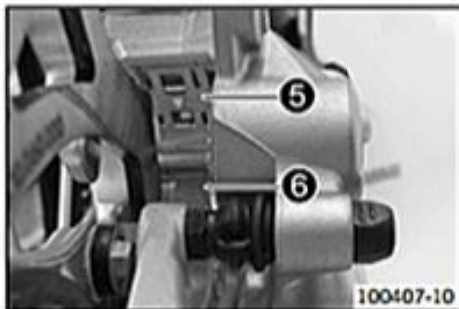

- Check that leaf spring ⑤ in the brake caliper and sliding plate ⑥ in the brake caliper support are seated correctly.





- Insert the new brake linings, insert the pin, and mount the cotter pins.



**Info**

Always change the brake linings in pairs.

- Operate the foot brake lever repeatedly until the brake linings are in contact with the brake disc and there is a pressure point.



- Add brake fluid to level **A**.

Brake fluid DOT 4 / DOT 5.1 (☞ p. 310)
--

- Mount screw cap **1** with membrane **2** and O-ring.



**Info**

Clean up overflowed or spilt brake fluid immediately with water.



## 16.11 Checking the free travel of foot brake lever



**Warning**

**Danger of accidents** Brake system failure.

- If there is no free travel on the foot brake lever, pressure builds up on the rear brake circuit. The rear brake can fail due to overheating. Adjust the free travel on foot brake lever according to specifications.

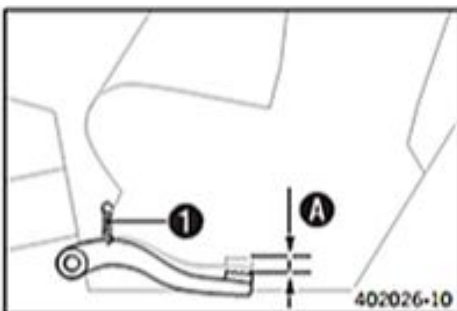

- Disconnect spring **1**.
- Move the foot brake lever back and forth between the end stop and the contact to the foot brake cylinder piston and check free travel **A**.

**Guideline**

Free travel at foot brake lever	3... 5 mm (0.12... 0.2 in)
---------------------------------	----------------------------

- If the free travel does not meet specifications:
  - Adjust the basic position of the foot brake lever. (☞ p. 127)
- Reconnect spring **1**.

## 16.12 Adjusting the basic position of the foot brake lever



**Warning**

**Danger of accidents** Brake system failure.

- If there is no free travel on the foot brake lever, pressure builds up on the rear brake circuit. The rear brake can fail due to overheating. Adjust the free travel on foot brake lever according to specifications.

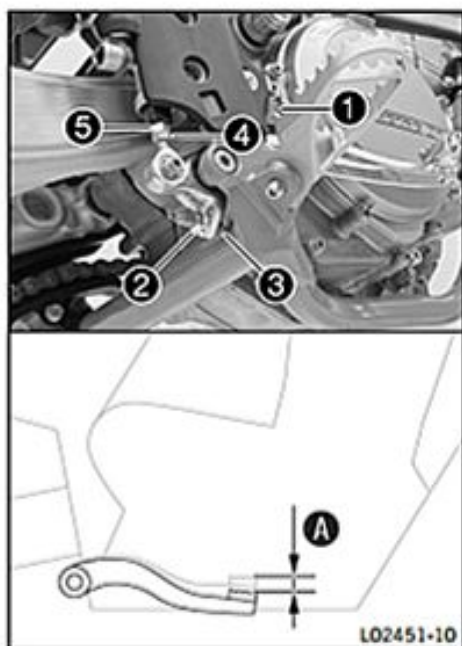

- Disconnect spring ①.
- Loosen nut ④ and, with push rod ⑤, turn it back until you have maximum free travel.
- To adjust the basic position of the foot brake lever individually, loosen nut ② and turn screw ③ accordingly.

**Info**

The range of adjustment is limited.

- Turn push rod ⑤ accordingly until you have free travel A. If necessary, adjust the basic position of the foot brake lever.

**Guideline**

Free travel at foot brake lever	3... 5 mm (0.12... 0.2 in)
---------------------------------	----------------------------

- Hold screw ③ and tighten nut ②.

**Guideline**

Nut, foot brake lever stop	M8	20 Nm (14.8 lbf ft)
----------------------------	----	------------------------

- Hold push rod ⑤ and tighten nut ④.

**Guideline**

Remaining nuts, chassis	M6	10 Nm (7.4 lbf ft)
-------------------------	----	--------------------

- Reconnect spring ①.

### 16.13 Checking the rear brake fluid level

**Warning**

**Danger of accidents** Brake system failure.

- If the brake fluid level drops below the specified marking or the specified value, this is an indication that the brake system is leaking or that the brake linings are completely worn down. Check the brake system and do not continue riding.

**Warning**

**Danger of accidents** Reduced braking efficiency due to old brake fluid.

- Change the brake fluid of the front and rear brake according to the service schedule.



- Stand the vehicle upright.
- Check the brake fluid level in level viewer ①.
  - If the brake fluid level has dropped below marking A:
    - Add rear brake fluid. (☛ p. 128)

### 16.14 Adding rear brake fluid

**Warning**

**Danger of accidents** Brake system failure.

- If the brake fluid level drops below the specified marking or the specified value, this is an indication that the brake system is leaking or that the brake linings are completely worn down. Check the brake system and do not continue riding.

**Warning**

**Skin irritation** Brake fluid can cause skin irritation on contact.

- Avoid contact with skin and eyes, and keep out of the reach of children.
- Wear suitable protective clothing and goggles.
- If brake fluid comes into contact with the eyes, flush the eyes thoroughly with water and consult a physician immediately.



**Warning**

**Danger of accidents** Reduced braking efficiency due to old brake fluid.

- Change the brake fluid of the front and rear brake according to the service schedule.



**Warning**

**Environmental hazard** Hazardous substances cause environmental damage.

- Oil, grease, filters, fuel, cleaners, brake fluid, etc., should be disposed of as stipulated in applicable regulations.



**Info**

Never use DOT 5 brake fluid. It is silicone-based and purple in color. Oil seals and brake lines are not designed for DOT 5 brake fluid.

Avoid contact between brake fluid and painted parts. Brake fluid attacks paint!

Use only clean brake fluid from a sealed container.



**Preparatory work**

- Check the rear brake linings. (☞ p. 125)

**Main work**

- Stand the vehicle upright.
- Remove screw cap 1 with membrane 2 and the O-ring.
- Add brake fluid to level A.

Brake fluid DOT 4 / DOT 5.1 (☞ p. 310)

- Mount the screw cap with the membrane and the O-ring.



**Info**

Clean up overflowed or spilt brake fluid immediately with water.

## 16.15 Changing the rear brake fluid



**Warning**

**Skin irritation** Brake fluid can cause skin irritation on contact.

- Avoid contact with skin and eyes, and keep out of the reach of children.
- Wear suitable protective clothing and goggles.
- If brake fluid comes into contact with the eyes, flush the eyes thoroughly with water and consult a physician immediately.



**Warning**

**Environmental hazard** Hazardous substances cause environmental damage.

- Oil, grease, filters, fuel, cleaners, brake fluid, etc., should be disposed of as stipulated in applicable regulations.



**Info**

Avoid contact between brake fluid and painted parts. Brake fluid attacks paint!

Use only clean brake fluid from a sealed container.



- Cover the painted parts.
- Remove screw cap ① with membrane and the O-ring.
- Draw the old brake fluid out of the brake fluid reservoir using a syringe and fill with fresh brake fluid.

Bleed syringe (50329050000) (☞ p. 314)

Brake fluid DOT 4 / DOT 5.1 (☞ p. 310)



- Mount bleeder cover ②.

Bleeder cover (00029013006) (☞ p. 313)

- Connect the bleeding device.

Bleeding device (00029013100) (☞ p. 313)

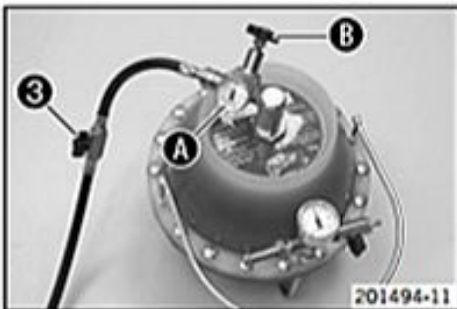

- Open shut-off valve ③.



**Info**

Follow the operating instructions of the bleeding device.

- Ensure that the filling pressure is correctly set at pressure gauge A. If necessary, adjust the filling pressure at pressure regulator B.

**Guideline**

Filling pressure	2... 2.5 bar (29... 36 psi)
------------------	-----------------------------

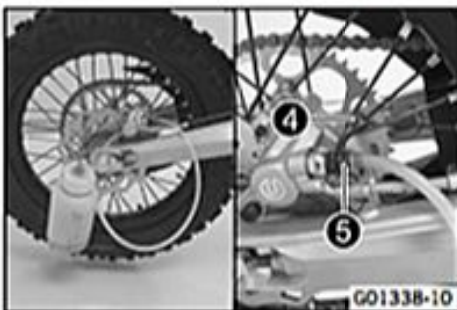

- Pull off protection cap ④ of the bleeder screw. Connect the hose of the bleeder bottle.

Bleeding device (00029013100) (☞ p. 313)

- Open bleeder screw ⑤ by approx. one-half turn.



**Info**

Bleed until new brake fluid emerges from the bleeder bottle hose without bubbles.

- Tighten the bleeder screw.
- Close shut-off valve ③.
- Open the bleeder screw again until no more brake fluid emerges.



**Info**

This prevents overfilling of the brake fluid reservoir.

- Tighten the bleeder screw. Remove the hose of the bleeder bottle. Mount the protection cap.
- Disconnect the bleeding device. Remove the bleeder cover.
- Stand the vehicle upright.
- Correct the brake fluid to marking C.

Brake fluid DOT 4 / DOT 5.1 (☞ p. 310)

- Fit and tighten plug with oil screen and O-ring.



**Info**

Clean up overflowed or spilt brake fluid immediately with water.



- Check the foot brake lever for a firm pressure point.

## 17.1 Checking the headlight setting

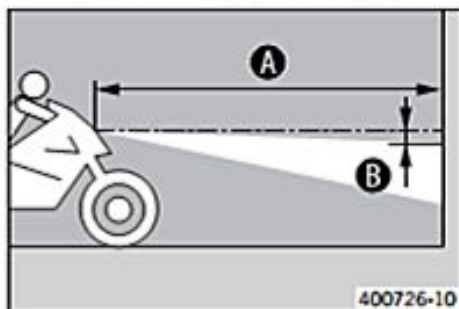

400726-10

- Position the vehicle upright on a horizontal surface in front of a light wall and make a mark at the height of the center of the low beam headlight.

- Make another mark a distance **B** under the first mark.

Guideline

Distance <b>B</b>	5 cm (2 in)
-------------------	-------------

- Position the vehicle vertically a distance **A** away from the wall.

Guideline

Distance <b>A</b>	5 m (16 ft)
-------------------	-------------

- The rider now sits down on the motorcycle.
- Switch on the low beam.
- Check the headlight setting.

The boundary between light and dark must be exactly on the lower mark for a motorcycle with driver.

- If the light-dark border does not meet specifications:
  - Adjust the headlight range. (☛ p. 131)

## 17.2 Adjusting the headlight range



LO2459-10

### Preparatory work

- Check the headlight setting. (☛ p. 131)

### Main work

(EXC EU/AUS, EXC SIX DAYS, EXC Factory Edition, XC-W)

- Loosen screw **1**.
- Adjust the headlight range by pivoting the headlight.

Guideline

The boundary between light and dark must be exactly on the lower mark for a motorcycle with driver (instructions on how to apply the mark: Checking the headlight setting).



### Info

A change in weight on the vehicle may require a correction of the headlight range.

- Tighten screw **1**.

(500 EXC US)

- Loosen screw **1**.
- Adjust the headlight range by pivoting the headlight.

Guideline

The boundary between light and dark must be exactly on the lower mark for a motorcycle with driver (instructions on how to apply the mark: Checking the headlight setting).



### Info

A change in weight on the vehicle may require a correction of the headlight range.

- Tighten screw **1**.



MO0190-10

## 17.3 Speedometer overview

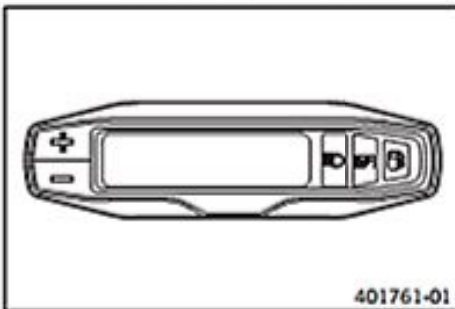

- Press the button to control different functions.
- Press the button to control different functions.

### **i** Info

When the vehicle is delivered, only the **SPEED/H** and **SPEED/000** display modes are activated.

## 17.4 Activation and test

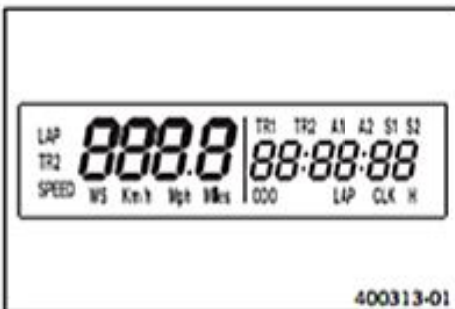

### Activating the speedometer

The speedometer is activated when one of the buttons is pressed or an impulse comes from the wheel speed sensor.

### Display test

To enable you to check that the display is functioning properly, all display segments light up briefly.



### WS (wheel size)

After the display function check, the wheel size **WS** is displayed briefly.

### **i** Info

The number 2205 equals the circumference of the 21" front wheel with standard tires.

The display then changes to the last selected mode.

## 17.5 Setting kilometers or miles

### **i** Info

If you change the unit, the value **000** is retained and converted accordingly. The values **TR1**, **TR2**, **A1**, **A2** and **S1** are cleared when the unit of measure is changed.

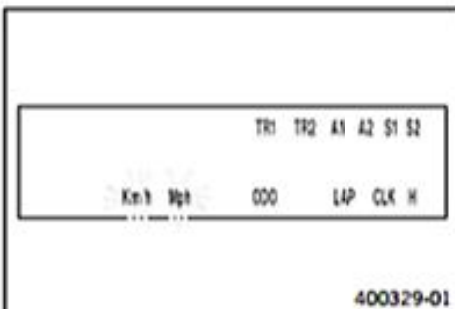

### Condition

The motorcycle is stationary.

- Repeatedly press the button briefly until **H** appears at the bottom right of the display.
- Press the button for 2-3 seconds.
  - ✓ The Setup menu is displayed and the active functions are shown.
- Repeatedly press the button briefly until **Km/h/Mph** flashes.

### Setting the Km/h

- Press the button .

### Setting the Mph

- Press the button .
- Wait 3-5 seconds
  - ✓ The settings are stored.

### **i** Info

If no button is pressed for 10 -12 seconds, or if an impulse comes from the wheel speed sensor, the settings are automatically saved and the setup menu is closed.

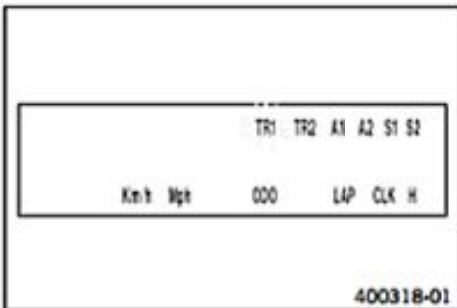

## 17.6 Setting the speedometer functions

**Info**  
When the vehicle is delivered, only the **SPEED/H** and **SPEED/ODO** display modes are activated.



**Condition**

The motorcycle is stationary.

- Repeatedly press the button  briefly until **H** appears at the bottom right of the display.
- Press the button  for 2-3 seconds.
- ✓ The Setup menu is displayed and the active functions are shown.

**Info**  
If no button is pressed for 10-12 seconds, the settings are automatically saved.  
If no button is pressed for 20 seconds, or if an impulse comes from the wheel speed sensor, the settings are automatically saved and the setup menu is closed.

- Repeatedly press the button  briefly until the desired function flashes.
- ✓ The selected function flashes.

**Activating the function**

- Press the button .
- ✓ The symbol continues to appear in the display and the next function appears.

**Deactivating a function**





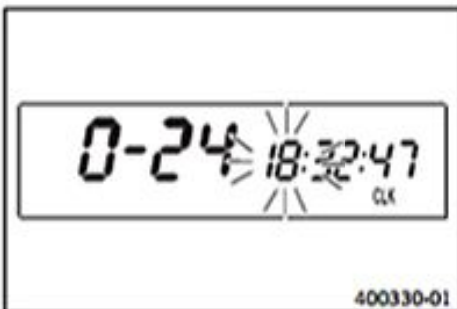

- Press the button .
- ✓ The symbol disappears in the display and the next function appears.

## 17.7 Setting the clock



**Condition**

The motorcycle is stationary.

- Repeatedly press the button  briefly until **CLK** appears at the bottom right of the display.
- Press the button  for 2-3 seconds.
- ✓ The hour display flashes.
- Set the hour display with the button  and/or button .
- Wait 3-5 seconds
- ✓ The next segment of the display flashes and can be set.
- You can set the following segments in the same way as the hours by pressing the button  and the button .

**Info**  
The seconds can only be set to zero.  
If no button is pressed for 15 -20 seconds, or if an impulse comes from the wheel speed sensor, the settings are automatically saved and the setup menu is closed.

## 17.8 Activating the additional functions

**Danger**  
**Voiding of the government approval for road use and the insurance coverage** The vehicle is only authorized for operation on public roads in the homologated version.

- If the vehicle is modified in any way, it may only be used on designated tracks away from public roads. Advise the vehicle owner and rider of this.
- If you undertake any modifications, please insist on receiving a signed workshop order from your customer in which you inform the customer in writing that these modifications are performed at the customer's own risk and that the vehicle will no longer be approved for use on public roads once modified.

**Preparatory work**

- Remove the headlight mask with the headlight. (◀ p. 103)



**Main work**

- Expose connector CZ ①.



- Sever the black/brown cable ②.
- Insulate both cable ends.

**Finishing work**

- Refit the headlight mask with the headlight. (☛ p. 104)
- Check the headlight setting. (☛ p. 131)

## 17.9 Setting the wheel circumference



**Condition**

The motorcycle is stationary.

**Preparatory work**

- Remove the headlight mask with the headlight. (☛ p. 103)
- Activate the additional functions. (☛ p. 133)

**Main work**

- Repeatedly press the button  briefly until H appears at the bottom right of the display.
- Press the button  for 2-3 seconds.
- When WS flashes, press the  button briefly.



**Info**

The wheel circumference is displayed in millimeters.

**Enlarging the wheel circumference**

- Press the button .

**Reducing the wheel circumference**

- Press the button .



**Info**

If no button is pressed for 20 seconds, or if no impulse comes from the wheel speed sensor, the settings are automatically saved and the Setup menu is closed.

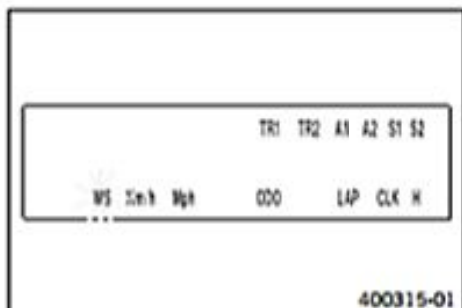

## 17.10 Viewing the lap time



**Info**





This function can only be opened if lap times have actually been timed.

**Condition**

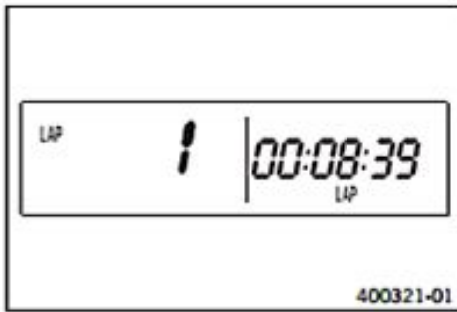
The motorcycle is stationary.





- Repeatedly press the button  briefly until **LAP** appears at the bottom right of the display.
- Briefly press the button .
  - ✓ **LAP 1** appears on the left side of the display.
- The laps 1–10 can be viewed with the button .
- Press and hold the button  for 3-5 seconds.
  - ✓ The lap times are deleted.
- Briefly press the button .
  - ✓ Next display mode



### Info

When an impulse is received from the wheel speed sensor, the left side of the display changes back to the **SPEED** mode.

## 18.1 Removing the engine

## Preparatory work

- Raise the motorcycle with the lift stand. (☞ p. 11)
- Drain the coolant. (☞ p. 208)
- Remove the seat. (☞ p. 93)
- Remove the fuel tank. (☞ p. 94)
- Remove the main silencer. (☞ p. 88)

## Main work

- Disconnect negative cable ❶ of the battery.



- Remove screw ❷.
- Remove the cable binder(s).
- Remove the frame protector.

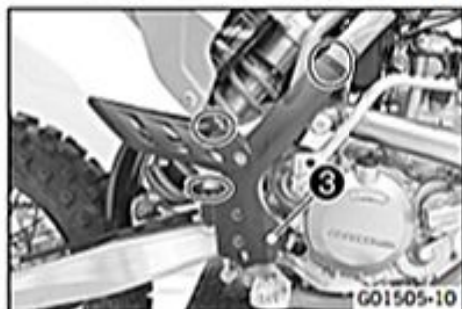

- Remove screw ❸.
- Remove the cable binder(s).
- Remove the frame protector.



## Info

Pay attention to the holding lugs.



- Loosen hose clip ❹.



- Push back hose clamp ❺.
- Pull off the vent hose.



- Remove screw ⑥.
- Loosen screw ⑦.
- Repeat the operation on the opposite side.
- Swing up the subframe and secure it.



- Remove screw ⑧.
- Pivot the shock absorber toward the rear and twist it slightly.



- Disconnect the plug-in connector of the lambda sensor.
- Expose the cable.



- Remove springs ⑨.

Spring hooks (50305017000) (☛ p. 314)



- Remove screw ⑩.
- Remove the manifold.



- Pull back the protection cap.
- Remove nut 11.



- Remove screw 12.



- Remove screw 13.
- Take off the engine sprocket cover.

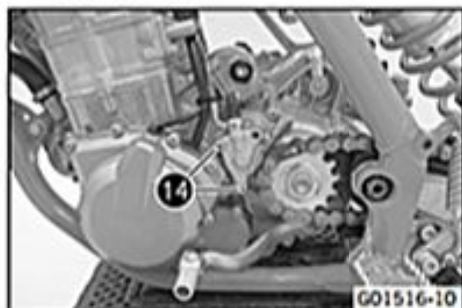

- Remove screws 14.
- Remove the cable binder(s).
- Take off the clutch slave cylinder and hang it to the side.

**Info**

Do not kink the clutch line.  
Do not activate the clutch lever if the clutch slave cylinder has been removed.



- Remove the connecting link of the chain.
- Take off the chain.



- Remove screw 15.
- Take off the shift lever.



- Disconnect plug-in connector 16.
- Disconnect plug-in connector 17.



- Loosen hose clips 18.
- Pull off the radiator hoses.



- Loosen hose clip 19.
- Take off the radiator hose.

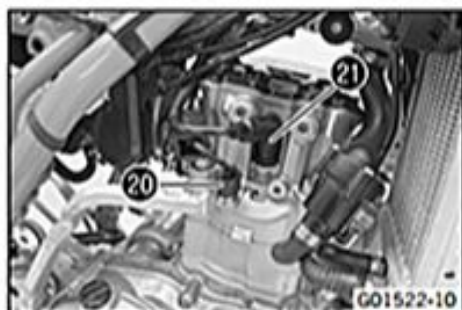

- Pull back the protection cap.
- Unplug connector 20.
- Pull off spark plug connector 21.



- Loosen hose clip 22.
- Pull the throttle valve body out of the intake flange toward the rear and hang it to one side.



- Remove screw connections 23.
- Remove the engine braces.



- Remove spring 24.



- Remove nut 25.
- Remove the swingarm pivot.
- Pull the swingarm slightly toward the rear.



- Remove screws 26.



- Lift out the engine from the side.

**i** Info

You should have an assistant for this step.  
Make sure that the engine is sufficiently secured against falling over.  
Protect the frame and attachments from damage.

## 18.2 Installing the engine

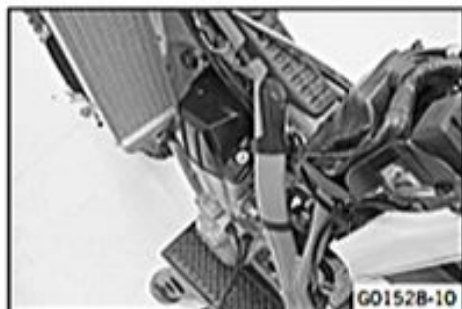

**Main work**

- Position the engine in the frame.

**i** Info

The help of an assistant is useful in this step.  
Make sure that the engine is sufficiently secured against falling over.  
Protect the frame and attachments against damage.



- Mount screws 1 but do not tighten yet.

**Guideline**

Engine attachment bolt	M10	60 Nm (44.3 lbf ft)
------------------------	-----	------------------------



- Position the swingarm.
- Insert the swingarm pivot.
- Mount and tighten nut **2**.

Guideline

Nut, swingarm pivot	M16x1.5	100 Nm (73.8 lbf ft)
---------------------	---------	-------------------------

- Tighten screws **1**.

Guideline

Engine attachment bolt	M10	60 Nm (44.3 lbf ft)
------------------------	-----	------------------------

- Mount spring **3**.



- Position the engine braces.
- Mount and tighten fitting **4**.

Guideline

Screw, engine brace	M8	33 Nm (24.3 lbf ft)	Loctite® 2701™
---------------------	----	------------------------	----------------



- Position the throttle valve body.
- Tighten hose clip **5**.



- Plug in connector **6**.
- Position the protection cap.
- Mount spark plug connector **7**.



- Mount the radiator hose.
- Position and tighten hose clips **8**.





- Mount the radiator hoses.
- Position and tighten hose clips **9**.



- Position the shift lever.
- Mount and tighten screw **10**.

## Guideline

Screw, shift lever	M6	14 Nm (10.3 lbf ft)	Loctite® 243™
--------------------	----	------------------------	---------------

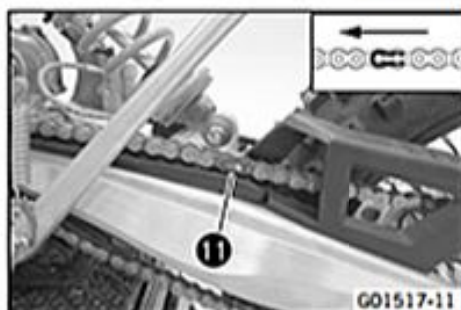

- Mount the chain.
- Connect the chain with connecting link **11**.



- Connect plug-in connector **12**.
- Connect plug-in connector **13**.
- Route the cable loosely and secure with a cable binder.

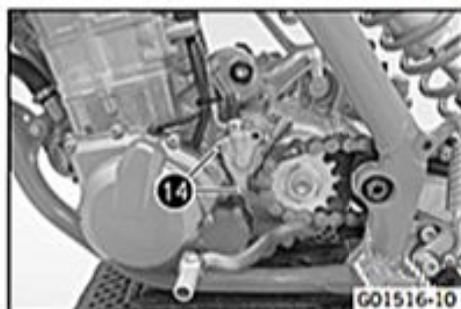

- Position the clutch slave cylinder with the gasket.
- Mount and tighten screws **14**.

## Guideline

Screw, clutch slave cylinder	M6	10 Nm (7.4 lbf ft)	
------------------------------	----	--------------------	--



- Position the engine sprocket cover.
- Mount and tighten screw **15**.

## Guideline

Screw, clutch slave cylinder	M6	10 Nm (7.4 lbf ft)	
------------------------------	----	--------------------	--





- Mount and tighten screw 16.

## Guideline

Remaining screws, chassis	M8	25 Nm (18.4 lbf ft)
---------------------------	----	------------------------



- Position the positive cable on the starter motor.
- Mount and tighten nut 17.

## Guideline

Remaining nuts, chassis	M6	10 Nm (7.4 lbf ft)
-------------------------	----	--------------------

- Mount protection cap.



- Feed in the manifold.
- Mount screw 18 but do not tighten yet.

## Guideline

Remaining screws, chassis	M8	25 Nm (18.4 lbf ft)
---------------------------	----	------------------------



- Mount springs 19.

Spring hooks (50305017000) (☛ p. 314)
---------------------------------------

- Tighten screw 18.

## Guideline

Remaining screws, chassis	M8	25 Nm (18.4 lbf ft)
---------------------------	----	------------------------



- Connect the plug-in connector of the lambda sensor.
- Route the cable loosely and secure with a cable binder.

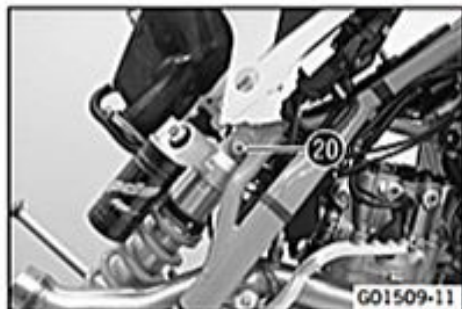

- Position the shock absorber.
- Mount and tighten screw 20.

## Guideline

Screw, top shock absorber	M12	80 Nm (59 lbf ft)	Loctite® 2701™
---------------------------	-----	----------------------	----------------



- Position the subframe.

**Info**

Watch out for the intake flange.

- Mount and tighten screw 21.

## Guideline

Screw, subframe	M8	35 Nm (25.8 lbf ft)	Loctite® 2701™
-----------------	----	------------------------	----------------

- Remove screw 22.
- Mount and tighten screw 22.

## Guideline

Screw, subframe	M8	35 Nm (25.8 lbf ft)	Loctite® 2701™
-----------------	----	------------------------	----------------

- Repeat the operation on the opposite side.



G01508-11



G01507-11

- Position the vent hose and mount hose clamp 23.



G01506-11

- Position and tighten hose clip 24.



G01505-11

- Position the frame protector.

**Info**

Pay attention to the holding lugs.

- Mount and tighten screw 25.

## Guideline

Screw, frame protector	M5	3 Nm (2.2 lbf ft)
------------------------	----	-------------------

- Mount cable binder.
- Position the frame protector.
- Mount and tighten screw 26.

## Guideline

Screw, frame protector	M5	3 Nm (2.2 lbf ft)
------------------------	----	-------------------

- Mount cable binder.



G01504-11



- Connect negative cable 27 of the battery.



- Remove filler plug 28 and add engine oil.

Engine oil	1.5 l (1.6 qt.)	Engine oil (SAE 10W/50) (☛ p. 310)
------------	-----------------	------------------------------------

- Mount and tighten filler plug 28.

### Finishing work

- Install the main silencer. (☛ p. 88)
- Install the fuel tank. (☛ p. 95)
- Mount the seat. (☛ p. 94)
- Remove the motorcycle from the lift stand. (☛ p. 11)
- Refill the coolant. (☛ p. 209)
- Take a short test ride.
- Execute the initialization run. (☛ p. 219)
- Take a short test ride.
- Read out the fault memory using the KTM diagnostics tool.
- Check the engine for leakage.
- Check the engine oil level. (☛ p. 210)
- Check the coolant level. (☛ p. 208)

## 18.3 Engine disassembly

### 18.3.1 Preparations



- Mount the special tool on the engine assembly stand.

Engine bracket (78029002000) (☛ p. 320)
Engine assembly stand (61229001000) (☛ p. 317)

- Mount the engine on the special tool.

**Info**  
Have an assistant help you or use a motorized hoist.

- Remove the kick starter.

### 18.3.2 Draining the engine oil

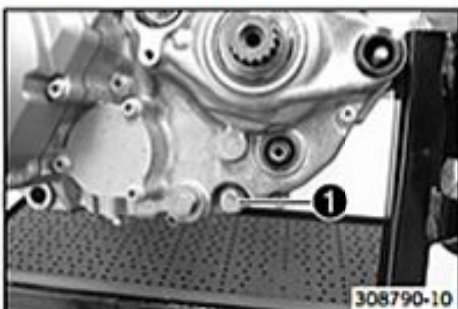

- Remove oil drain plug 1 with the magnet and seal ring.



- Remove engine oil screen plug ②.
- Completely drain the engine oil.



- Remove engine oil screen ③.



- Remove engine oil screen plug ④.

### 18.3.3 Removing the clutch push rod



- Remove clutch push rod ①.

### 18.3.4 Removing the oil filter

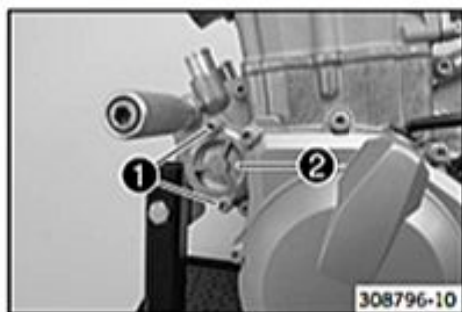

- Remove screws ①. Remove oil filter cover ② with the O-ring.

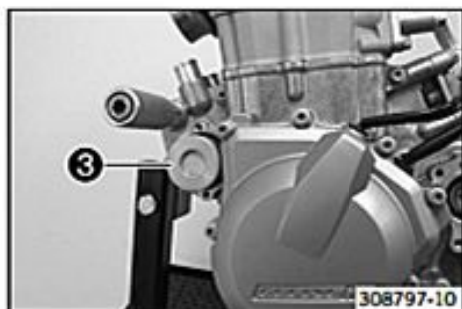

- Pull oil filter ③ out of the oil filter housing.

Circlip pliers reverse (51012011000) (☞ p. 314)

### 18.3.5 Removing the starter motor



- Remove screws ① and take off the starter motor.

### 18.3.6 Removing the kickstarter



- Remove screw ①. Take off the kickstarter.

### 18.3.7 Removing the spark plug



- Remove the spark plug using the special tool.

Spark plug wrench (75029172000) (☞ p. 319)

### 18.3.8 Removing the valve cover



- Remove screws ①. Remove the valve cover with the valve cover seal.

## 18.3.9 Removing the alternator cover

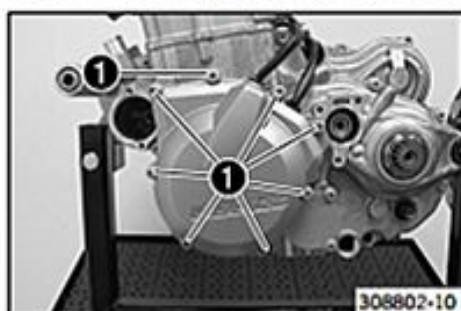

- Remove screws **1**. Remove the alternator cover.

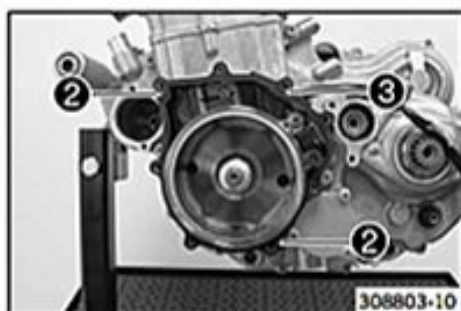

- Remove centering pins **2**. Take off the alternator cover gasket **3**.

## 18.3.10 Positioning the engine at ignition top dead center

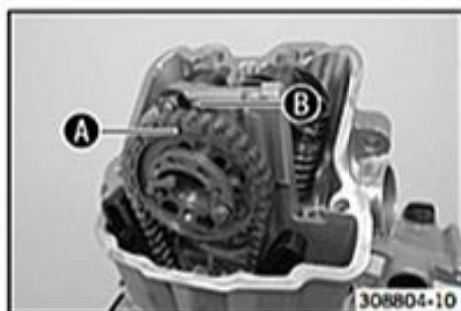

- Align camshaft marking **A** with marking **B** on the cylinder head.

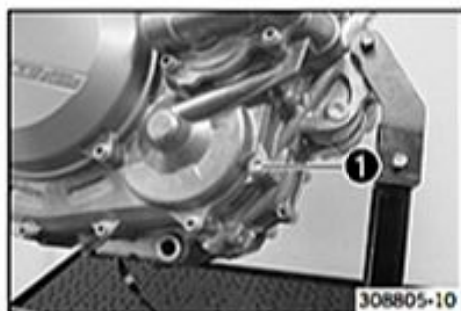

- Remove screw **1**.

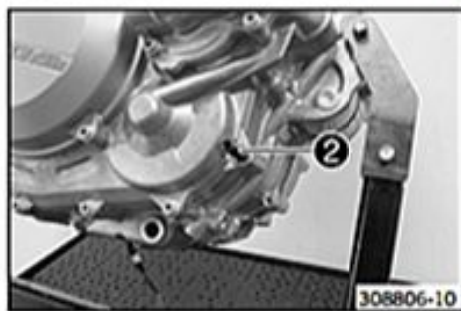

- Screw in special tool **2**.

Locking screw (113080802) (☞ p. 313)

## 18.3.11 Removing the timing chain tensioner



- Remove screw ①.

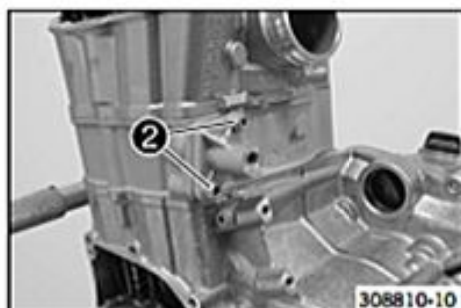

- Remove screw ②.
- Take off the chain adjuster with the gasket.

## 18.3.12 Removing the camshaft

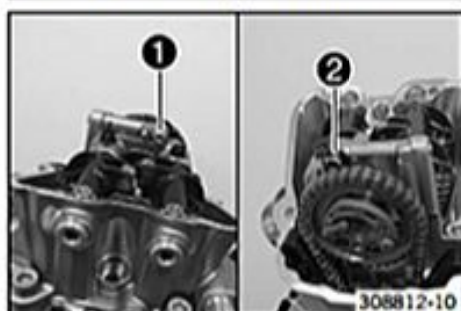

- Remove screw ①. Remove the camshaft support plate ②.



- Pull the camshaft out of the bearing seats. Take the timing chain off the camshaft gear. Remove the camshaft.

## 18.3.13 Removing the cylinder head

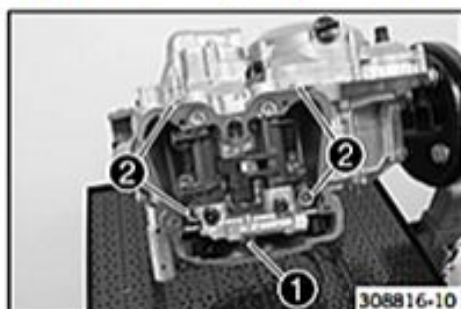

- Remove screw ①.
- Unscrew screws ② in a crisscross pattern and remove.
- Remove the cylinder head.
- Take off the dowels. Remove the cylinder head gasket.

## 18.3.14 Removing the piston



- Push the cylinder upward.

**Info**

Only push the cylinder as far up as necessary to take the piston pin out.

- Remove the piston pin retainer ①.
- Remove the piston pin.
- Take off the cylinder and piston.
- Push the piston upward out of the cylinder.

**Info**

If no further work is to be performed on the cylinder and piston, the piston can remain in the cylinder.

- Take off dowels ② and cylinder base gasket ③.

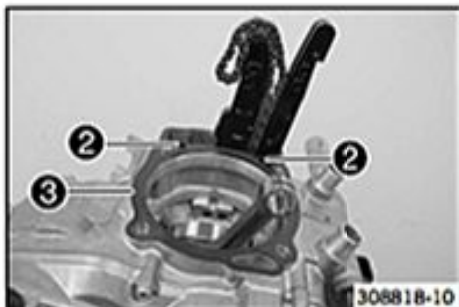

## 18.3.15 Removing the rotor



- Remove nut ① with the spring washer.



- Attach special tool ② to the rotor. Hold it tight using the special tool and pull off the rotor by turning the screw in.

Extractor (58012009000) (☛ p. 315)

- Remove the woodruff key.

## 18.3.16 Removing the timing chain guide rail

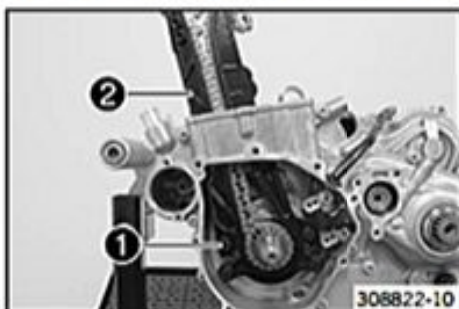

- Remove screw ①. Take off timing chain guide rail ② toward the top.



## 18.3.17 Removing the timing chain tensioning rail

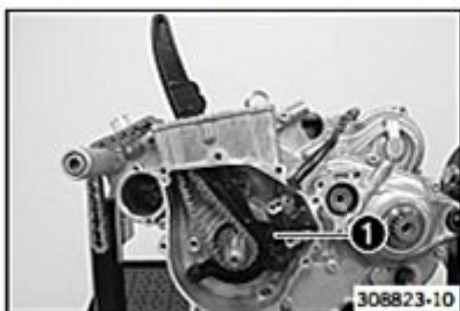

- Remove screw ①. Remove the timing chain tensioning rail from above.

## 18.3.18 Removing the timing chain securing guide



- Remove screws ①. Take off the timing chain securing guide.

## 18.3.19 Removing the timing chain

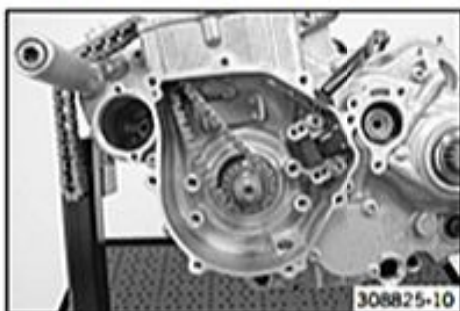

- Take off the timing chain.

**Info**

Identify the direction of travel.

## 18.3.20 Removing the ignition pulse generator



- Remove screws ①.
- Pull the cable support sleeve from the engine case. Take off the crankshaft position sensor.

## 18.3.21 Removing the suction pump

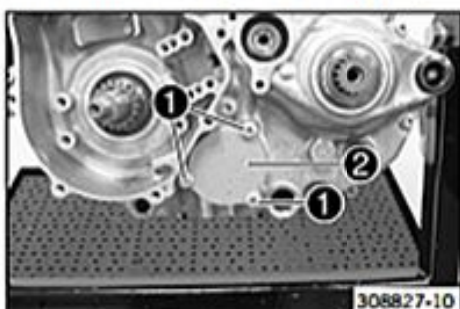

- Remove screws ①.
- Take off oil pump cover ② of the suction pump.

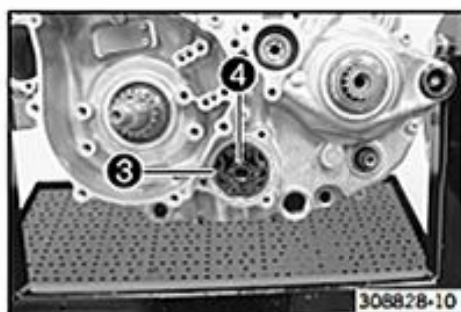

- Remove external rotor ③ and internal rotor ④.

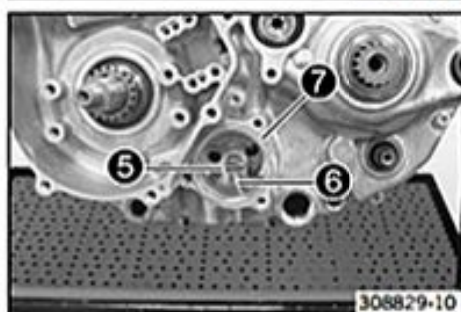

- Take off pin ⑤.
- Remove pin ⑥ upward.
- Remove O-ring ⑦.

### 18.3.22 Removing the water pump cover

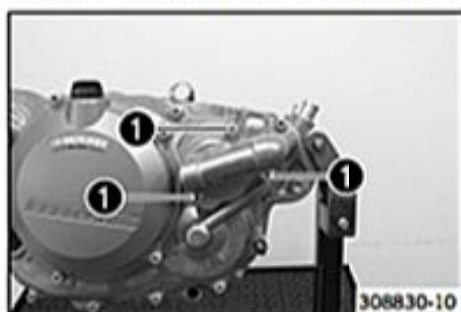

- Remove screws ①. Take off the water pump cover.
- Take off the water pump cover seal.

### 18.3.23 Removing the clutch cover

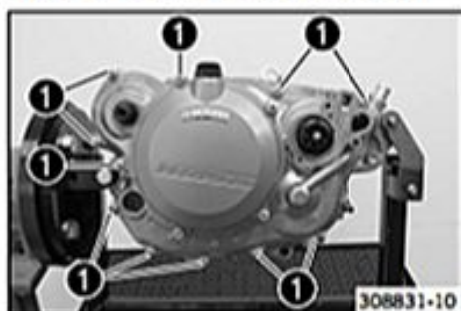

- Remove screws ①. Take off the clutch cover.



#### Info

If work is to be performed on the water pump, unscrew the nut of the water pump impeller.

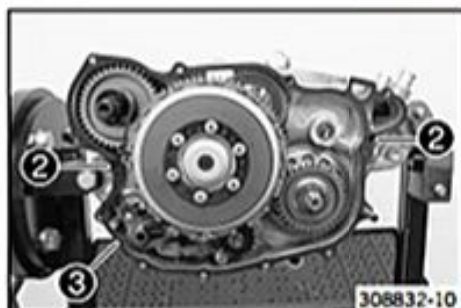

- Take out dowels ②. Take off clutch cover gasket ③.

## 18.3.24 Removing the clutch discs

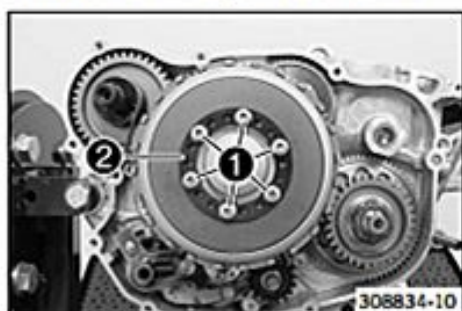

- Remove screws ①.
- Take off spring retainer ②.



- Take off spring washer ③.

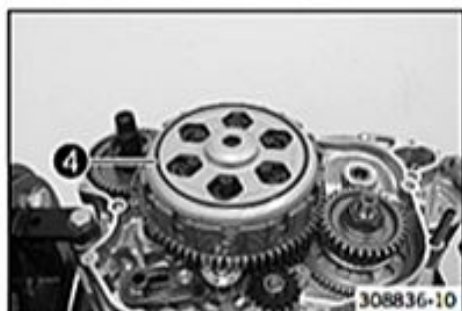

- Take off pretension ring ④.

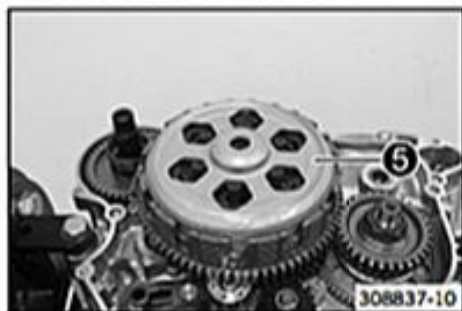

- Take off pressure cap ⑤.

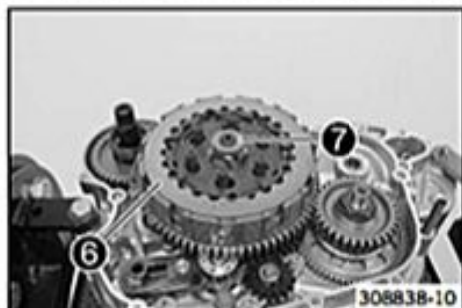

- Completely remove clutch disc pack ⑥.
- Remove clutch pressure piece ⑦.

## 18.3.25 Removing the primary gear nut

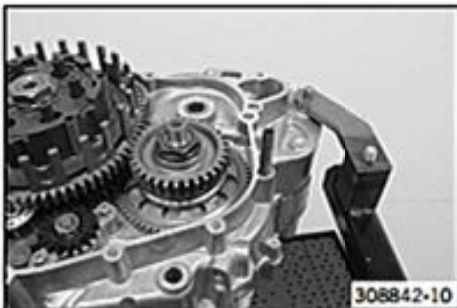

- Remove the special tool.

Locking screw (113080802) (☞ p. 313)

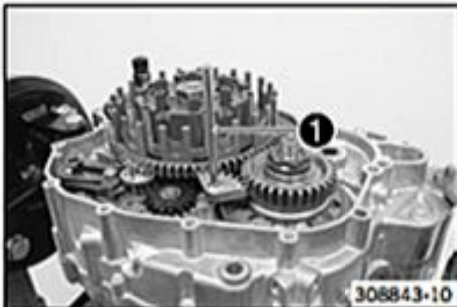

- Lock the outer clutch hub and primary gear using special tool ①.

Gear quadrant (80029004000) (☞ p. 321)

**i** Info  
LH thread

- Remove nut.

## 18.3.26 Removing the outer clutch hub

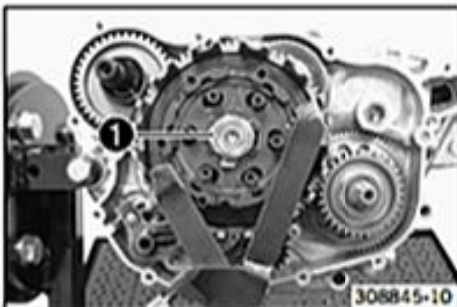

- Bend up the lock washer.
- Hold the inner clutch hub with the special tool. Loosen nut ①.

Clutch holder (51129003000) (☞ p. 315)

- Remove the nut with the lock washer. Dispose of the lock washer.

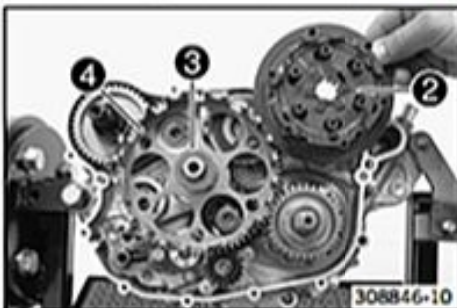

- Take off inner clutch hub ② and washer ③.

**i** Info  
The washer usually sticks to the inner clutch hub.

- Take off ④.



- Take off both needle bearings ⑤ and collar bushing ⑥.

## 18.3.27 Removing the torque limiter



- Remove the screw with the washer. Remove torque limiter **1**.
- Remove the washer.

## 18.3.28 Removing the starter idler gear



- Remove the lock ring. Take off the washer. Take off starter idler gear **1**.

## 18.3.29 Removing the kickstarter idler gear



- Apply counterpressure to kickstarter spring **1**. Remove screw **2**.
- Remove spring hanger **3**. Release tension on the kickstarter spring.
- Turn kickstarter shaft **4** counterclockwise and pull it out.

**i** Info

The stop disk of the kickstarter shaft usually sticks to the bearing.

## 18.3.30 Removing the kickstarter idler gear



- Remove the lock ring. Take off the washer. Take off kickstarter idler gear **1**.

## 18.3.31 Removing the shift shaft

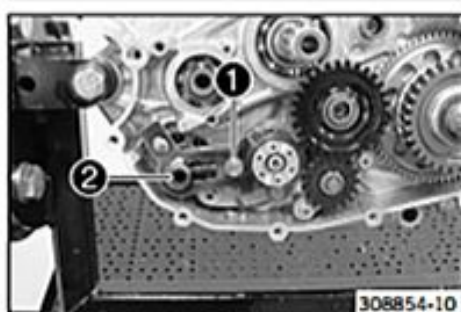

- Push sliding plate **1** away from the shift drum locating unit. Remove shift shaft **2** with the washer.

## 18.3.32 Removing the shift drum locating unit



- Remove screw 1.
- Push away locking lever 2 from shift drum locating unit 3 and remove the shift drum locating unit.
- Relieve tension from the locking lever.

## 18.3.33 Removing the locking lever

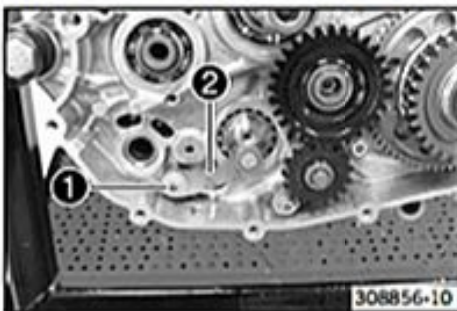

- Unscrew 1 and remove together with locking lever 2, washer, sleeve and spring.

## 18.3.34 Removing the oil pump gear wheels

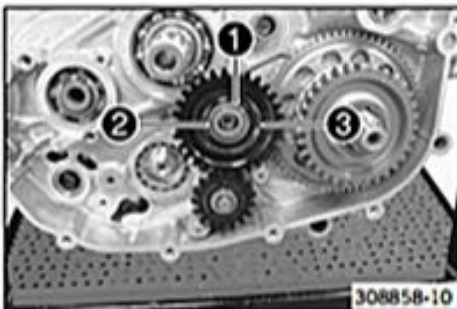

- Remove lock ring 1.
- Take off washer 2.
- Remove oil pump idler gear 3.



- Remove lock washer 4.
- Take off washer 5.
- Take off oil pump gear wheel 6.

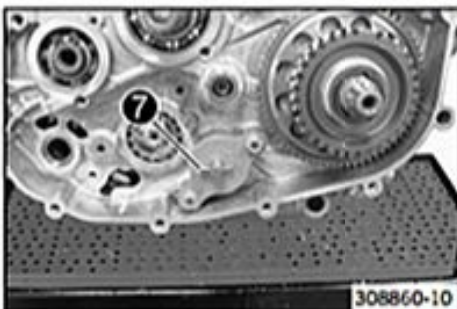

- Remove pin 7.

## 18.3.35 Removing the force pump

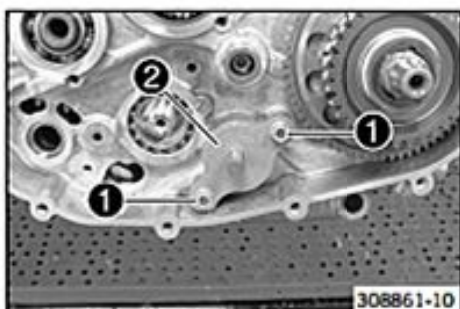

- Remove screws 1.
- Take off oil pump cover 2.

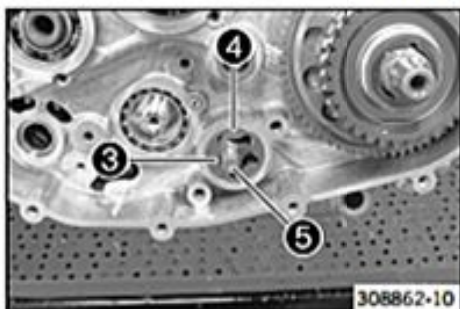

- Remove internal rotor 3 and external rotor 4.
- Remove the pin.
- Push oil pump shaft 5 inward and take it out of the engine from the ignition side.

## 18.3.36 Removing the primary gear

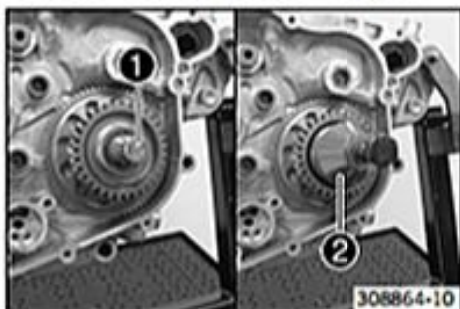

- Insert special tool 1 in the crankshaft.  
Protection cover (75029090000) (☞ p. 318)
- Install special tool 2.  
Extractor (75029021000) (☞ p. 317)
- Hold it using the special tool and pull off the primary gear by turning the screw in.
- Remove the special tools.

## 18.3.37 Removing the freewheel gear

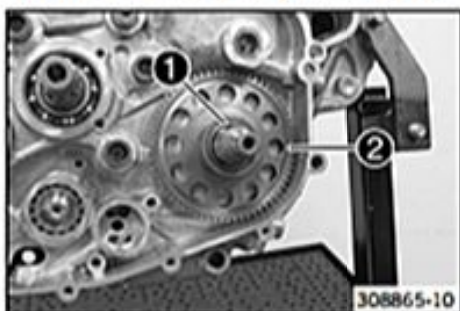

- Remove woodruff key 1.
- Take off freewheel gear 2.

## 18.3.38 Removing the left engine case section

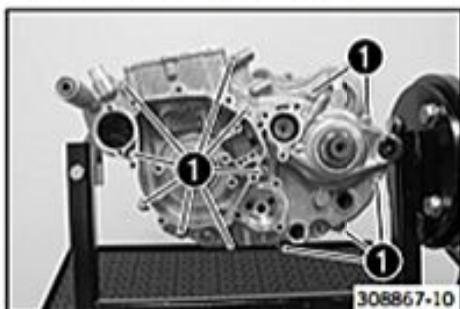

- Remove screws 1.

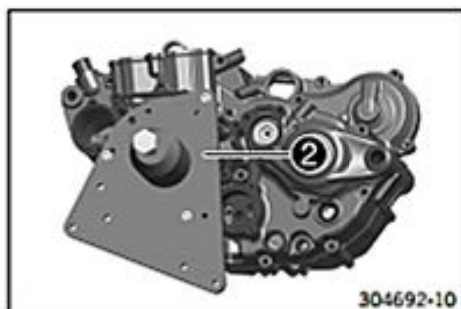

- Mount special tool ② with the appropriate screws.

Case separating tool (90129048000) (☞ p. 321)

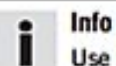
**Info**

Use the drill hole marked with 781.

- Tilt the left section of the engine case upward and remove the screw connections of the engine fixing arm.
- Take off the section of the engine case.

**Info**

Do not subject the section of the engine case to any stress.

- Remove the special tool.
- Take off the left section of the engine case.
- Remove spacer ③.

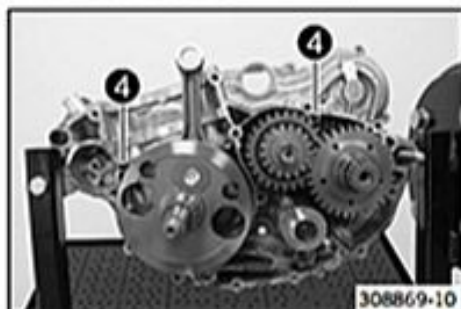

- Remove dowels ④.

### 18.3.39 Removing the shift rails

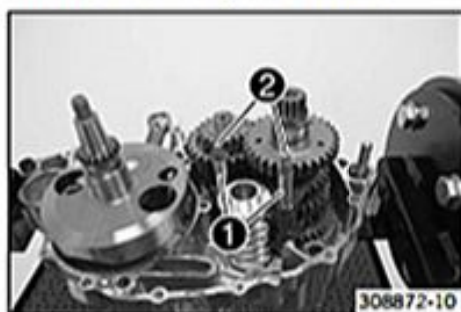

- Remove shift rails ① together with upper springs ② and the lower springs.

### 18.3.40 Removing the shift drum

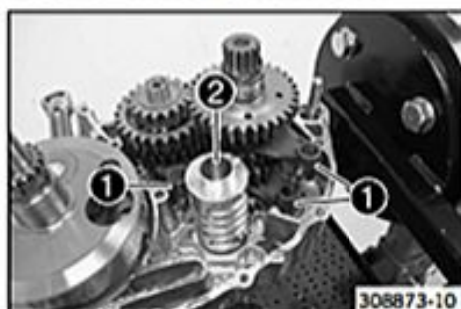

- Tilt shift forks ① to the side.

**Info**

Do not misplace the shift rollers.

- Remove shift drum ②.



## 18.3.41 Removing the shift forks



- Take shift forks **1** out of the shift grooves.

**Info**

Do not misplace shift rollers **2**.

## 18.3.42 Removing the transmission shafts



- Remove O-ring **1**.

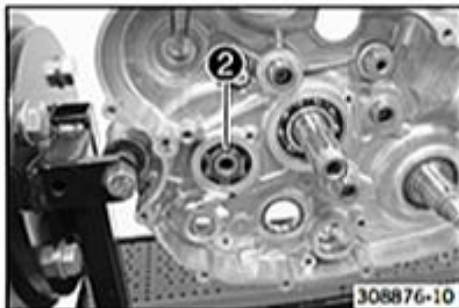

- Secure the engine in an upright position.
- Remove lock ring **2**.

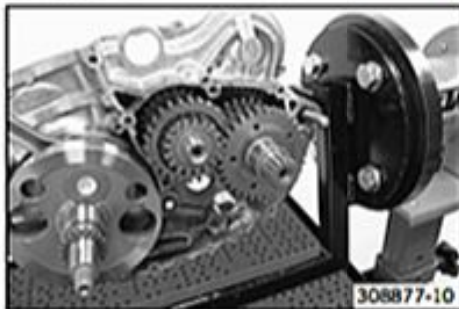

- Pull out both transmission shafts together from the bearing seats.

**Info**

Do not lose the washers.

## 18.3.43 Removing the crankshaft



- Attach the special tool to the crankshaft.

Protection cover (75029090000) (☛ p. 318)

- Mount special tool **1** onto the engine case with suitable screws.

Removal tool (78029049100) (☛ p. 320)

- Press the crankshaft out of the bearing seat.
- Take out crankshaft.
- Remove the special tools.
- Take off the right section of the engine case.

## 18.4 Work on individual parts

### 18.4.1 Work on the right section of the engine case

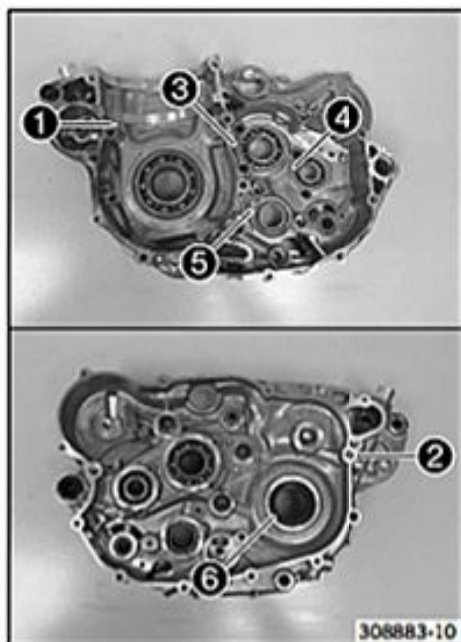

#### Preparatory work

- Remove the oil pressure regulator valve. (☛ p. 162)

#### Main work

- Remove all remaining dowels.
- Remove oil jets ① and ②.
- Remove the bearing retainer of main shaft bearing ③, of countershaft bearing ④ and of shift drum bearing ⑤.
- Remove any sealing mass remnants and clean the engine case section thoroughly.
- Warm the engine case section in an oven.

#### Guideline

150 °C (302 °F)
-----------------

- Knock the engine case section against a level wooden plate. This will cause the bearings to drop out of the bearing seats.



#### Info

Any bearings that remain in the engine case section must be removed using a suitable tool.

- Press out shaft seal ring ⑥ of the crankshaft from the inside to the outside.



#### Info

Do not press the shaft seal ring from the outside toward the inside, as there is a small collar on the inside.

- Press in the shaft seal ring from the outside toward the inside, with the open side facing outward.
- Warm the engine case section again.

#### Guideline

150 °C (302 °F)
-----------------

- Insert the new cold bearings into the bearing seats of the hot engine case section and, if necessary, use a suitable press drift to push the bearing from the inside to the outside, all the way to the stop or so it is flush.



#### Info

When pressing the bearing in, ensure that the engine case section is level to prevent damage.  
Only press the bearings in via the outer bearing race; otherwise, the bearings will be damaged when they are pressed in.

- After the engine case section has cooled, check that the bearings are firmly seated.



#### Info

If the bearings are not firmly seated after cooling, it is likely that they will rotate in the engine case when warm. In this case, the engine case must be renewed.

- Position all bearing locks. Mount and tighten the screws.

#### Guideline

Screw, bearing retainer	M5	6 Nm (4.4 lbf ft)	Loctite® 2701™
-------------------------	----	----------------------	----------------

- Mount and tighten oil jet ①.

#### Guideline

Oil jet, piston cooling	M5	2 Nm (1.5 lbf ft)	Loctite® 243™
-------------------------	----	----------------------	---------------

- Mount and tighten oil jet ②.

#### Guideline

Oil nozzle for conrod bearing lubrication	M6x0.75	4 Nm (3 lbf ft)	
---	---------	-----------------	--

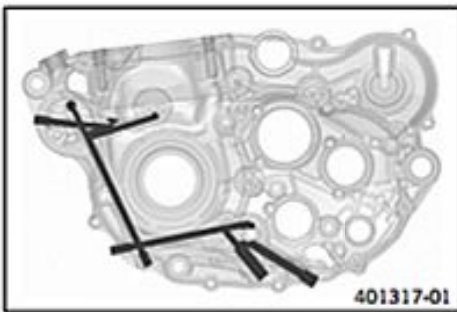

- Blow compressed air through all oil channels and check that they are clear.

#### Finishing work

- Install the oil pressure regulator valve. (☛ p. 163)

### 18.4.2 Work on the left section of the engine case

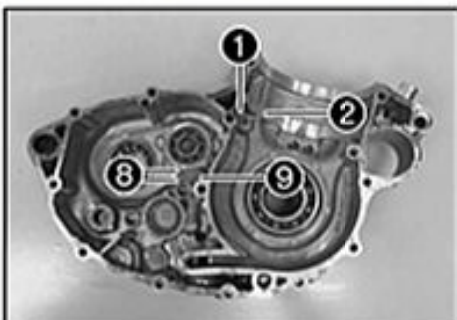

- Remove all remaining dowels.
- Remove screw 1.
- Remove oil spray tube 2.
- Remove screws 3.
- Remove membrane support plate 4 and the membrane.
- Remove the shaft seal ring of countershaft 5 and shift shaft 6.

#### Info

The shaft seal ring of crankshaft 7 can only be removed after the crankshaft bearing has been taken out because of a small external collar.

- Remove screws 8.
- Remove membrane support plate 9 and the membrane.
- Remove any sealing mass remnants and clean the engine case section thoroughly.
- Warm the engine case section in an oven.

#### Guideline

150 °C (302 °F)

- Knock the engine case section against a level wooden plate. This will cause the bearings to drop out of the bearing seats.

#### Info

Any bearings that remain in the engine case section must be removed using a suitable tool.

- Press out the shaft seal ring of crankshaft 7 from the inside to the outside.
- Press in the shaft seal ring from the outside toward the inside, with the open side facing outward.

#### Info

The shaft seal ring must be flush on the outside.

- Warm the engine case section again.

#### Guideline

150 °C (302 °F)

- Insert the new cold bearings into the bearing seats of the hot engine case section and, if necessary, use a suitable press drift to push the bearing all the way to the stop or so that it is flush.

#### Info

When pressing the bearing in, ensure that the engine case section is level to prevent damage.

Only press the bearings in via the outer bearing race; otherwise, the bearings will be damaged when they are pressed in.

- After the engine case section has cooled, check that the bearings are firmly seated.



**Info**

If the bearings are not firmly seated after cooling, it is likely that they will rotate in the engine case when warm. In this case, the engine case must be renewed.

- Press in the shaft seal ring of countershaft ⑤ and shift shaft ⑥ with the open side facing inward until it is flush.
- Position membrane support plate ⑨ together with the membrane.
- Mount and tighten screws ⑧.

Guideline

Screw, membrane	M3	1.5 Nm (1.11 lbf ft)	Loctite® 243™
-----------------	----	-------------------------	---------------

- Position membrane support plate ④ together with the membrane.
- Mount and tighten screws ③.

Guideline

Screw, membrane	M3	1.5 Nm (1.11 lbf ft)	Loctite® 243™
-----------------	----	-------------------------	---------------

- Position oil spray tube ②.
- Mount and tighten screw ①.

Guideline

Screw, oil spray tube	M4	5 Nm (3.7 lbf ft)	Loctite® 243™
-----------------------	----	----------------------	---------------

- Mount the dowels.
- Blow compressed air through all oil channels and check that they are clear.

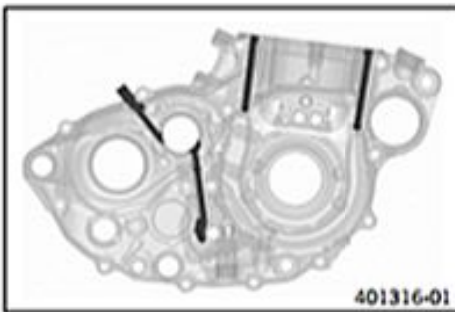

**18.4.3 Removing the oil pressure regulator valve**

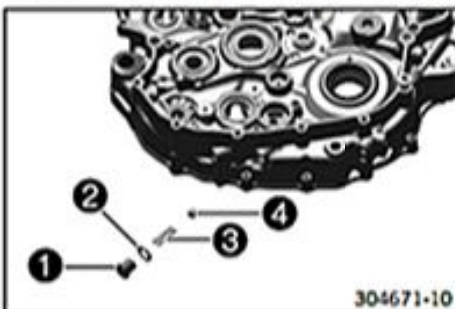

- Remove screw plug ① with sealing washer ②.
- Remove pressure spring ③ and ball ④.

**18.4.4 Checking spring length of oil pressure regulator valve**

**Preparatory work**

- Remove the oil pressure regulator valve. (☛ p. 162)

**Main work**

- Measure the spring length of the oil pressure regulator valve.

Oil pressure regulator valve	
Minimum length of preload spring	23.5 mm (0.925 in)

- If the measured value does not meet specifications:
  - Change the spring.



### Finishing work

- Install the oil pressure regulator valve. (☛ p. 163)

#### 18.4.5 Installing the oil pressure regulator valve

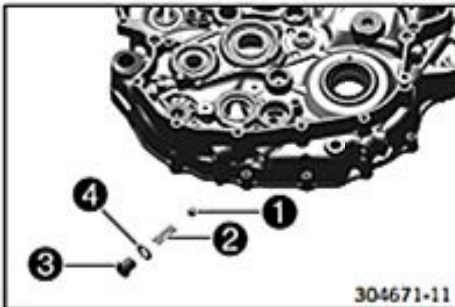

- Install ball ① and pressure spring ②.
- Mount and tighten plug ③ with sealing washer ④.

#### Guideline

Oil pressure control valve plug	M12x1.5	20 Nm (14.8 lbf ft)
---------------------------------	---------	------------------------

#### 18.4.6 Removing the crankshaft seal ring in the clutch cover

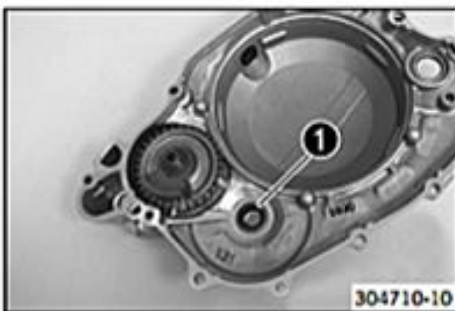

- Remove the crankshaft seal ring in clutch cover ①.

#### 18.4.7 Installing the crankshaft seal ring in the clutch cover



- Press crankshaft seal ring ① into the clutch cover with the open side flush toward the inside.
- Grease the sealing lip.

#### 18.4.8 Removing the water pump

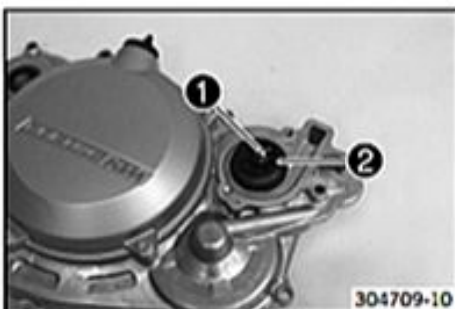

- Remove nut ①.
- Remove water pump impeller ②.

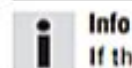

#### Info

If the water pump impeller cannot be detached, then the water pump shaft can be pressed out toward the inside.



- Remove balancer shaft ③.

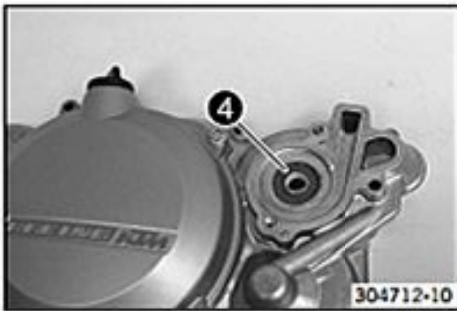

- Remove shaft seal ring **4**.

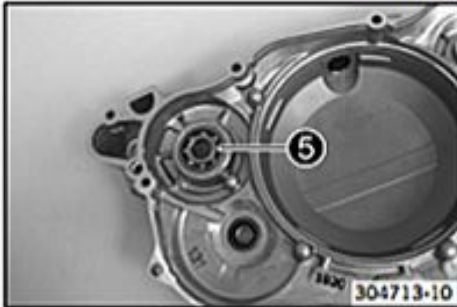

- Press out water pump bearing **5** toward the inside with an appropriate tool.



**Info**

Provide suitable support for the clutch cover while pressing out.

## 18.4.9 Installing the water pump

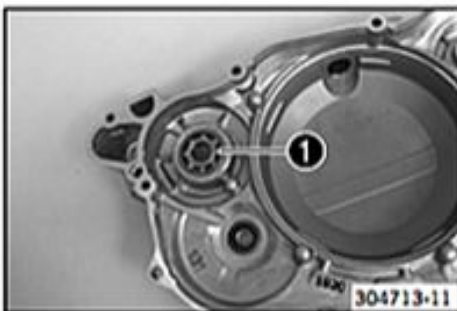

- Press water pump shaft bearing **1** in until it is flush using the appropriate tool.



**Info**

Support the clutch cover sufficiently when pressing in.

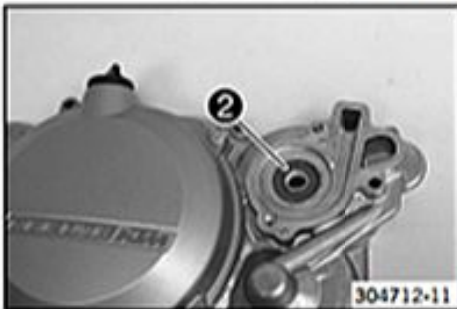

- Press shaft seal ring **2** all the way in.

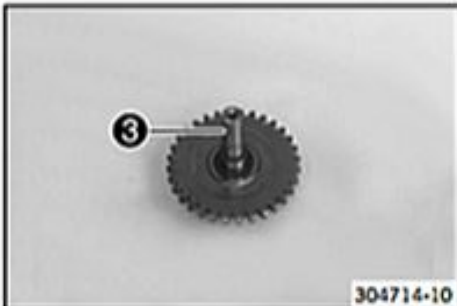

- Mount special tool **3** on the water pump shaft.

Mounting sleeve (90129005000) (☛ p. 321)

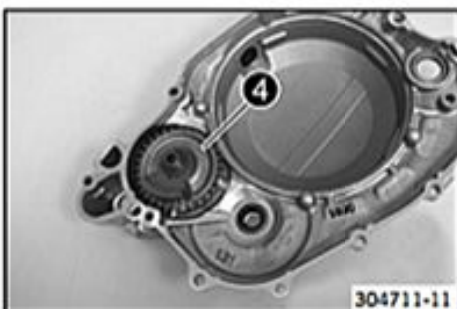

- Mount balancer shaft **4**.



**Info**

Be careful not to damage the shaft seal rings.

- Remove the special tool.

Mounting sleeve (90129005000) (☛ p. 321)

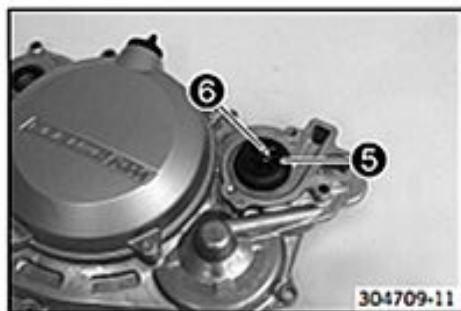

- Mount water pump impeller ⑤.
- Mount and tighten nut ⑥.

## Guideline

Nut, water pump impeller	M6	8 Nm (5.9 lbf ft)	Loctite® 243™
--------------------------	----	----------------------	---------------

## 18.4.10 Removing the timing chain sprocket



- Warm up the timing chain sprocket ① with a blow-dryer.
- Pull off the timing chain sprocket with the special tool.

Puller, 2-arm (60029033000) (☛ p. 316)



## Info

The timing chain sprocket is usually damaged by the disassembly and must be replaced.

## 18.4.11 Installing the timing chain sprocket

- i** **Info**  
Never clamp the crankshaft with a crankshaft journal in the bench vise and try to hammer on the timing chain sprocket. In such a case, the crank webs will be distorted rendering the crankshaft unserviceable.

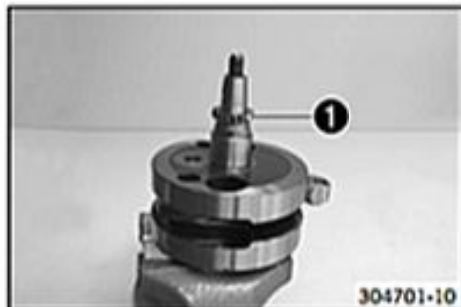

- Warm up the new timing chain sprocket and immediately push it onto the crankshaft.

## Guideline

180 °C (356 °F)

## 18.4.12 Changing the connecting rod, conrod bearing, and crank pin

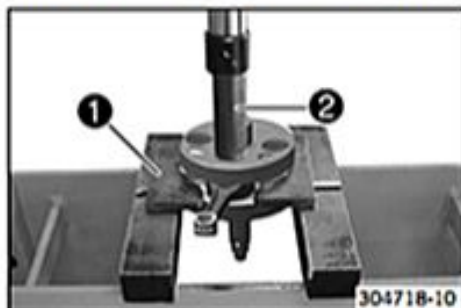

## Main work

- Position the crankshaft with special tool ① in the press.

Separator plate (78029009000) (☛ p. 320)

- Press the crank pin out of the upper crank web with special tool ②.

Pressing device for crankshaft, complete (75029047000) (☛ p. 318)



## Info

Hold the lower crank web.

- Take off the connecting rod and bearing.
- Press crank pin ③ out of the lower crank web.

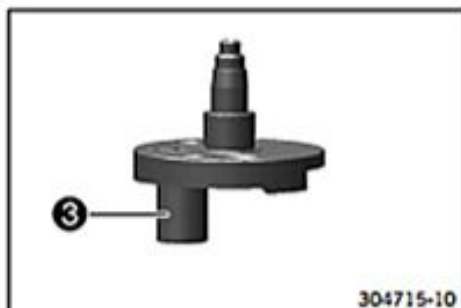

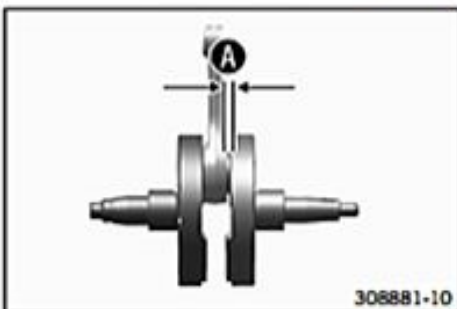
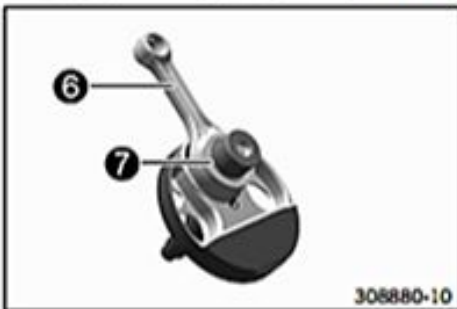
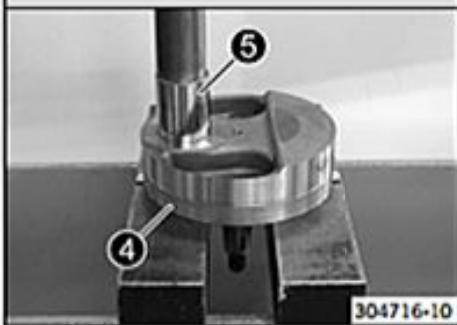
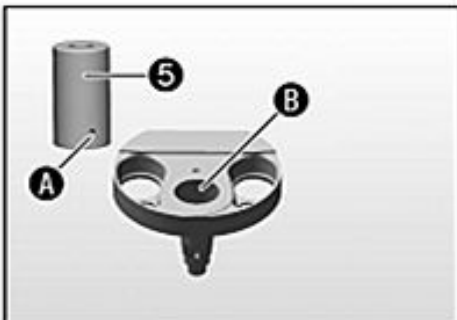

- Place the crank web onto special tool **4**.

Insert for crankshaft pressing device (78029008000) (☞ p. 320)



**Info**

The special tool must be positioned with the flat surface facing downward.

- Press the new crank pin **5** all the way in.
  - ✓ Oil channel **A** is aligned with oil channel **B**.
  - ✗ If the oil channels are not correctly aligned, the conrod bearing will not be supplied with oil.
- Blow compressed air through the oil channels to check that they are clear.

- Mount the new connecting rod **6**.



**Info**

Lubricate bearing **7** thoroughly.

- Position special tools **8** and **9** on the press.

Pressing device for crankshaft, complete (75029047000) (☞ p. 318)

Insert for crankshaft pressing device (78029008000) (☞ p. 320)

- Place the crank web in with the connecting rod and the bearing. Position the second crank web.

- Position special tool **4** with the heel at the bottom.

Insert for crankshaft pressing device (78029008000) (☞ p. 320)

- Press the upper crank web in as far as possible.



**Info**

The press mandrel must be applied above the crank pin.

- Take the crankshaft out of the special tool, and check the connecting rod for freedom of movement.

- Measure axial play **A** between the connecting rod and the crank webs using the special tool.

Feeler gauge (59029041100) (☞ p. 316)

Connecting rod - end play of lower conrod bearing	0.20... 0.45 mm (0.0079... 0.0177 in)
---	---------------------------------------

- If the measured value is less than the specification:
  - Correct until it complies with the specified value.

**Finishing work**

- Check the crankshaft run-out at bearing pin. (☞ p. 167)



### 18.4.13 Checking crankshaft run-out at bearing pin

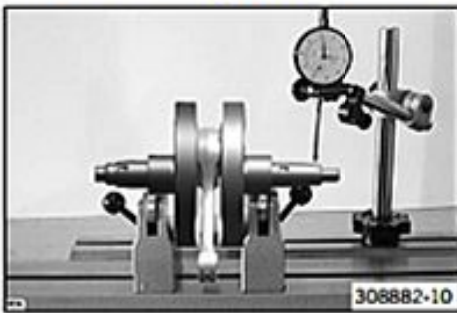

- Position the crankshaft on a roller block.
- Turn the crankshaft slowly.
- Check the crankshaft run-out on both bearing pins.

Crankshaft - run-out on bearing pin	≤ 0.16 mm (≤ 0.0063 in)
-------------------------------------	-------------------------

- If the crankshaft run-out at the bearing pin is larger than the specification:
  - Align the crankshaft.

### 18.4.14 Cylinder - Nikasil® coating



**Nikasil®** is a surface protection layer for a coating procedure developed by Mahle. The name is derived from the two materials used in this procedure - a layer of nickel into which is embedded the particularly hard silicone carbide. The most important advantages of the **Nikasil®** coating are very good heat conductivity, resulting in much improved performance, low wear, and a lightweight cylinder.

### 18.4.15 Checking/measuring the cylinder

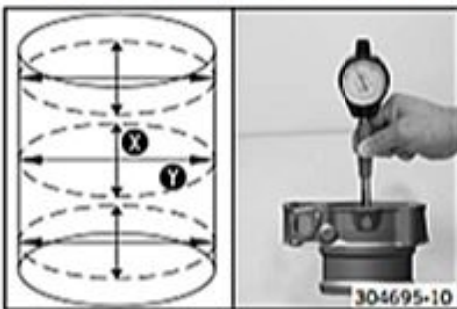

- Check the cylinder bearing surface for damage.
  - If the cylinder bearing surface is damaged:
    - Change the cylinder and piston.
- Measure the cylinder diameter at several locations on the **X**- and **Y**-axes using a micrometer to identify oval wear.

Guideline

Cylinder - drill hole diameter	
Size I	95.000... 95.012 mm (3.74015... 3.74062 in)
Size II	95.013... 95.025 mm (3.74066... 3.74113 in)



- The cylinder size **1** is labeled on the side of the cylinder.



- Using a straightedge and the special tool, check the sealing area of the cylinder head for distortion.

Feeler gauge (59029041100) (☞ p. 316)
---------------------------------------

Cylinder/cylinder head - sealing area distortion	≤ 0.10 mm (≤ 0.0039 in)
--	-------------------------

- If the measured value does not meet specifications:
  - Change the cylinder.

## 18.4.16 Checking/measuring the piston

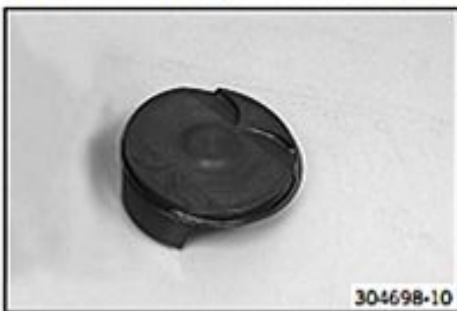

- Check the piston sliding surface for damage.
  - If the piston sliding surface is damaged:
    - Replace the piston and, if necessary, the cylinder.
- Check that the piston rings move easily in the piston ring grooves.
  - If the piston ring is stiff:
    - Clean the piston ring groove.



### Tip

An old piston ring can be used to clean the piston ring groove.

- Check the piston rings for damage.
  - If the piston ring is damaged:
    - Replace the piston ring.



### Info

Mount the piston ring with the marking facing upward.

- Check the piston pins for discoloration or signs of wear.
  - If the piston pin shows severe discoloration/signs of wear:
    - Replace the piston pin.
- Place the piston pin in the connecting rod and check the seating for play.
  - If the piston pin seating has excessive play:
    - Replace the connecting rod and piston pin.
- Measure the piston at the piston skirt, parallel to the gudgeon pin, at a distance of **A**.

### Guideline

Distance <b>A</b>	7 mm (0.28 in)
Piston - diameter	
Size I	94.93... 94.96 mm (3.7374... 3.7386 in)
Size II	94.94... 94.97 mm (3.7378... 3.739 in)



### Info

Piston dimensions **1** are marked on the piston head.

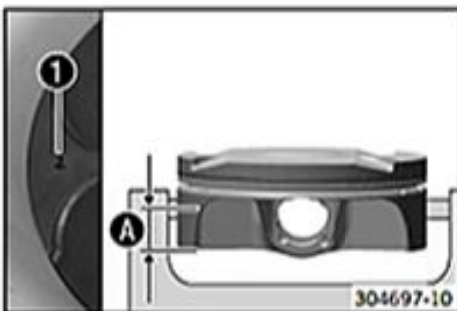

## 18.4.17 Checking the piston ring end gap



- Remove the piston ring from the piston.
- Place the piston ring in the cylinder and align it with the piston.

### Guideline

Under the upper edge of the cylinder	10 mm (0.39 in)
--------------------------------------	-----------------

- Measure the end gap with special tool **1**.

### Guideline

Piston ring end gap	
Compression ring	≤ 1.00 mm (≤ 0.0394 in)
Oil scraper ring	≤ 1.20 mm (≤ 0.0472 in)

Feeler gauge (59029041100) (☞ p. 316)

- If the end gap is more than the specified value:
  - Check/measure the cylinder. (☞ p. 167)
- If the cylinder wear is within the tolerance range:
  - Replace the piston ring.
- Mount the piston ring with the marking facing upward.

## 18.4.18 Measuring the piston/cylinder mounting clearance



- Check/measure the cylinder. (☞ p. 167)
- Check/measure the piston. (☞ p. 168)
- The smallest piston/cylinder mounting clearance equals the smallest cylinder bore diameter minus the largest piston diameter. The largest piston/cylinder mounting clearance equals the largest cylinder bore diameter minus the smallest piston diameter.

### Guideline

Piston/cylinder - mounting clearance	
Size I	0.040... 0.082 mm (0.00157... 0.00323 in)
Size II	0.043... 0.085 mm (0.00169... 0.00335 in)
Wear limit	0.120 mm (0.00472 in)

## 18.4.19 Checking the oil pumps



### Info

The following steps apply to both oil pumps.

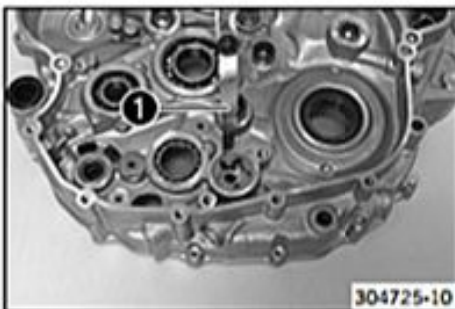

- Use special tool ❶ to measure the play between the external rotor and the engine case.

Feeler gauge (59029041100) (☞ p. 316)

### Oil pump

External rotor/engine case clearance	≤ 0.20 mm (≤ 0.0079 in)
--------------------------------------	-------------------------

- If the measured value does not meet specifications:
  - Change the oil pump and, if necessary, the engine case.
- Use special tool ❶ to measure the play between the external rotor and the internal rotor.

Feeler gauge (59029041100) (☞ p. 316)

### Oil pump

External rotor/internal rotor clearance	≤ 0.20 mm (≤ 0.0079 in)
---	-------------------------

- If the measured value does not meet specifications:
  - Replace the oil pump.

## 18.4.20 Disassembling the autodecompressor



- Take lock ring ❶ from the autodecompression shaft and dispose of it.

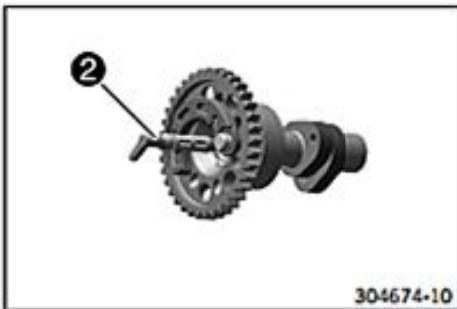

- Pull autodecompression shaft **2** out of the camshaft.

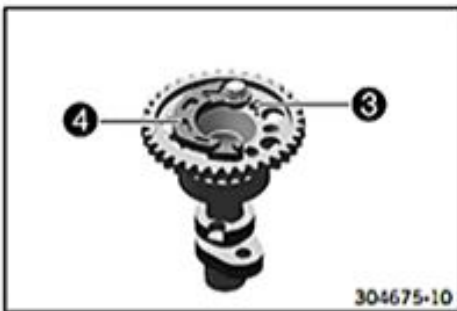

- Release and remove autodecompression spring **3**.



**Info**

Autodecompression weight **4** cannot be taken off.

### 18.4.21 Assembling the autodecompressor

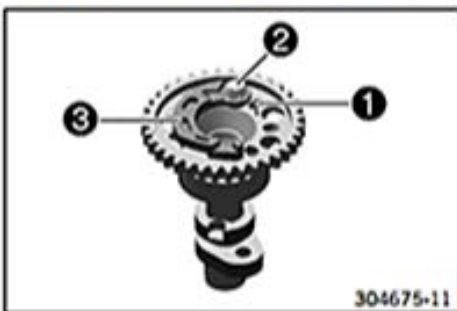

- Insert long flange **1** of the autodecompression spring in the hole, push the autodecompression spring over bearing bolt **2** and hook it into autodecompression weight **3**.

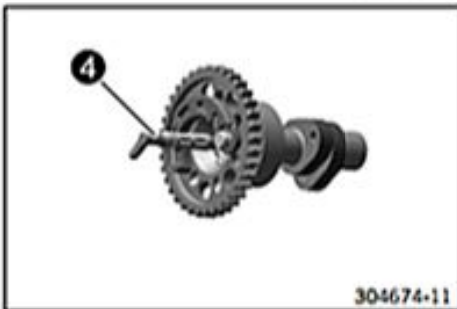

- Mount autodecompression shaft **4** in the camshaft.



- Mount new lock ring **5**.
- Perform a function check.
  - The autodecompression spring does not turn the autodecompression shaft back to the stop:
    - Pre-tension the autodecompression spring more or replace it.

## 18.4.22 Checking camshaft



- Check the camshaft for damage and wear.
  - If there is damage or wear:
    - Change the camshaft.
    - If the camshaft surface is damaged, check the oil supply of the camshaft and the rocker arm.
- Measure the cams of the camshaft.

Camshaft - cam height	
Exhaust	33.10... 33.30 mm (1.3031... 1.311 in)
Camshaft - cam height (all 450 models)	
Intake	33.90... 34.10 mm (1.3346... 1.3425 in)
Camshaft - cam height (alle 500 Modelle)	
Intake	34.40... 34.60 mm (1.3543... 1.3622 in)

- If the measured value does not meet specifications:
  - Change the camshaft.

## 18.4.23 Checking the timing assembly

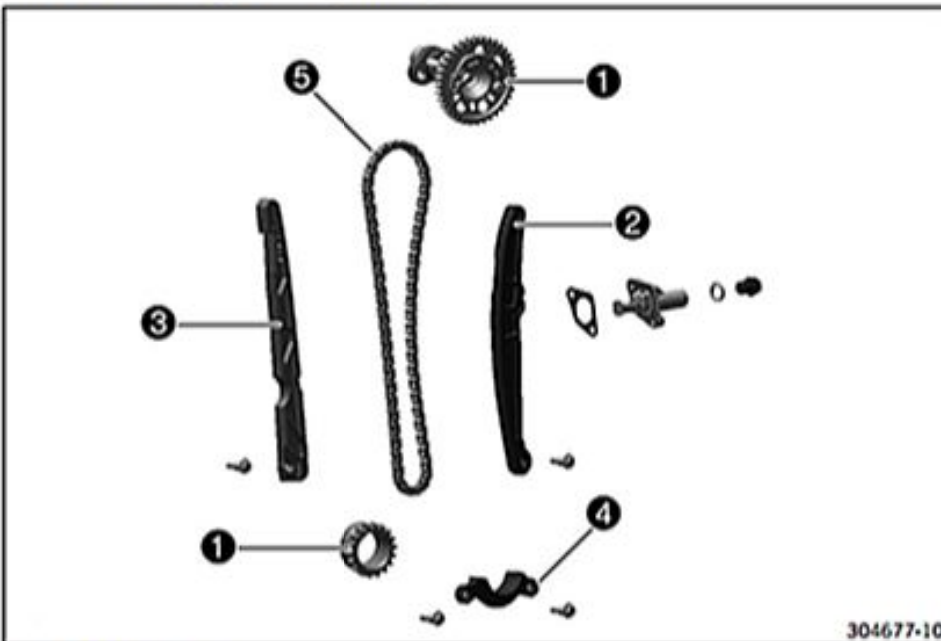

- Clean all parts well.
- Check the timing chain gear/timing chain sprocket **1** for damage and wear.
  - If there is damage or wear:
    - Change the camshaft/timing chain sprocket.
- Check the timing chain tensioning rail **2** for damage and wear.
  - If there is damage or wear:
    - Replace the timing chain tensioning rail.
- Check the timing chain guide rail **3** for damage and wear.
  - If there is damage or wear:
    - Replace the timing chain guide rail.
- Check the timing chain securing guide **4** for damage and wear.
  - If there is damage or wear:
    - Replace the timing chain securing guide.
- Check timing chain **5** for damage and wear.

- If there is damage or wear:
  - Replace the timing chain.
- Check the timing chain links for smooth operation. Let the timing chain hang down freely.
  - The chain links no longer align in a straight line:
    - Replace the timing chain.

## 18.4.24 Removing the rocker arm



- Remove screws 1 and 2 of the rocker arm shafts.
- Remove plugs 3 with the O-rings.

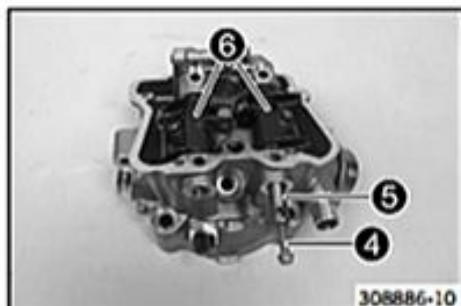

- Screw appropriate screw 4 into the rocker arm shafts. Pull out rocker arm shafts 5.
- Take off rocker arm 6.

## 18.4.25 Removing the valves



- Take the shims out of the valve spring retainers and lay them to one side according to their normal built-in position.
- Pretension the valve springs using the special tool.

Valve spring compressor (59029019000) (☛ p. 315)

Insert for valve spring lever (77029041000) (☛ p. 319)

- Remove valve keys 1 and relax the valve springs.



- Remove valve spring retainer 2 and the valve spring.
- Pull the valve out of the valve guide from below and remove valve stem seal 3 and valve spring seat 4.

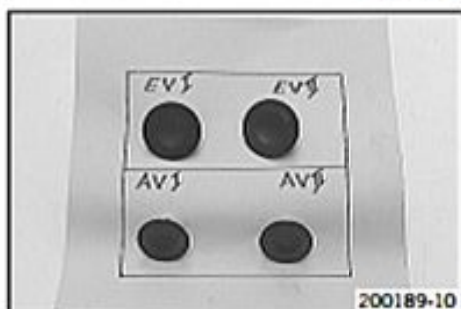

- Mark the valves according to their normal built-in position.



### Info

Place the valve into a box according to the installation position and label the box.

## 18.4.26 Changing camshaft bearing

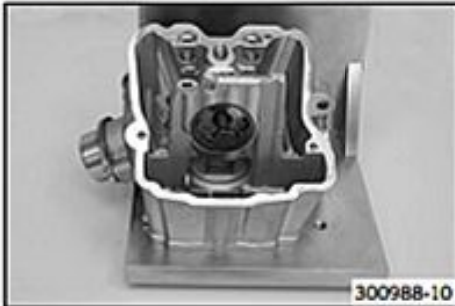

- Mount the cylinder head.

Clamping plate (75029050000) (☞ p. 318)

- Remove the large camshaft bearing using the special tool.

Push-out drift (75029051000) (☞ p. 318)

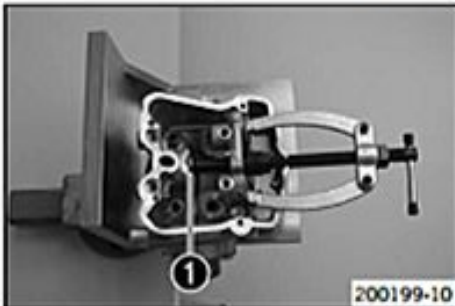

- Remove the small camshaft bearing ① using the special tool.

Bearing puller (15112017000) (☞ p. 313)

Insert for bearing puller (15112018100) (☞ p. 314)



- Press the small camshaft bearing in until flush using the special tool ②.

Push-in drift (75029044020) (☞ p. 318)



- Press the large camshaft bearing in until flush using special tool ③.

Push-in drift (75029044010) (☞ p. 317)

## 18.4.27 Checking the valves



### Info

The valve shaft is hard-chrome plated; wear generally appears at the valve guide.



- Check the run-out at the valve plate.

Valve

Run-out at valve plate

≤ 0.05 mm (≤ 0.002 in)

- If the measured value does not meet specifications:
  - Change the valve.

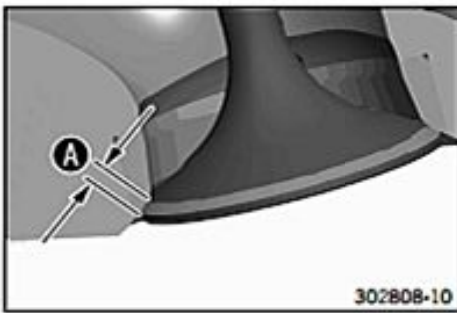

- Check sealing seat **A** on the valve.

Valve	
Intake sealing seat width	2.00 mm (0.0787 in)

Valve	
Exhaust sealing seat width	2.00 mm (0.0787 in)

- If the sealing area is not in the center of the valve seat or deviates from the specified value:
  - Rework the valve seat.

### 18.4.28 Checking valve springs



- Check the valve springs for breakage and wear (visual check).
  - If the valve spring is broken or worn:
    - Change the valve spring.
- Measure the length of the valve springs.

Valve spring	
Intake minimum length (without valve spring seat)	40.7 mm (1.602 in)

Valve spring	
Exhaust minimum length (without valve spring seat)	40.7 mm (1.602 in)

- If the measured value does not meet specifications:
  - Change the valve spring.

### 18.4.29 Checking valve spring seat



- Check the valve spring seat for breakage and wear (visual check).
  - If the valve spring seat is broken or worn:
    - Change the valve spring seat.
- Measure the thickness of the valve spring seat.

Valve spring	
Valve spring seat	1.8 mm (0.071 in)

- If the measured value does not meet specifications:
  - Change the valve spring seat.

### 18.4.30 Checking the cylinder head



- Check exhaust valve guides **1** using the special tool.

Limit plug gauge (77029026000) (☞ p. 319)
---

- If the special tool is easy to insert in the valve guide:
  - Change the valve guide and valve.

- Check intake valve guides **2** using the special tool.

Limit plug gauge (59029026006) (☞ p. 316)
---

- If the special tool is easy to insert in the valve guide:
  - Change the valve guide and valve.

- Check the sealing area of the spark plug thread and the valve seats from damage and cracking.

- If there is damage or cracking:
  - Change the cylinder head.



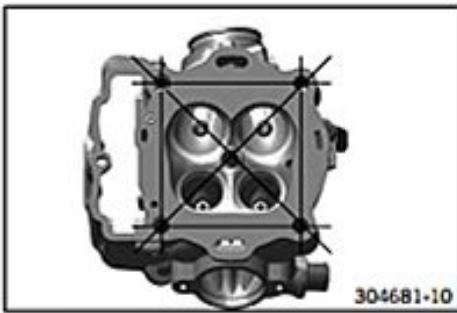

- Using a straightedge and the special tool, check the sealing area of the cylinder for distortion.

Feeler gauge (59029041100) (☞ p. 316)

Cylinder/cylinder head - sealing area distortion	≤ 0.10 mm (≤ 0.0039 in)
--	-------------------------

- If the measured value does not meet specifications:
  - Change the cylinder head.

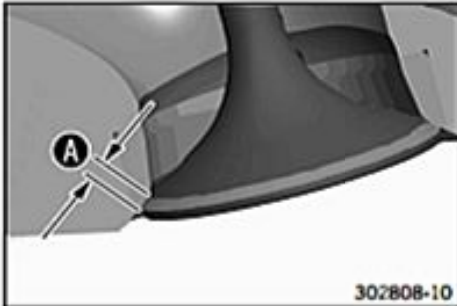

- Check sealing seat **A** of the valves.

Valve	
Intake sealing seat width	2.00 mm (0.0787 in)

Valve	
Exhaust sealing seat width	2.00 mm (0.0787 in)

- If the measured value does not meet specifications:
  - Rework the valve seat.

- Blow compressed air through all oil channels and check that they are clear.

### 18.4.31 Checking the rocker arm shafts



- Check the rocker arm shafts for damage and wear.

- If there is damage or wear:
  - Change the rocker arm shafts.

### 18.4.32 Installing the valves

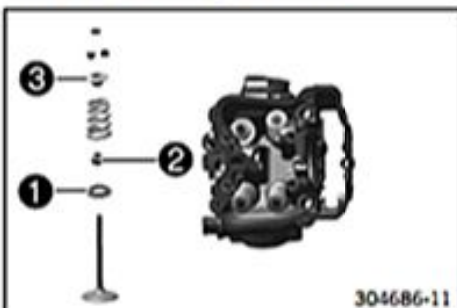

- Position valve spring seats **1**. Install new valve stem seals **2**.
- Mount the valves according to their normal built-in position.
- Mount the springs and spring retainers **3**.



- Pretension the valve springs using the special tool.

Valve spring compressor (59029019000) (☞ p. 315)

Insert for valve spring lever (77029041000) (☞ p. 319)



- Mount the valve keys.

**i Info**

When mounting the valve keys, check that they are seated correctly; preferably, fix the valve keys to the valve with a little grease.

- Place shims into the valve spring retainers according to the installation position.

### 18.4.33 Installing the rocker arm

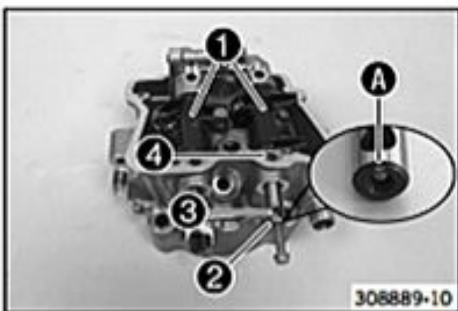

- Position rocker arm **1** and push in rocker arm shafts **2**.

✓ Markings **A** face upward.

**i Info**

Make sure that the tapped hole of the rocker arm shaft is positioned facing outwards.

Align drill holes **3** of the rocker arm shafts with drill holes **4** of the cylinder head.



- Install and tighten screws **5** and **6** of the rocker arm shafts.

Guideline

Screw, rocker arm bearing	M7x1	15 Nm (11.1 lbf ft)
---------------------------	------	------------------------

- Install and tighten plug **7** with O-rings.

Guideline

Plug, rocker arm	M14x1.25	20 Nm (14.8 lbf ft)
------------------	----------	------------------------

### 18.4.34 Checking the clutch

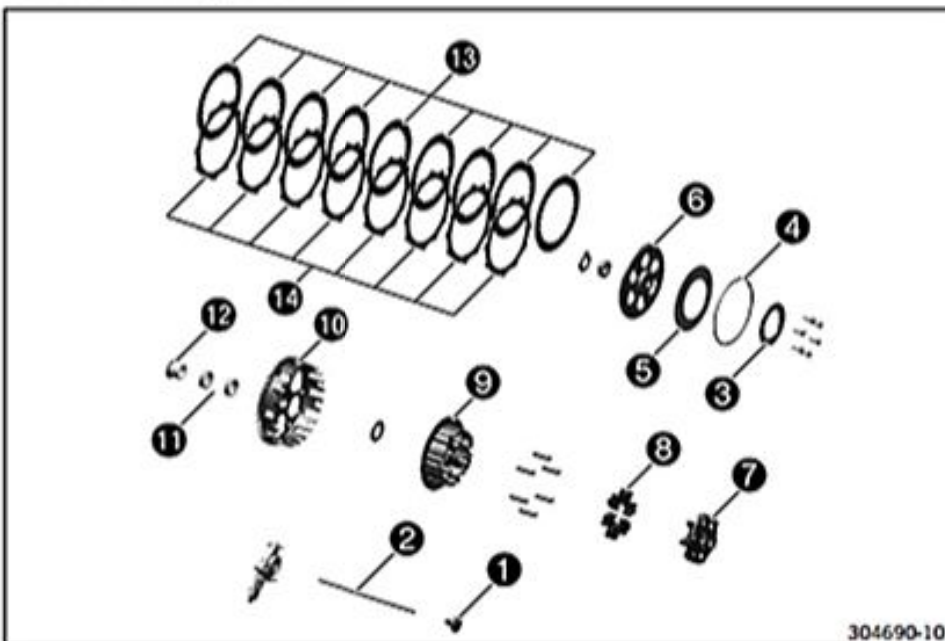

- Check pressure piece **1** for damage and wear.
  - If there is damage or wear:
    - Change the pressure piece.
- Place push rod **2** on a level surface and check for run-out.
  - If there is run-out:

- Change the push rod.
- Check spring retainer ③ for damage and wear.
  - If there is damage or wear:
    - Change the spring retainer.
- Check pretension ring ④ for damage and wear.
  - If there is damage or wear:
    - Change the pretension ring.
- Check spring washer ⑤ for damage and wear.
  - If there is damage or wear:
    - Change the spring washer.
- Check the thrust face of pressure cap ⑥ for damage and wear.
  - If there is damage or wear:
    - Change the pressure cap.
- Check clutch center ⑦ for damage and wear.
  - If there is damage or wear:
    - Change the clutch center.
- Check damping rubber ⑧ for damage and wear.
  - If there is damage or wear:
    - Change the damping rubbers.
- Check the inner clutch hub ⑨ for damage and wear.
  - If there is damage or wear:
    - Change the inner clutch hub.
- Check the contact surfaces of the clutch facing disks in outer clutch hub ⑩ for damage and wear.
  - If there is damage or wear:
    - Change the clutch facing discs and the outer clutch hub.
- Check needle bearings ⑪ and collar bushing ⑫ for damage and wear.
  - If there is damage or wear:
    - Change the needle bearings and collar bushing.
- Check the intermediate clutch discs ⑬ for damage and wear.
  - If the intermediate clutch discs are not level and have pittings:
    - Change all intermediate clutch discs.
- Check clutch facing discs ⑭ for discoloration and scoring.
  - If there is discoloration or scoring:
    - Change all clutch facing discs.
- Check the thickness of clutch facing discs ⑮.

Clutch facing disc - thickness	≥ 1.9 mm (≥ 0.075 in)
--------------------------------	-----------------------

- If the clutch facing disc does not meet specifications:
  - Change all clutch facing discs.

## 18.4.35 Checking the shift mechanism

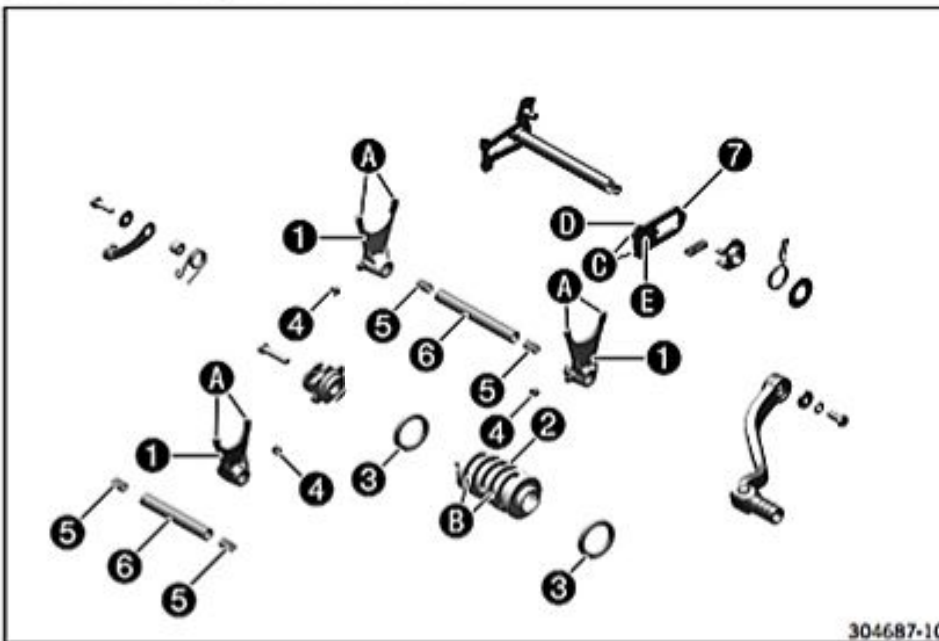

304687-10

- Check shift forks **1** at leaf **A** for wear.

## Shift fork

Thickness at leaf

4.85... 4.95 mm (0.1909... 0.1949 in)

- If the measured value does not meet specifications:
    - Change the shift fork.
- Check shift grooves **B** of shift drum **2** for wear.
  - If the shift groove is worn:
    - Change the shift drum.
- Check the seat of the shift drum in grooved ball bearing **3**.
  - If the shift drum is not correctly seated:
    - Change the shift drum and/or the grooved ball bearing.
- Check grooved ball bearing **3** for smooth operation and wear.
  - If the grooved ball bearing does not move easily or is worn:
    - Change the grooved ball bearing.
- Check shift rollers **4** for surface damage and cracking.
  - If the shift roller exhibits surface damage or cracking:
    - Change the shift drum.
- Check springs **5** of the shift rails for damage and wear.
  - If the spring is damaged or worn:
    - Change the spring of the shift rail.
- Check shift rails **6** on a flat surface for run-out.
  - If there is run-out:
    - Change the shift rail.
- Check the shift rails for scoring, seizure marks, and stiffness in the shift fork.
  - If the shift rail has scoring, seizure marks, or does not move easily in the shift fork:
    - Change the shift rail.
- Check sliding plate **7** for wear on contact areas **C**.
  - If the sliding plate is worn:
    - Change the sliding plate.
- Check return surface **D** on the sliding plate for wear.
  - If there is severe grooving:
    - Change the sliding plate.

- Check guide bolts **E** for firm seating and wear.
  - If the guide bolts are loose or worn:
    - Change the sliding plate.
- Preassemble the shift shaft. (☛ p. 179)

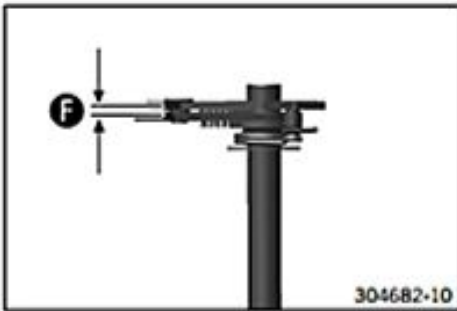

- Check clearance **F** between the sliding plate and the shift quadrant.

Shift shaft - play in sliding plate/shift quadrant	0.40... 0.80 mm (0.0157... 0.0315 in)
--	---------------------------------------

- If the measured value does not meet specifications:
  - Change the sliding plate.

### 18.4.36 Preassembling the shift shaft

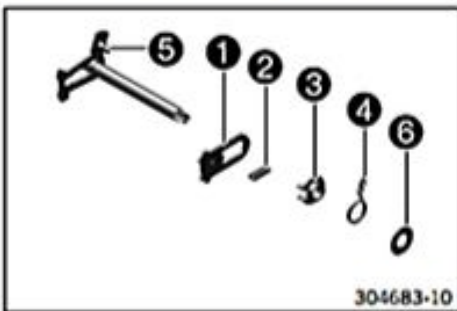

- Secure the short end of the shift shaft in the bench vise.

Guideline

Use soft jaws.

- Mount sliding plate **1** with the guide pin facing downward and put the guide pin on the shift quadrant.
- Mount pressure spring **2**.
- Slide on spring guide **3**, push return spring **4**, with the offset end facing upward, over the spring guide and lift the offset end over abutment bolt **5**.
- Mount stop disk **6**.

### 18.4.37 Disassembling the main shaft

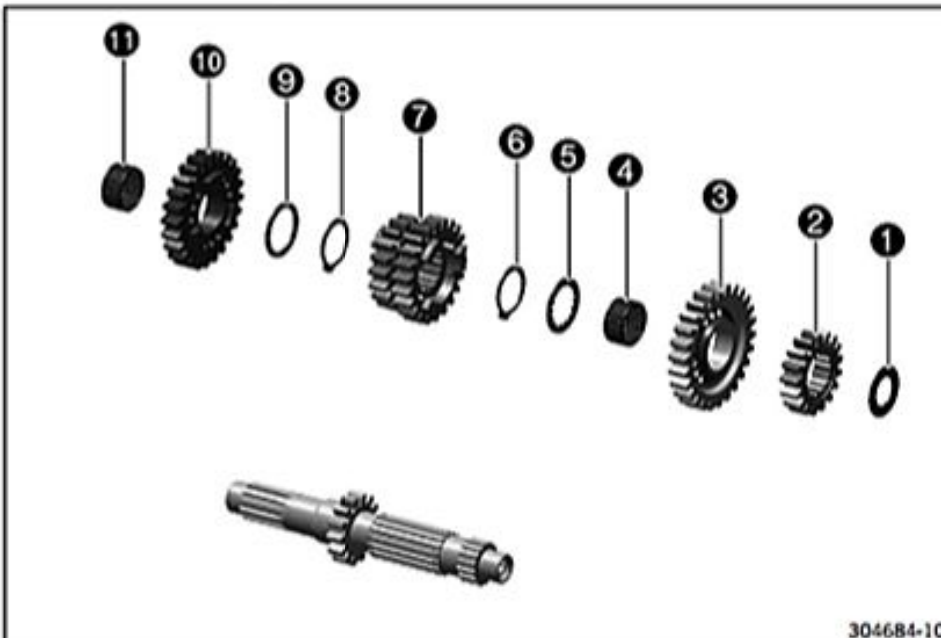

- Secure the main shaft with the toothed end facing downward in the vise.

Guideline

Use soft jaws.

- Remove stop disk **1** and 2nd-gear fixed gear **2**.
- Remove 6th-gear idler gear **3**.
- Remove the split needle bearing **4** and stop disk **5**.
- Remove lock ring **6**.
- Remove 3rd/4th-gear sliding gear **7**.

- Remove lock ring ⑧.
- Remove stop disk ⑨ and 5th-gear idler gear ⑩.
- Remove split needle bearing ⑪.

## 18.4.38 Assembling the main shaft

**i** Info  
Use new lock rings with every repair.

### Preparatory work

- Carefully grease all parts before assembling.
- Check the transmission. (☛ p. 182)

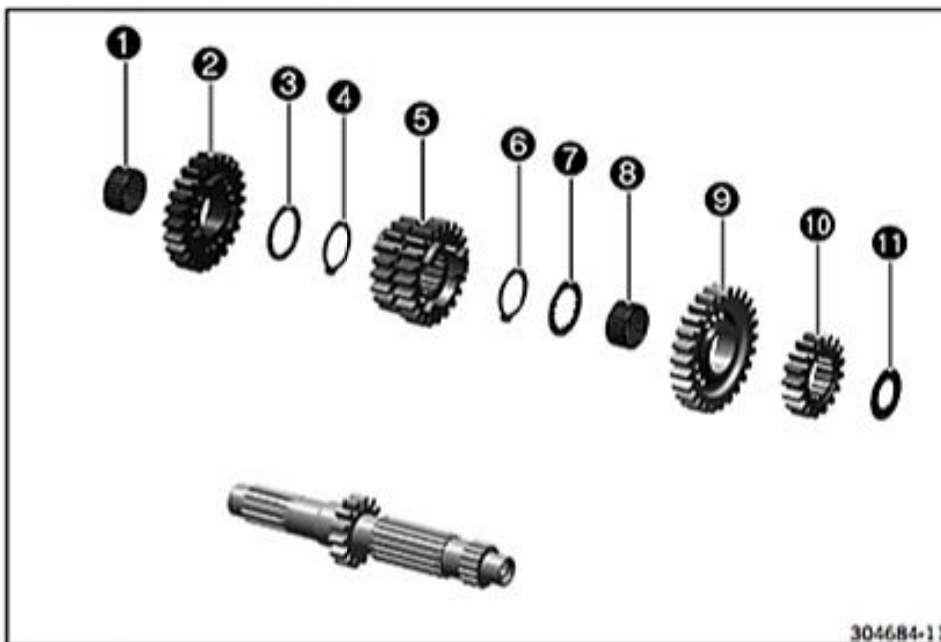

304684-11

### Main work

- Secure the main shaft with the toothed end facing downward in the vise.

#### Guideline

Use soft jaws

- Mount split needle bearing ①, attach 5th-gear idler gear ② with the shift dogs facing upward.
- Mount stop disk ③ and lock ring ④.
- Push on the 3rd/4th-gear sliding gear ⑤ with the small gear wheel pointing downward, and mount lock ring ⑥.
- Push on stop disk ⑦ and split needle bearing ⑧.
- Attach 6th-gear idler gear ⑨ with the shift dogs facing downward.
- Attach 2nd-gear fixed gear ⑩ with the collar facing downward and stop disk ⑪.
- Finally, check all gear wheels for smooth operation.

## 18.4.39 Disassembling the countershaft

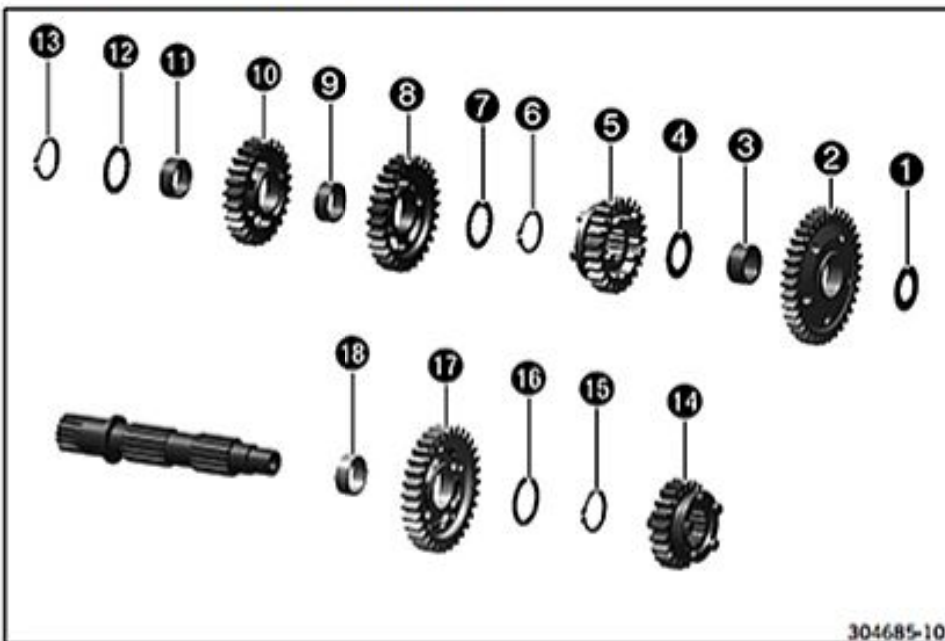

304685-10

- Fix the countershaft in the vice with the toothed end facing downward.

Guideline

Use soft jaws

- Remove stop disk ① and 1st-gear idler gear ②.
- Remove needle bearing ③ and stop disk ④.
- Remove 5th-gear sliding gear ⑤ and lock ring ⑥.
- Remove stop disk ⑦ and 3rd-gear idler gear ⑧.
- Remove needle bearing ⑨ and 4th-gear idler gear ⑩.
- Remove needle bearing ⑪ and stop disk ⑫.
- Remove lock ring ⑬ and 6th-gear sliding gear ⑭.
- Remove lock ring ⑮ and stop disk ⑯.
- Remove 2nd-gear idler gear ⑰ and needle bearing ⑱.

## 18.4.40 Assembling the countershaft



## Info

Use new lock rings with every repair.

## Preparatory work

- Carefully grease all parts before assembling.
- Check the transmission. (☛ p. 182)

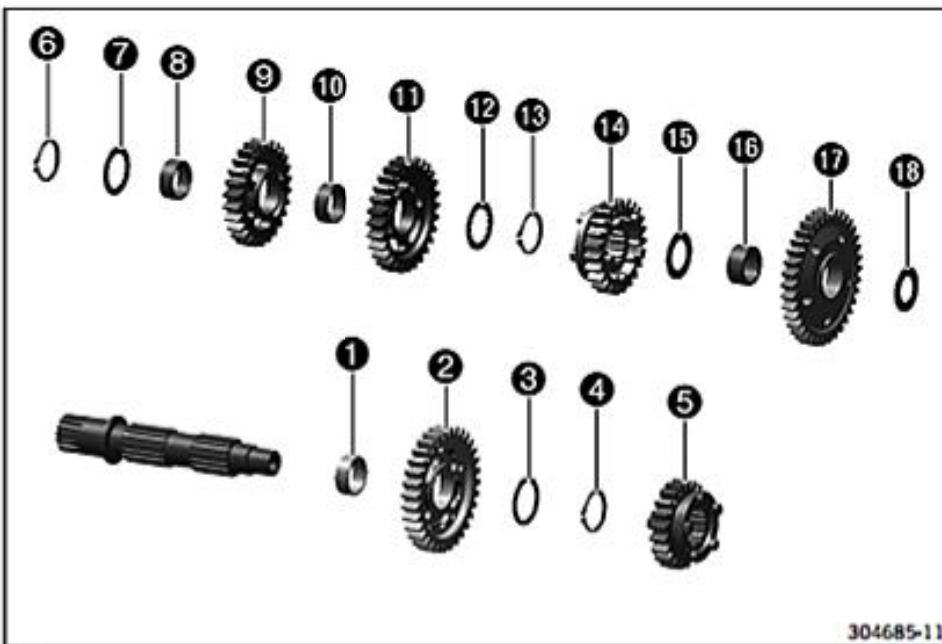

304685-11

### Main work

- Fix the countershaft in the vice with the toothed end facing downward.

#### Guideline

Use soft jaws

- Mount needle bearing ① and 2nd-gear idler gear ② onto the countershaft with the protruding collar facing downward.
- Mount stop disk ③ and lock ring ④.
- Mount the 6th-gear sliding gear ⑤ with the shift groove facing up.
- Mount lock ring ⑥ and stop disk ⑦.
- Mount needle bearing ⑧ and the 4th-gear idler gear ⑨ with the collar facing up.
- Mount needle bearing ⑩ and the 3rd-gear idler gear ⑪ with the collar facing down.
- Mount stop disk ⑫ and lock ring ⑬.
- Mount the 5th-gear sliding gear ⑭ with the shift groove facing down and stop disk ⑮.
- Mount needle bearing ⑯, 1st-gear idler gear ⑰ with the recess facing down and stop disk ⑱.
- Finally, check all gear wheels for smooth operation.

### 18.4.41 Checking the transmission

#### Condition

The transmission has been disassembled.



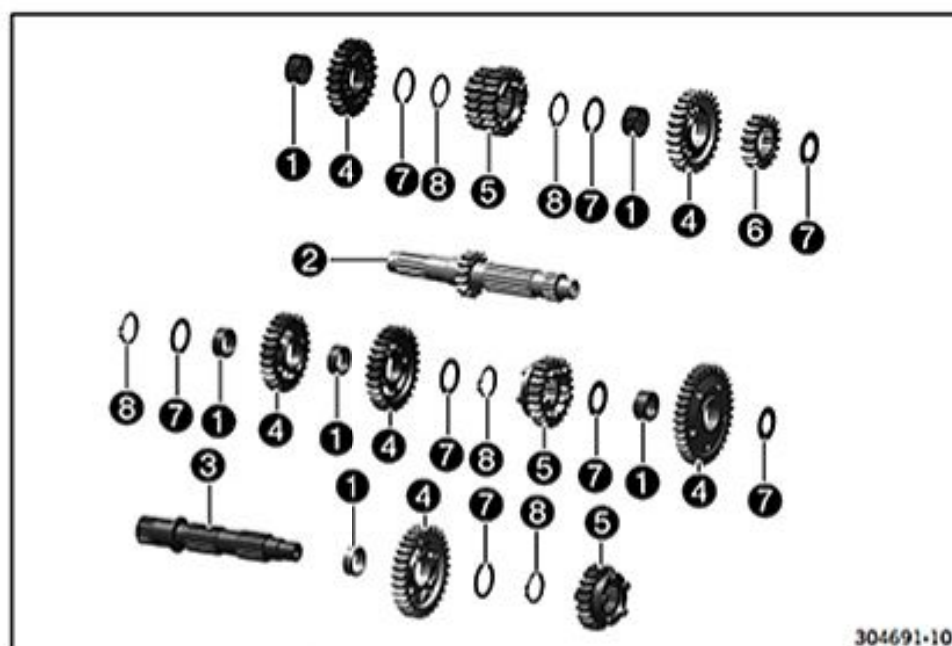

304691-10

- Check needle bearings **1** for damage and wear.
  - If there is damage or wear:
    - Change the needle bearings.
- Check the pivot points of main shaft **2** and countershaft **3** for damage and wear.
  - If there is damage or wear:
    - Change the main shaft and/or countershaft.
- Check the tooth profiles of main shaft **2** and countershaft **3** for damage and wear.
  - If there is damage or wear:
    - Change the main shaft and/or countershaft.
- Check the pivot points of idler gears **4** for damage and wear.
  - If there is damage or wear:
    - Change the gear wheel pair.
- Check the shift dogs of idler gears **4** and sliding gears **5** for damage and wear.
  - If there is damage or wear:
    - Change the gear wheel pair.
- Check the tooth faces of idler gears **4**, sliding gears **5**, and fixed gear **6** for damage and wear.
  - If there is damage or wear:
    - Change the gear wheel pair.
- Check the tooth profiles of sliding gears **5** for damage and wear.
  - If there is damage or wear:
    - Change the gear wheel pair.
- Check sliding gear **5** for smooth operation in the profile of main shaft **2**.
  - If the sliding gear does not move freely:
    - Change the sliding gear or the main shaft.
- Check sliding gears **5** for smooth operation in the profile of countershaft **3**.
  - If the sliding gear does not move freely:
    - Change the sliding gear or the countershaft.
- Check stop disks **7** for damage and wear.
  - If there is damage or wear:
    - Change the stop disks.
- Use new lock rings **8** with every repair.

## 18.4.42 Premounting the kickstarter shaft

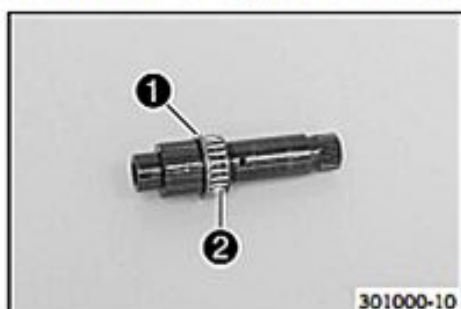

- Mount washer 1 and needle bearing 2.



- Mount starter wheel 3.
- Mount washer 4 and lock ring 5.

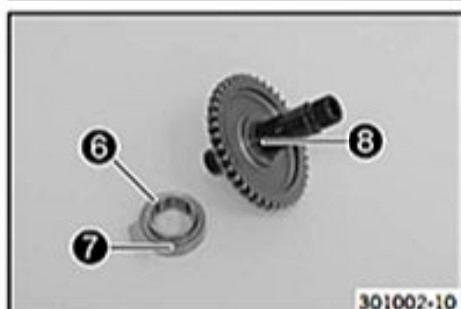

- Mount kickstarter ratchet wheel 6.
- ✓ Marking 7 points to drill hole 8.



- Position spring 9 and mount washer 10.



- Mount driving hub 11.

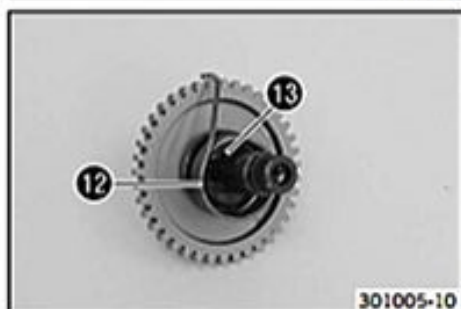

- Position kickstarter spring 12 and hook it into drill hole 13.

## 18.4.43 Checking the starter drive

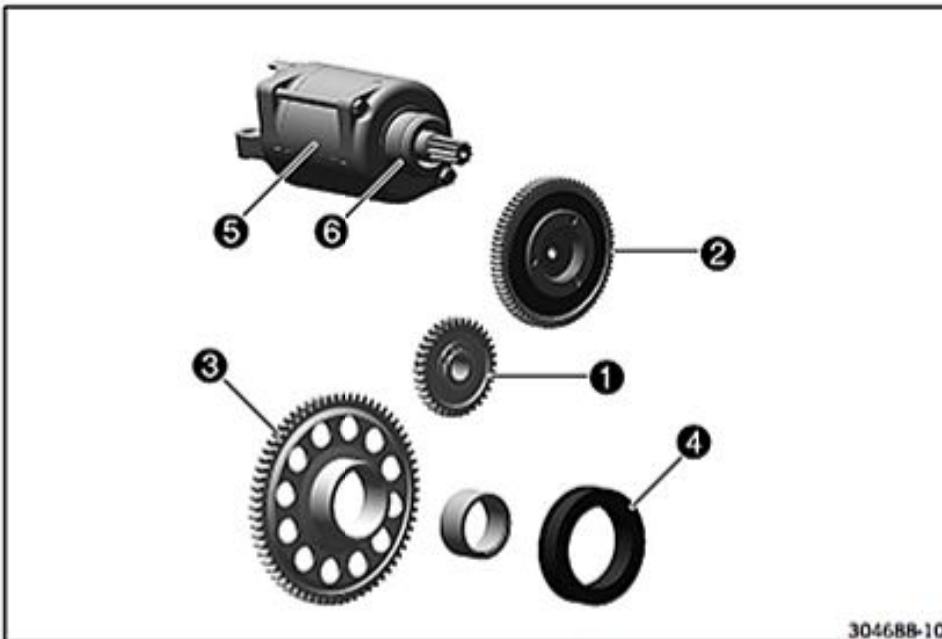

304688-10

- Check the gear mesh and bearing of starter idler gear **1** for damage and wear.
  - If there is damage or wear:
    - Change the starter idler gear.
- Check the gear mesh and bearing of torque limiter **2** for damage and wear.
  - If there is damage or wear:
    - Change the torque limiter.
- Check the gear mesh and bearing of freewheel gear **3** for damage and wear.
  - If there is damage or wear:
    - Change the freewheel gear or bearing.
- Check freewheel **4** for damage and wear when it is disassembled.
  - If there is damage or wear:
    - Change the freewheel.
- Check the gear mesh of starter motor **5** for damage and wear.
  - If there is damage or wear:
    - Change the starter motor.
- Change the O-ring **6** of the starter motor.
- Connect the negative cable of a 12 volt power supply to the housing of the starter motor. Connect the positive cable of the power supply briefly with connector of the starter motor.
  - If the starter motor does not turn when the circuit is closed:
    - Change the starter motor.

## 18.4.44 Removing the freewheel

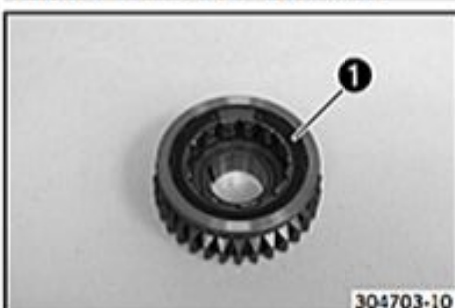

304703-10

- Press expansion ring **1** together with suitable pliers and take off.

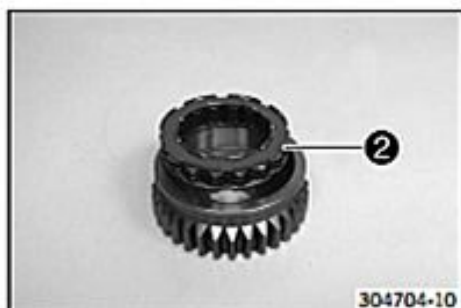

- Take the freewheel ② out of the primary gear.

#### 18.4.45 Checking the freewheel

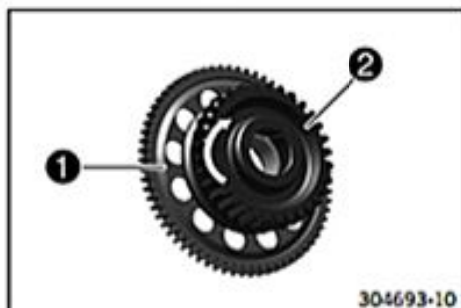

- Insert freewheel gear ① into primary gear ②, turning the primary gear clockwise; do not wedge!
- Check the locking action of freewheel gear ①.
  - If the primary gear does not turn clockwise or if it does not lock counterclockwise:
    - Remove the freewheel. (↖ p. 185)
    - Turn the freewheel 180°.
    - Install the freewheel. (↖ p. 186)

#### 18.4.46 Installing the freewheel

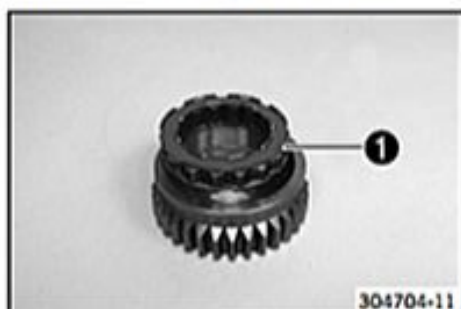

- Thoroughly oil all parts.
- Push the freewheel ① into the primary gear.



#### Info

Note the direction of rotation.

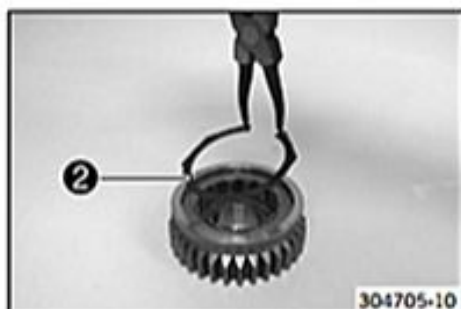

- Mount spreader ring ②.

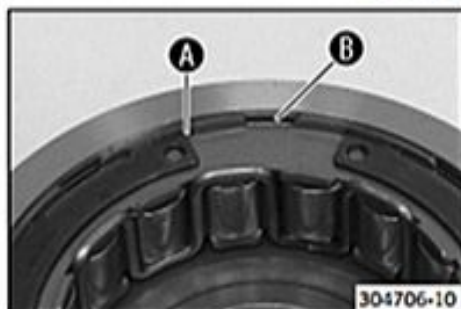

- Ensure that all lugs of the spreader ring pass through slots A of the freewheel and engage in groove B of the primary gear.

## 18.5 Engine assembly

## 18.5.1 Installing the crankshaft

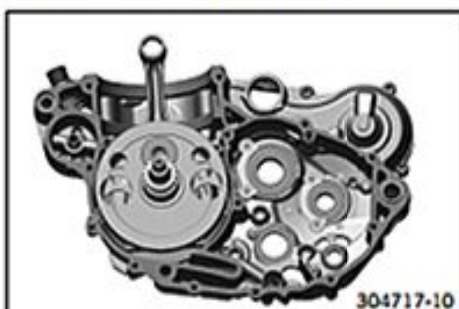

- Tighten the right section of the engine case in the engine assembly stand.
- Heat the crankshaft bearing.

## Guideline

80 °C (176 °F)



## Info

Do not damage the seal ring.

- Mount the special tool on the clutch end of the crankshaft.

Mounting sleeve (78029005000) (☛ p. 320)

- Push the crankshaft all the way into the bearing seat of the right section of the engine case.
- Remove the special tool.

## 18.5.2 Installing the transmission shafts



- Lubricate all bearings.
- Slide both transmission shafts into the bearing seats.



## Info

Make sure not to misplace the washers.



- Mount lock ring ①.

## 18.5.3 Installing the shift forks

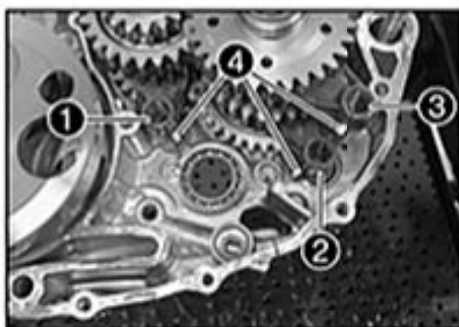

- Thoroughly oil all parts.
- Shift fork ① has a smaller inside diameter; mount this in the shift groove of the main shaft.
- Mount shift fork ② in the lower shift groove of the countershaft.
- Mount shift fork ③ in the upper shift groove of the countershaft.
- Slide on shift rollers ④.



## Info

Fix the shift rollers to the shift forks with grease.



## 18.5.4 Installing the shift drum



- Push shift drum **1** into the bearing seat.
- Put shift forks **2** in the shift drum.

**Info**

Do not misplace the shift rollers.

## 18.5.5 Installing the shift rails

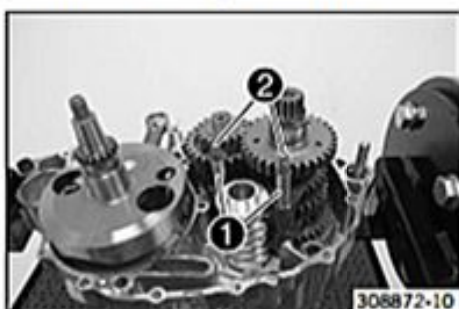

- Install shift rails **1** together with upper springs **2** and lower springs.

**Info**

Fix the springs in the shift rails with grease.

## 18.5.6 Installing the left engine case

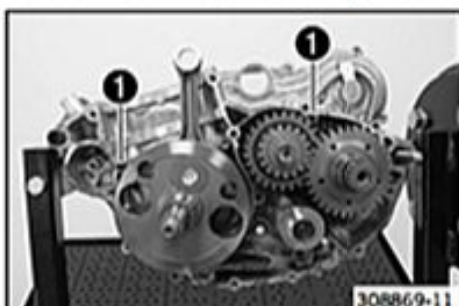

- Mount dowels **1** onto the left section of the engine case.
- Grease the sealing surfaces. Apply the sealing compound to the left section of the engine case.

Loctite® 5910

**Info**

To prevent sealing compound from entering into the oil channels, dowels **1** must be mounted first.

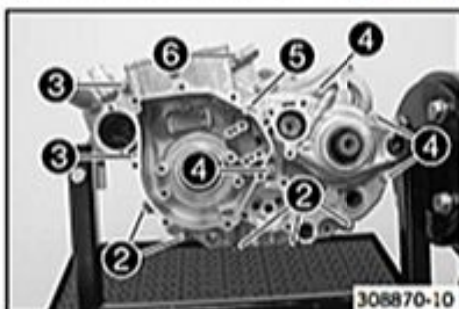

- Mount the left engine casing. If necessary, strike it lightly with a rubber mallet.

**Info**

Do not use the screws to pull the two sections of the engine case together.

- Mount screws **2** but do not tighten them yet.

Guideline

Screw, engine case	M6x40	10 Nm (7.4 lbf ft)
--------------------	-------	--------------------

- Mount screws **3** but do not tighten them yet.

Guideline

Screw, engine case	M6x60	10 Nm (7.4 lbf ft)
--------------------	-------	--------------------

- Mount screws **4** but do not tighten them yet.

Guideline

Screw, engine case	M6x75	10 Nm (7.4 lbf ft)
--------------------	-------	--------------------

- Mount screw **5** but do not tighten yet.

Guideline

Screw, engine case	M6x80	10 Nm (7.4 lbf ft)
--------------------	-------	--------------------

- Mount screw **6** and tighten all screws in a crisscross pattern.

Guideline

Screw, engine case	M6x85	10 Nm (7.4 lbf ft)
--------------------	-------	--------------------



- Mount the O-ring on the countershaft.
- Lightly grease and mount spacer 7.

## 18.5.7 Installing the freewheel gear

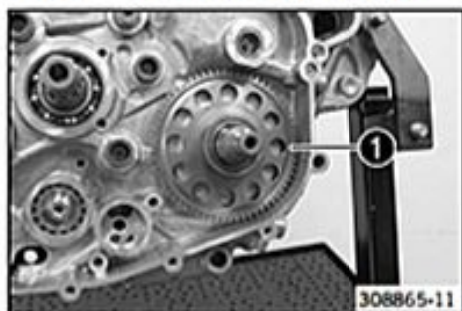

- Mount freewheel gear 1.

## 18.5.8 Installing the primary gear

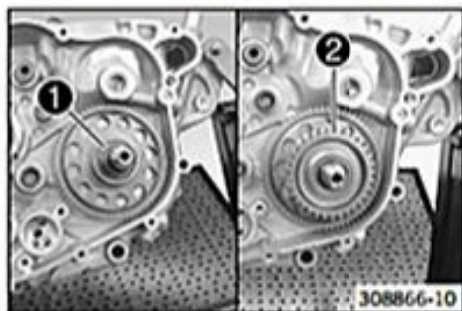

- Mount woodruff key 1.
- Degrease the cone and thinly apply thread locker to it.

Loctite® 648™

- Mount primary gear 2.

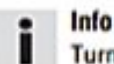

### Info

Turn the freewheel gear to ease engagement.

## 18.5.9 Installing the force pump

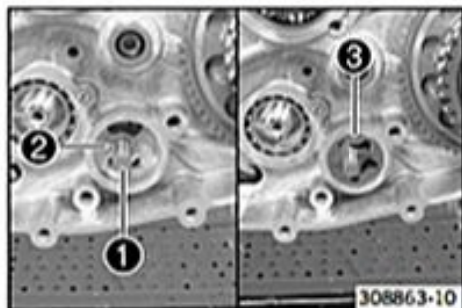

- Oil the oil pump shaft, internal rotor and external rotor before assembly.

Engine oil (SAE 10W/50) (☞ p. 310)

- Mount oil pump shaft 1.
- Mount pin 2. Slide on the internal rotor with the marking facing outward.
- Mount external rotor 3 with the marking facing inward.



### Info

The marking should not be visible after installation.

- Position oil pump cover 4. Mount and tighten screws 5.

### Guideline

Screw, oil pump cover	M6	10 Nm (7.4 lbf ft)	Loctite® 243™
-----------------------	----	-----------------------	---------------

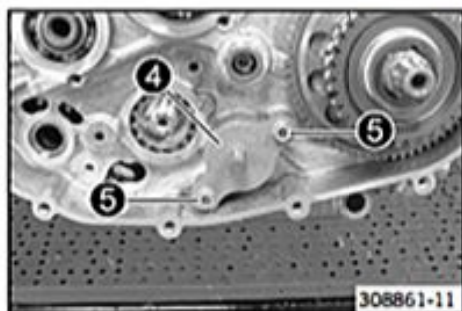

## 18.5.10 Installing the oil pump gear wheels

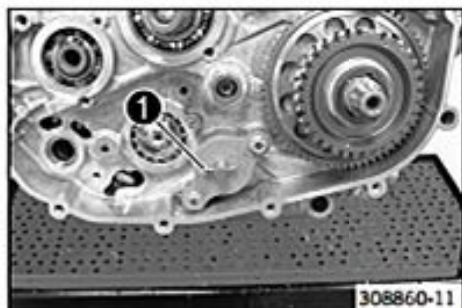

- Insert pin ①.

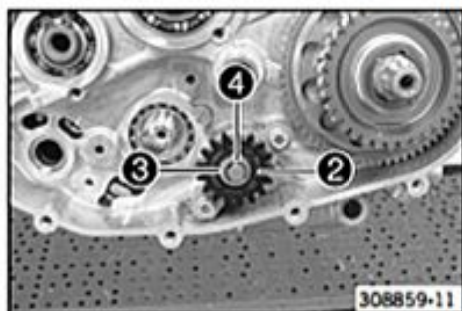

- Position oil pump gear wheel ②.
- Position washers ③.
- Mount lock washer ④.



- Mount oil pump idler gear ⑤.
- Mount washer ⑥ and lock ring ⑦.
- Crank the oil pump gear wheels and ensure that they can move easily.

## 18.5.11 Installing the locking lever

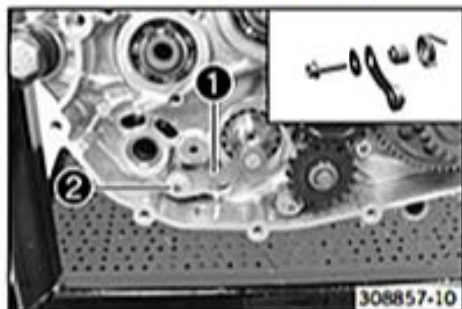

- Mount locking lever ① with the washer, sleeve and spring.
- Mount and tighten screw ②.

## Guideline

Screw, locking lever	M5	6 Nm (4.4 lbf ft)	Loctite® 243™
----------------------	----	----------------------	---------------

## 18.5.12 Installing the shift drum locating unit

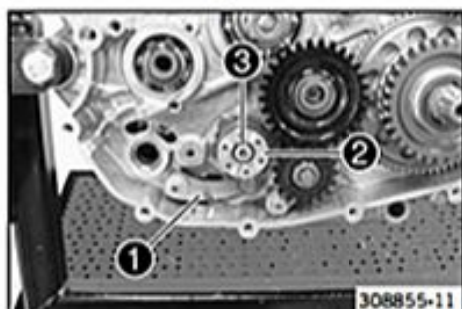

- Push away locking lever ① from the shift drum locating unit and position the shift drum locating unit ②.

**i** Info

The flat areas of the shift drum locating unit are not symmetric.

- Relieve tension from the locking lever.
- Mount and tighten screw ③.

## Guideline

Screw, shift drum locating	M6	10 Nm (7.4 lbf ft)	Loctite® 243™
----------------------------	----	-----------------------	---------------



## 18.5.13 Installing the shift shaft

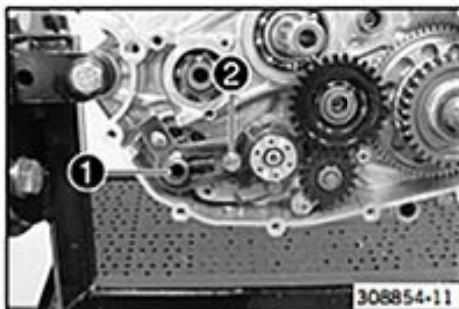

- Slide shift shaft **1** with the washer into the bearing seat.
- Push sliding plate **2** away from the shift drum locating unit. Insert the shift shaft all the way.
- Let sliding plate **2** engage in the shift drum locating unit.
- Shift through the transmission.

## 18.5.14 Installing the kickstarter idler gear



- Slide on kickstarter idler gear **1** with the collar facing the engine case.
- Slide on the disk. Mount the lock ring.

## 18.5.15 Installing the kickstarter shaft

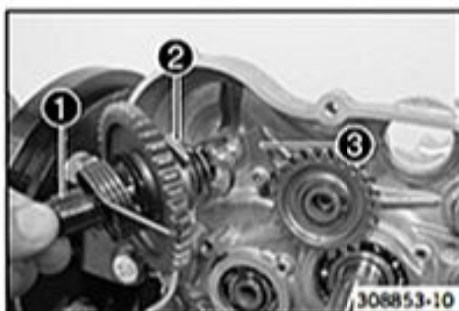

- Slide the premounted kickstarter shaft **1** into the bearing seat.

**Info**

The kickstarter ratchet wheel **2** should not be in contact with stop plate **3**.

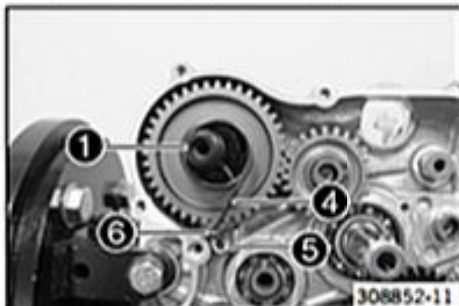

- Turn kickstarter shaft **1** clockwise all the way.
- Pretension kickstarter spring **4**, and attach and position spring hanger **5**.
- Mount and tighten screw **6**.

## Guideline

Screw, kick starter spring hanger	M6	10 Nm (7.4 lbf ft)	Loctite® 243™
-----------------------------------	----	-----------------------	---------------

## 18.5.16 Installing the starter idler gear



- Slide on starter idler gear **1** with the collar facing the engine case.
- Slide on the disk. Mount the lock ring.

## 18.5.17 Installing the torque limiter



- Position the washer.
- Slide on torque limiter **1**. Mount and tighten the screw with the washer.

## Guideline

Screw, torque governor	M6	10 Nm (7.4 lbf ft)	Loctite® 243™
------------------------	----	-----------------------	---------------

## 18.5.18 Installing the outer clutch hub



- Mount collar bushing **1** and both needle bearings **2**.

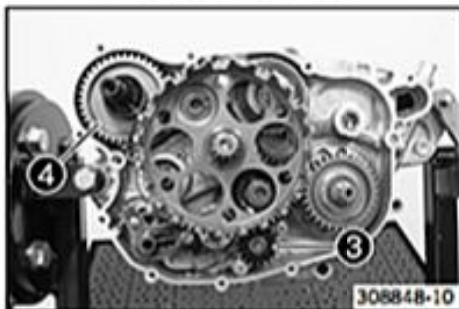

- Slide the outer clutch hub onto the gearbox main shaft. Turn oil pump gear wheel **3** and kick starter gear **4** until the teeth of the outer clutch hub mesh.

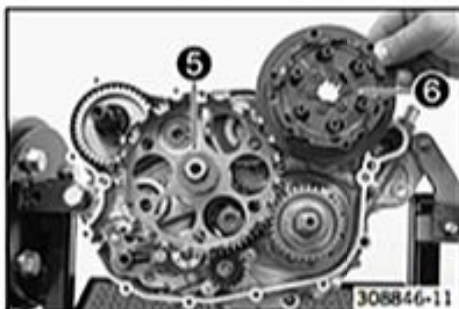

- Slide on washer **5** and inner clutch hub **6**.

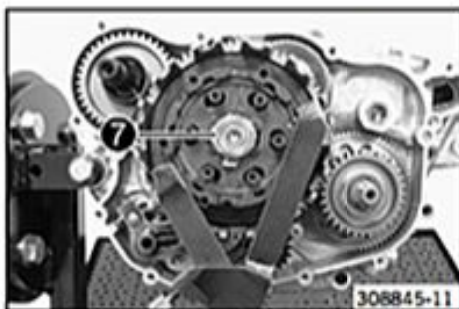

- Position the new lock washer and mount nut **7**. Tighten the nut, holding the inner clutch hub with a special tool.

## Guideline

Nut, inner clutch hub	M18x1.5	80 Nm (59 lbf ft)
-----------------------	---------	-------------------

Clutch holder (51129003000) (☞ p. 315)
--

- Secure the nut with the lock washer.

## 18.5.19 Installing the primary gear nut

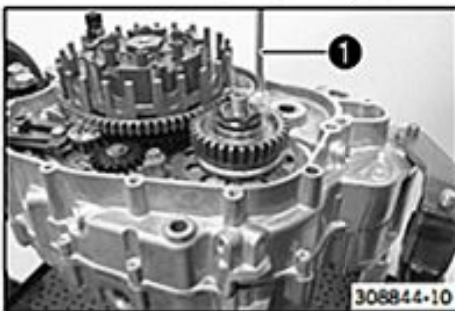

- Lock the outer clutch hub and primary gear using special tool ❶.

Gear quadrant (80029004000) (☞ p. 321)

- Mount and tighten the nut.

## Guideline

Nut, primary gear	M20LHx1.5	100 Nm (73.8 lbf ft)	Loctite® 648™
-------------------	-----------	-------------------------	---------------

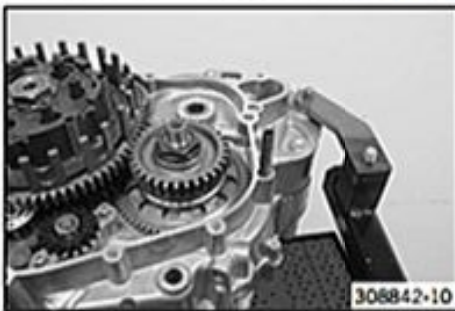

- Position the crankshaft at top dead center (TDC) and block using the special tool.

Locking screw (113080802) (☞ p. 313)

## 18.5.20 Installing the clutch discs

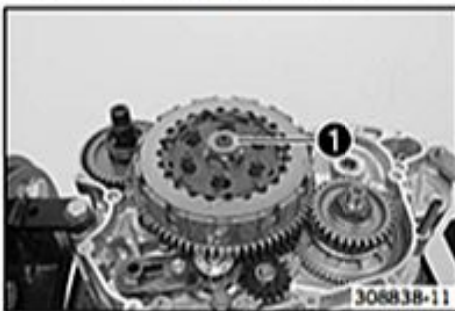

- Thoroughly oil the clutch facing discs.
- Beginning with an intermediate clutch disc, alternately insert all other clutch facing discs and intermediate clutch discs into the outer clutch hub.
- Mount pressure piece ❶.

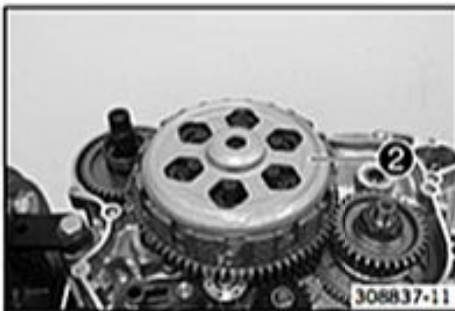

- Position pressure cap ❷.

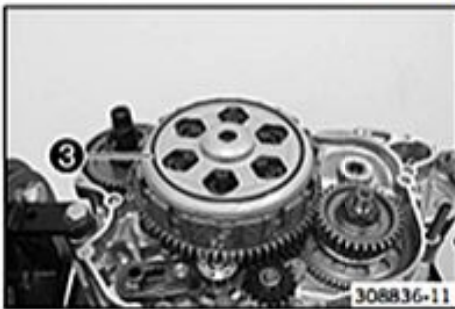

- Mount pretension ring ❸ with the **Top** marking facing up.



- Position spring washer **4**.

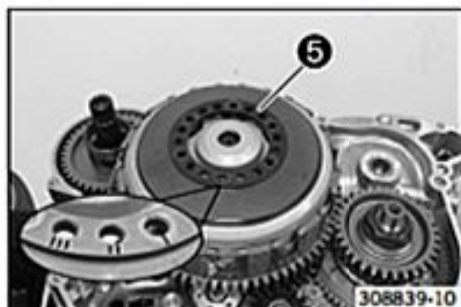

- Position spring retainer **5** with the I marking.



- Install the screws **6** and tighten them diagonally.

## Guideline

Screw, clutch spring retainer	M5	6 Nm (4.4 lbf ft)
-------------------------------	----	-------------------



- Using a straightedge and the special tool, check the spring washer for distortion.

Feeler gauge (59029041100) (☞ p. 316)	
---------------------------------------	--

Spring washer distortion	0... 0.10 mm (0... 0.0039 in)
--------------------------	-------------------------------

- If the specified value is not reached:
  - Remove screws **6** and mount spring retainer with marking II.

- Using a straightedge and the special tool, check the spring washer for distortion.

Feeler gauge (59029041100) (☞ p. 316)	
---------------------------------------	--

Spring washer distortion	0... 0.10 mm (0... 0.0039 in)
--------------------------	-------------------------------

- If the specified value is not reached:
  - Remove screws **6** and mount spring retainer with marking III.

- Using a straightedge and the special tool, check the spring washer for distortion.

Feeler gauge (59029041100) (☞ p. 316)	
---------------------------------------	--

Spring washer distortion	0... 0.10 mm (0... 0.0039 in)
--------------------------	-------------------------------

- If the specified value is not reached:
  - Change the clutch facing discs.



## 18.5.21 Installing the clutch cover

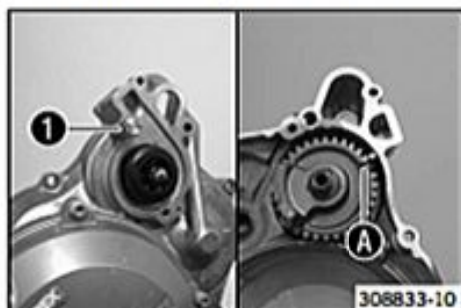

- Position the balancer shaft with special tool **1**.

Fixing drift (78129032000) (☞ p. 321)	
---------------------------------------	--

- ✓ Marking **A** and the special tool are aligned.

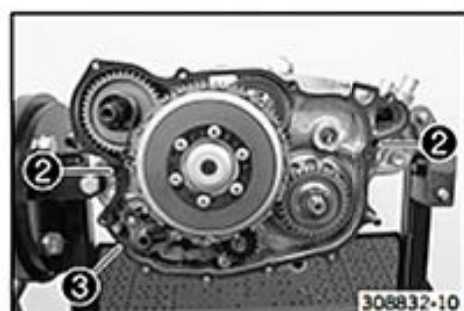

- Mount dowels ②. Put the new clutch cover gasket ③ in place.

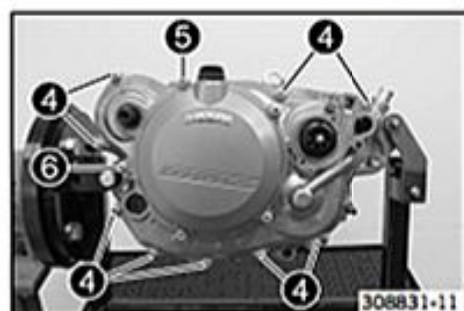

- Mount the clutch cover.
- Mount screws ④ and tighten once all of the clutch cover screws have been mounted.

## Guideline

Screw, clutch cover	M6x25	10 Nm (7.4 lbf ft)
---------------------	-------	--------------------

- Mount screw ⑤ and tighten once all of the clutch cover screws have been mounted.

## Guideline

Screw, clutch cover	M6x55	10 Nm (7.4 lbf ft)
---------------------	-------	--------------------

- Mount screw ⑥ and tighten all screws in a crisscross pattern.

## Guideline

Screw, clutch cover	M6x30	10 Nm (7.4 lbf ft)
---------------------	-------	--------------------

- Remove the special tool.

Fixing drift (78129032000) (☛ p. 321)
---------------------------------------

## 18.5.22 Installing the water pump cover

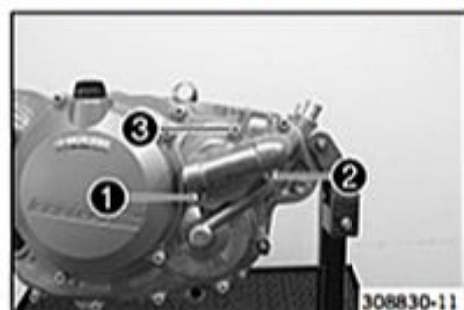

- Put the water pump cover seal in place.
- Mount the water pump cover. Mount screw ① with the sealing washer but do not tighten yet.

## Guideline

Screw, water pump cover	M6x25	10 Nm (7.4 lbf ft)
-------------------------	-------	--------------------

- Mount screw ② but do not tighten yet.

## Guideline

Screw, water pump cover	M6x25	10 Nm (7.4 lbf ft)
-------------------------	-------	--------------------

- Mount screw ③ and tighten all screws in a crisscross pattern.

## Guideline

Screw, water pump cover	M6x55	10 Nm (7.4 lbf ft)
-------------------------	-------	--------------------

## 18.5.23 Installing the suction pump

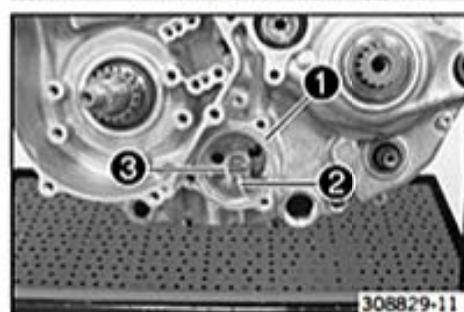

- Oil the internal rotor and external rotor before mounting.
- Insert O-ring ①.
- Position pin ② into the oil pump shaft from above.
- Position pin ③.

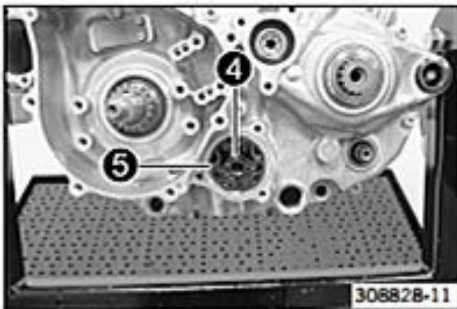

- Mount internal rotor 4 and external rotor 5.
- ✓ The rounded sides of the external rotor face the engine case.

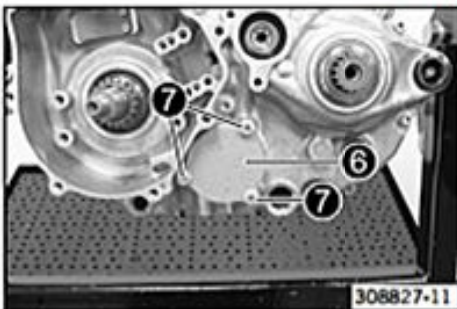

- Position oil pump cover 6. Mount and tighten screws 7.

**Guideline**

Screw, oil pump cover	M5	6 Nm (4.4 lbf ft)	Loctite® 243™
-----------------------	----	----------------------	---------------

### 18.5.24 Installing the ignition pulse generator

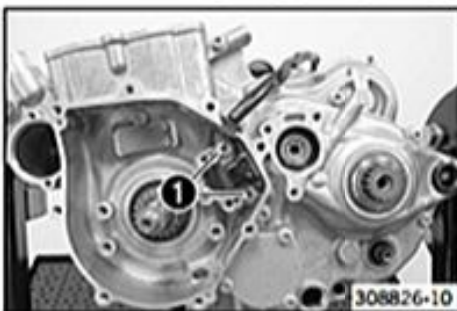

- Position the ignition pulse generator.

**Info**

Use the outer drill hole pair.

- Mount and tighten screws 1.

**Guideline**

Screw, ignition pulse generator	M5	6 Nm (4.4 lbf ft)	Loctite® 243™
---------------------------------	----	----------------------	---------------

- Position the cable and insert the cable sleeve into the engine case.

### 18.5.25 Installing the timing chain

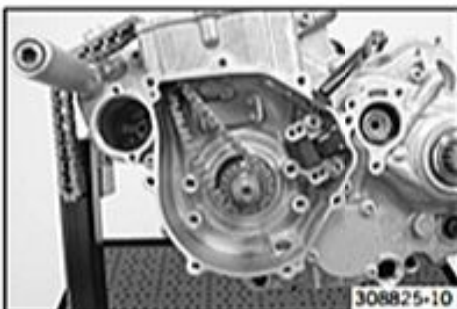

- Thread in the timing chain and place it over the timing chain sprocket.

**Info**

If the timing chain was used before, ensure it is running in the correct direction.

### 18.5.26 Installing the timing chain securing guide



- Position the timing chain securing guide. Mount and tighten screws 1.

**Guideline**

Screw, timing chain securing guide	M6	10 Nm (7.4 lbf ft)	Loctite® 243™
------------------------------------	----	-----------------------	---------------

## 18.5.27 Installing the timing chain tensioning rail



- Thread in the timing chain tensioning rail from the top. Mount and tighten screw ①.

Guideline

Screw, timing chain tensioning rail	M6	10 Nm (7.4 lbf ft)	Loctite® 243™
-------------------------------------	----	-----------------------	---------------

## 18.5.28 Installing the timing chain guide rail

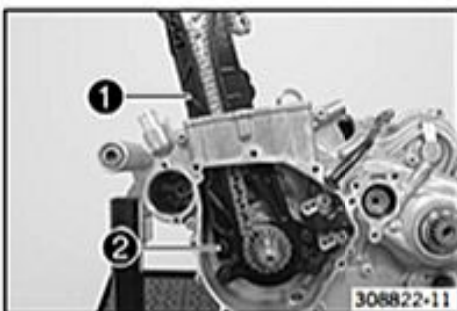

- Slip in the timing chain guide rail ① from above. Mount and tighten screw ②.

Guideline

Screw, timing chain guide rail	M6	10 Nm (7.4 lbf ft)	Loctite® 243™
--------------------------------	----	-----------------------	---------------

## 18.5.29 Installing the rotor



- Mount the woodruff key.
- Mount the rotor.
- Mount the spring washer and nut. Tighten the nut.

Guideline

Nut, rotor	M12x1	60 Nm (44.3 lbf ft)
------------	-------	------------------------

## 18.5.30 Installing the piston



- Move the joints of the compression ring and oil scraper ring so they are offset by 180°.
- Place the oiled piston on the cylinder. Compress the piston rings using the special tool.

Piston ring mounting tool (60029015000) (☛ p. 316)



- Tap lightly on the piston ring mounting tool from above with a plastic hammer so that it lies flush with the cylinder.
- ✓ The special tool must press the piston rings together properly and lie flush with the cylinder.



- Carefully tap the piston into the cylinder using the handle of the hammer.
- ✓ The piston rings should not catch or they will be damaged.



- Mount dowels ① and put cylinder base gasket ② in place.



- Ensure that piston mark ③ faces toward the exhaust side.



- Cover the engine case opening with a cloth. Thread the timing chain through the chain shaft. Mount the piston pin.

**Info**

In order to present them more clearly, the following steps are shown with a removed piston.

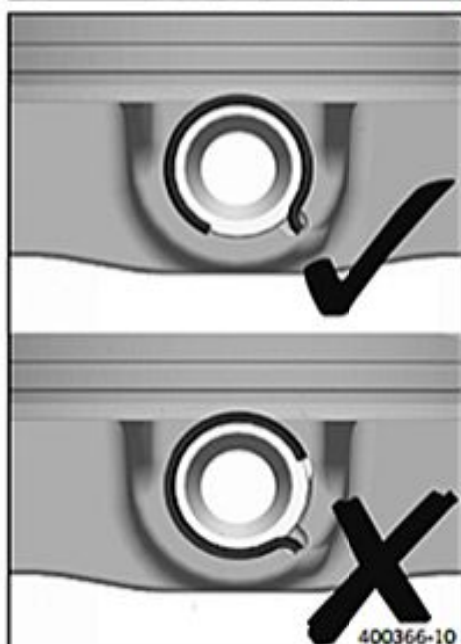

- Position the piston pin retainer.





200084-10

- Insert the special tool and press it forcefully to the piston.
- Turn the special tool counterclockwise, thereby pushing the piston pin retainer into the groove.

Insert for piston pin retainer (77329030100) (☛ p. 319)

- Ensure that the piston pin retainer is seated properly on both sides.



308817-11

- Remove the cloth. Keep the timing chain taut.
- Carefully push the cylinder downward, letting the dowels engage.

### 18.5.31 Installing the cylinder head

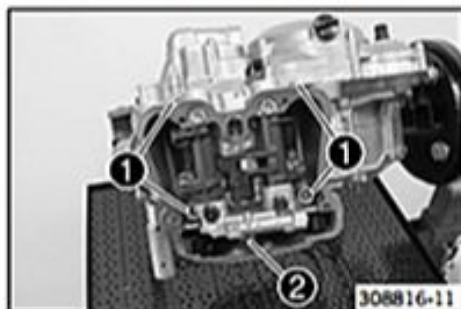

308816-11

- Mount the dowels. Put the new cylinder head gasket in place.
- Put the cylinder head in place.
- Put on the cylinder head bolt washers.
- Mount cylinder head bolts ❶ and tighten in a crisscross pattern.

Guideline

Screw, cylinder head	M10x1.25	Tightening sequence: Tighten diagonally, beginning with the rear screw on the timing chain shaft. Step 1 10 Nm (7.4 lbf ft) Step 2 30 Nm (22.1 lbf ft) Step 3 50 Nm (36.9 lbf ft)	Lubricated with engine oil
----------------------	----------	---	----------------------------

- Mount and tighten screw ❷.

Guideline

Screw, cylinder head	M6	10 Nm (7.4 lbf ft)
----------------------	----	--------------------

## 18.5.32 Installing the camshaft

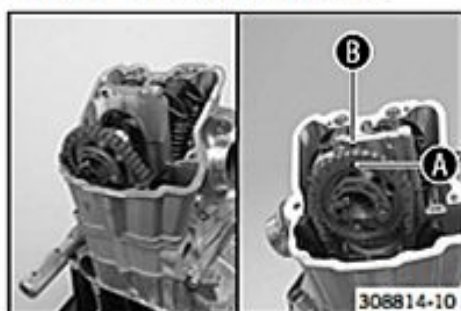

- Place the timing chain over the camshaft gear. Push the camshaft into the bearing seats.

✓ The markings **A** on the camshaft and **B** of the cylinder head are lined up with each other.

**Info**

Make sure that the crankshaft is at top dead center.

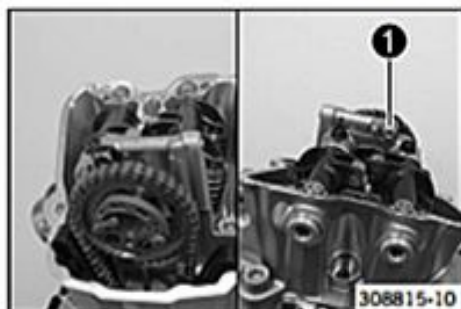

- Position the camshaft support plate. Mount and tighten screw **1**.

## Guideline

Screw, camshaft bearing support	M6	10 Nm (7.4 lbf ft)	Loctite® 243™
---------------------------------	----	--------------------	---------------

## 18.5.33 Installing the timing chain tensioner

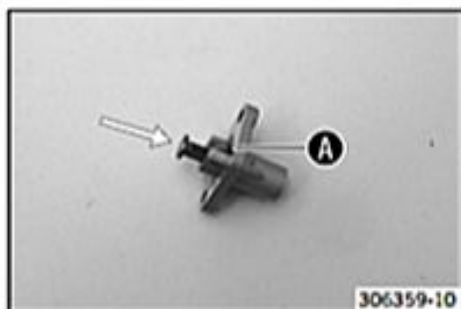

- Activate release **A** and push the timing chain tensioner all the way back.



- Position the timing chain tensioner with the gasket.

- Mount and tighten screws **1**.

## Guideline

Screw, timing chain tensioner	M6	10 Nm (7.4 lbf ft)
-------------------------------	----	--------------------



- Mount and tighten screw plug **2** with washer **3** and spring **4**.

## Guideline

Plug, timing chain tensioner	M8x1	8 Nm (5.9 lbf ft)
------------------------------	------	-------------------

## 18.5.34 Checking the valve clearance



308806-11

- Remove special tool ①.

Locking screw (113080802) (☞ p. 313)

- Crank over the engine repeatedly.
- Position the engine at ignition top dead center. (☞ p. 148)



308807-10

- Check the valve clearance at all valves between the valve and rocker arm.

### Guideline

Valve clearance	
Exhaust at: 20 °C (68 °F)	0.12... 0.17 mm (0.0047... 0.0067 in)
Intake at: 20 °C (68 °F)	0.10... 0.15 mm (0.0039... 0.0059 in)

Feeler gauge (59029041100) (☞ p. 316)

- If the valve clearance does not meet specifications:
  - Adjust the valve clearance. (☞ p. 201)

- Remove the special tool.

Locking screw (113080802) (☞ p. 313)

- Mount and tighten screw ②.

### Guideline

Plug, crankshaft location	M8	10 Nm (7.4 lbf ft)
---------------------------	----	--------------------



308805-11

## 18.5.35 Adjusting the valve clearance

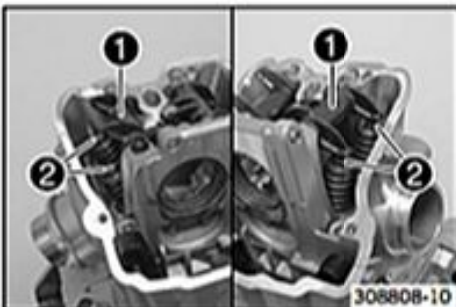

308808-10

- Remove the timing chain tensioner. (☞ p. 149)
- Remove the camshaft. (☞ p. 149)
- Raise rocker arm ① on the outside.
- Remove shims ② and set down in the position in which they were installed.
- Correct the shims according to the findings from checking the valve clearance.
- Insert suitable shims.
- Install the camshaft. (☞ p. 200)
- Install the timing chain tensioner. (☞ p. 200)
- Check the valve clearance. (☞ p. 201)

## 18.5.36 Installing the alternator cover

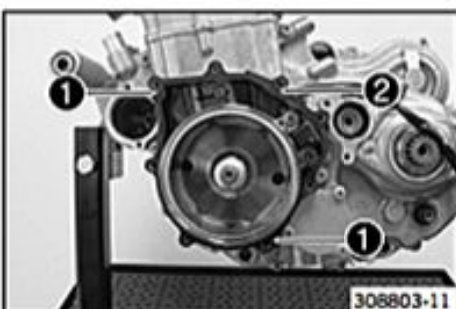

308803-11

- Mount locating pins ①. Position alternator cover gasket ②.

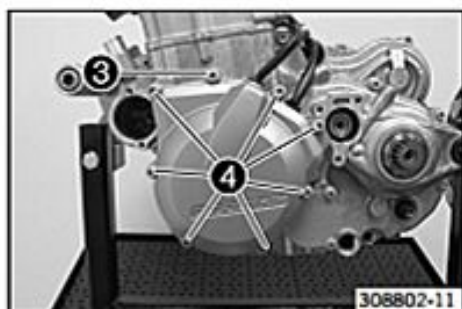

- Position the alternator cover. Mount screws ③ with washer and tighten after all of the alternator cover screws have been mounted.

Guideline

Screw, alternator cover	M6x25	10 Nm (7.4 lbf ft)
-------------------------	-------	--------------------

- Mount screws ④ and tighten all screws in a crisscross pattern.

Guideline

Screw, alternator cover	M6x25	10 Nm (7.4 lbf ft)
-------------------------	-------	--------------------

### 18.5.37 Installing the valve cover



- Position the valve cover seal.
- Position the valve cover. Mount and tighten screws ①.

Guideline

Screw, valve cover	M6	10 Nm (7.4 lbf ft)
--------------------	----	--------------------

### 18.5.38 Installing the spark plug



- Mount and tighten the spark plug with the special tool.

Guideline

Spark plug	M12x1.25	15... 20 Nm (11.1... 14.8 lbf ft)
------------	----------	---

Spark plug wrench (75029172000) (☛ p. 319)

### 18.5.39 Installing the kickstarter



- Position the kickstarter. Mount and tighten screw ①.

Guideline

Screw, kick starter	M8	25 Nm (18.4 lbf ft)	Loctite® 2701™
---------------------	----	------------------------	----------------

### 18.5.40 Installing the starter motor



- Grease the O-ring. Position the starter motor.

Long-life grease (☛ p. 311)

- Mount and tighten screws ①.

Guideline

Screw, starter motor	M6	10 Nm (7.4 lbf ft)
----------------------	----	--------------------

## 18.5.41 Installing the oil filter

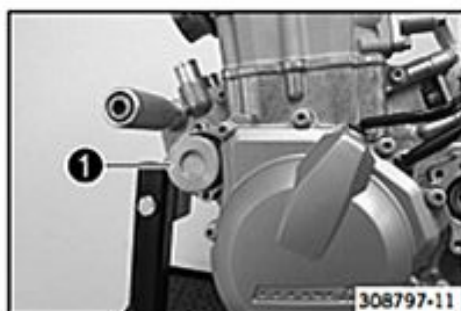

- Tilt the motorcycle to one side and fill the oil filter housing to about 1/3 full with engine oil.
- Insert oil filter **1** into the oil filter housing.

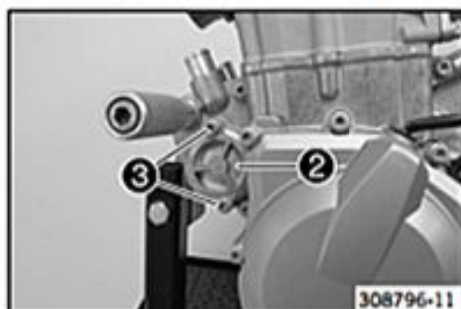

- Oil the O-ring of the oil filter cover.
- Mount oil filter cover **2**.
- Mount and tighten screws **3**.

## Guideline

Screw, oil filter cover	M5	6 Nm (4.4 lbf ft)
-------------------------	----	-------------------

## 18.5.42 Installing the clutch push rod



- Mount clutch push rod **1**.

## 18.5.43 Installing the oil screen



- Mount and tighten engine oil screen plug **1** with the O-ring.

## Guideline

Screw plug, engine oil screen	M20x1.5	15 Nm (11.1 lbf ft)
-------------------------------	---------	------------------------

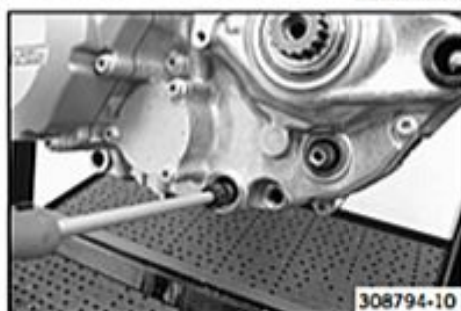

- Push the oil screen with O-rings onto a pin wrench.
- Push the pin wrench through the opening into the drill hole of the opposite engine case wall and push the oil screen as far as possible into the engine case.



308791-10

- Mount and tighten engine oil screen plug ② with the O-ring.

## Guideline

Screw plug, engine oil screen	M20x1.5	15 Nm (11.1 lbf ft)
-------------------------------	---------	------------------------

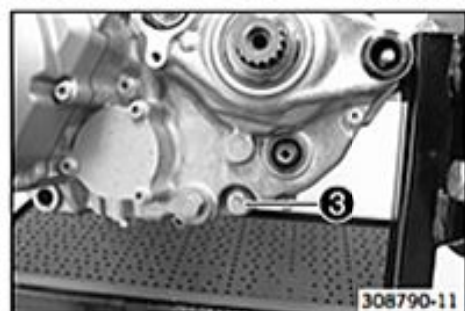

308790-11

- Mount and tighten the oil drain plug ③ with the magnet and the new seal ring.

## Guideline

Oil drain plug with magnet	M12x1.5	20 Nm (14.8 lbf ft)
----------------------------	---------	------------------------

## 18.5.44 Removing the engine from the engine assembly stand



308789-10

- Mount the kick starter.
  - Remove the screw connection from the special tool.
- |   |
|---|
| Engine bracket (78029002000) (☛ p. 320) |
|---|
- Remove the engine from the engine assembly stand.



## Info

Have an assistant help you or use a motorized hoist.

## 19.1 Checking/correcting the fluid level of the hydraulic clutch

- i Info**  
The fluid level rises with increased wear of the clutch lining discs.

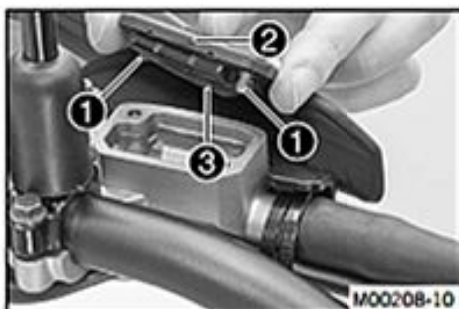

- Move the clutch fluid reservoir mounted on the handlebar to a horizontal position.
- Remove screws **1**.
- Remove cover **2** with membrane **3**.
- Check the fluid level.

Fluid level below container rim	4 mm (0.16 in)
---------------------------------	----------------

- If the fluid level does not meet specifications:
  - Correct the fluid level of the hydraulic clutch.

Brake fluid DOT 4 / DOT 5.1 (☞ p. 310)
--

- Position the cover with the membrane. Mount and tighten the screws.

- i Info**  
Clean up overflowed or spilled brake fluid immediately with water.

## 19.2 Changing the hydraulic clutch fluid

- Warning**  
**Environmental hazard** Hazardous substances cause environmental damage.

- Oil, grease, filters, fuel, cleaners, brake fluid, etc., should be disposed of as stipulated in applicable regulations.

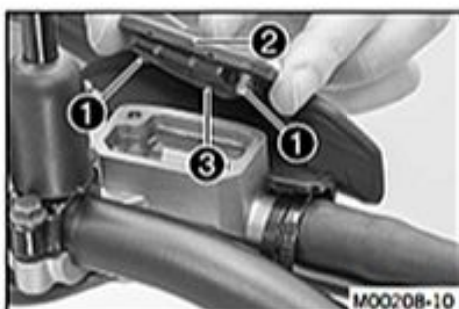

- Move the clutch fluid reservoir mounted on the handlebar to a horizontal position.
- Remove screws **1**.
- Remove cover **2** with membrane **3**.



(EXC EU/AUS, EXC SIX DAYS, EXC Factory Edition, XC-W)

- Fill bleeding syringe **4** with the appropriate hydraulic fluid.

Bleed syringe (50329050000) (☞ p. 314)
--

Brake fluid DOT 4 / DOT 5.1 (☞ p. 310)
--

- On the clutch slave cylinder, remove bleeder screw **5** and mount bleeding syringe **4**.

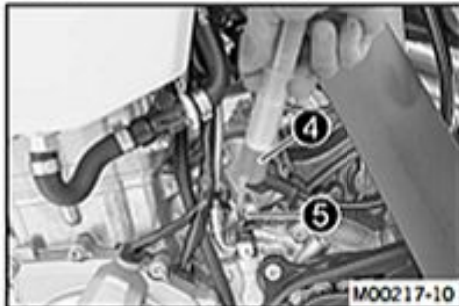

(500 EXC US)

- Fill bleeding syringe **4** with the appropriate hydraulic fluid.

Bleed syringe (50329050000) (☞ p. 314)
--

Brake fluid DOT 4 / DOT 5.1 (☞ p. 310)
--

- On the clutch slave cylinder, remove bleeder screw **5** and mount bleeding syringe **4**.



- Inject the liquid into the system until it escapes from openings ⑥ of the master cylinder without bubbles.
- To prevent overflow, drain fluid occasionally from the master cylinder reservoir.
- Remove the bleeding syringe. Mount and tighten screws bleeder screw.
- Correct the fluid level of the hydraulic clutch.

#### Guideline

Fluid level below container rim	4 mm (0.16 in)
---------------------------------	----------------

- Position the cover with the membrane. Mount and tighten the screws.



## 20.1 Cooling system

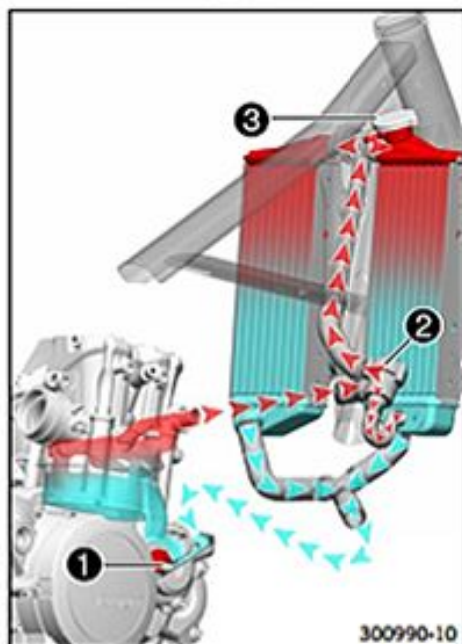

Water pump **1** in the engine circulates the coolant.

The water flow through the radiator is controlled as a function of the coolant temperature. The cooling system is divided into two circuits. In the warming-up phase of the engine, the coolant flows through the small cooling circuit. This heats up the engine quickly. The thermostat **2** warms up and opens the opening to the radiator (large cooling circuit). This keeps the engine temperature constant.

The pressure resulting from the warming of the cooling system is regulated by a valve in radiator cap **3**. This ensures that operating the vehicle at the specified coolant temperature will not result in a risk of malfunctions.

120 °C (248 °F)

Cooling is effected by the air stream.

The lower the speed, the less the cooling effect. Dirty cooling fins also reduce the cooling effect.

The radiator fan provides extra cooling. It is controlled by a thermoswitch.

## 20.2 Checking the antifreeze and coolant level

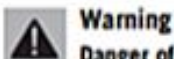
**Warning**

**Danger of scalding** During motorcycle operation, the coolant gets very hot and is under pressure.

- Do not remove the radiator cap, radiator hoses or other cooling system components when the engine is hot. Allow the engine and cooling system to cool down. In case of scalding, rinse immediately with lukewarm water.

**Warning**

**Danger of poisoning** Coolant is poisonous and a health hazard.

- Coolant must not come into contact with the skin, eyes, or clothing. If contact occurs with the eyes, rinse with water immediately and contact a physician. Immediately clean contaminated areas on the skin with soap and water. If fuel is swallowed, contact a physician immediately. Change clothing that is contaminated with coolant. Keep coolant out of reach of children.

**Condition**

The engine is cold.

- Stand the motorcycle upright on a horizontal surface.
- Remove the radiator cap.
- Check antifreeze of coolant.

-25... -45 °C (-13... -49 °F)

- If the antifreeze of the coolant does not meet specifications:
  - Correct the antifreeze of the coolant.

- Check the coolant level in the radiator.

Coolant level **A** above radiator fins. 10 mm (0.39 in)

- If the coolant level does not meet specifications:
  - Correct the coolant level.

Coolant (☞ p. 310)

- Mount the radiator cap.

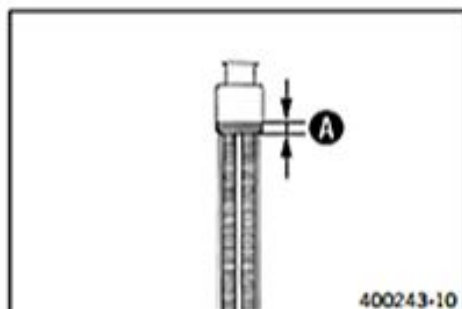

## 20.3 Checking the coolant level

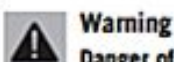

### Warning

**Danger of scalding** During motorcycle operation, the coolant gets very hot and is under pressure.

- Do not remove the radiator cap, radiator hoses or other cooling system components when the engine is hot. Allow the engine and cooling system to cool down. In case of scalding, rinse immediately with lukewarm water.



### Warning

**Danger of poisoning** Coolant is poisonous and a health hazard.

- Coolant must not come into contact with the skin, eyes, or clothing. If contact occurs with the eyes, rinse with water immediately and contact a physician. Immediately clean contaminated areas on the skin with soap and water. If fuel is swallowed, contact a physician immediately. Change clothing that is contaminated with coolant. Keep coolant out of reach of children.

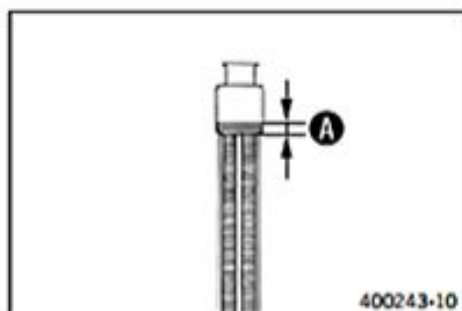

### Condition

The engine is cold.

- Stand the motorcycle upright on a horizontal surface.
- Remove the radiator cap.
- Check the coolant level in the radiator.

Coolant level <b>A</b> above radiator fins.	10 mm (0.39 in)
---	-----------------

- If the coolant level does not meet specifications:
  - Correct the coolant level.

Coolant (☛ p. 310)
--------------------

- Mount the radiator cap.

## 20.4 Draining the coolant



### Warning

**Danger of scalding** During motorcycle operation, the coolant gets very hot and is under pressure.

- Do not remove the radiator cap, radiator hoses or other cooling system components when the engine is hot. Allow the engine and cooling system to cool down. In case of scalding, rinse immediately with lukewarm water.



### Warning

**Danger of poisoning** Coolant is poisonous and a health hazard.

- Coolant must not come into contact with the skin, eyes, or clothing. If contact occurs with the eyes, rinse with water immediately and contact a physician. Immediately clean contaminated areas on the skin with soap and water. If fuel is swallowed, contact a physician immediately. Change clothing that is contaminated with coolant. Keep coolant out of reach of children.

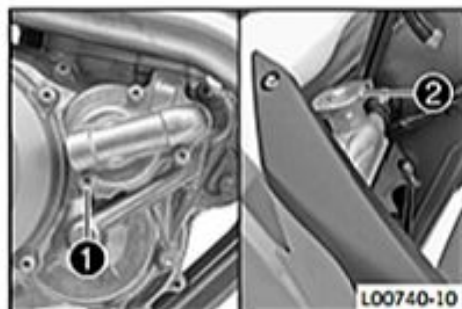

### Condition

The engine is cold.

(EXC EU/AUS, EXC SIX DAYS, EXC Factory Edition, XC-W)

- Position the motorcycle upright.
- Place a suitable container under the water pump cover.
- Remove screw **1**. Take off radiator cap **2**.
- Completely drain the coolant.
- Mount and tighten screw **1** with a new seal ring.

### Guideline

Screw, water pump cover	M6x25	10 Nm (7.4 lbf ft)
-------------------------	-------	-----------------------

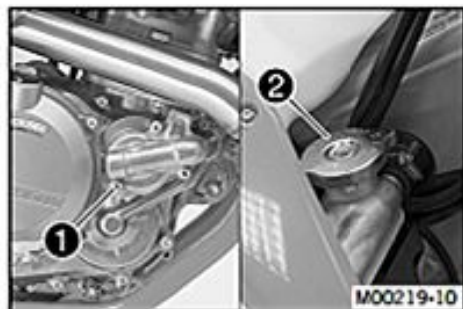

(500 EXC US)

- Position the motorcycle upright.
- Place a suitable container under the water pump cover.
- Remove screw ①. Take off radiator cap ②.
- Completely drain the coolant.
- Mount and tighten screw ① with a new seal ring.

Guideline

Screw, water pump cover	M6x25	10 Nm (7.4 lbf ft)
-------------------------	-------	-----------------------

## 20.5 Refilling coolant

**Warning****Danger of poisoning** Coolant is poisonous and a health hazard.

- Coolant must not come into contact with the skin, eyes, or clothing. If contact occurs with the eyes, rinse with water immediately and contact a physician. Immediately clean contaminated areas on the skin with soap and water. If fuel is swallowed, contact a physician immediately. Change clothing that is contaminated with coolant. Keep coolant out of reach of children.

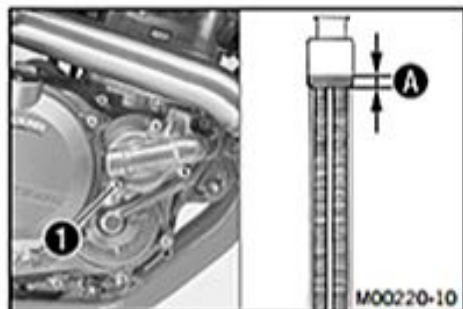
**Main work**

- Make sure that the screw ① is tightened.
- Stand the vehicle upright.
- Pour coolant in up to measurement ① above the radiator fins.

Guideline

10 mm (0.39 in)

Coolant	1.2 l (1.3 qt.)	Coolant (☞ p. 310)
---------	-----------------	--------------------

- Refit the radiator cap.

**Finishing work**

- Take a short test ride.
- Check the coolant level. (☞ p. 208)

## 21.1 Oil circuit

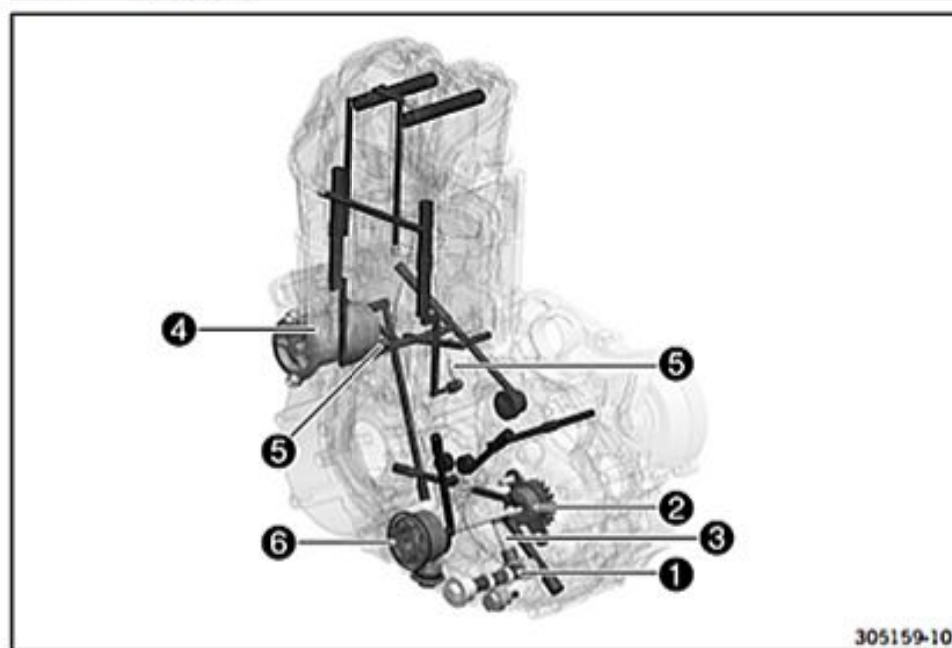

305159-10

1	Oil screen
2	Force pump
3	Oil pressure regulator valve
4	Oil filter
5	Oil nozzle, conrod lubrication
6	Oil nozzle for cam follower lubrication
7	Oil nozzle, piston cooling
8	Oil nozzle for alternator cooling
9	Oil nozzle for clutch lubrication
10	Suction pump
11	Oil channel, transmission lubrication
12	Timing chain tensioner

## 21.2 Checking the engine oil level

**Condition**

The engine is at operating temperature.

**Preparatory work**

- Stand the motorcycle upright on a horizontal surface.

**Main work**

- Check the engine oil level.

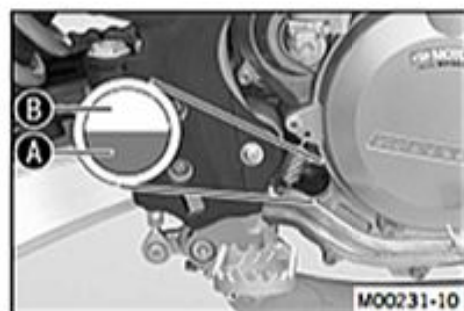

M00231-10

**Info**

After switching off the engine, wait one minute before checking the level.

The engine oil level is between **A** and **B**.

- When the engine oil level is below the **A** marking:
  - Add engine oil. (☛ p. 213)
- When the engine oil level is at or above the **B** marking:
  - Correct the engine oil level.

## 21.3 Changing the engine oil and oil filter, cleaning the oil screens

**Warning**

**Danger of scalding** Engine oil and gear oil get very hot when the motorcycle is ridden.

- Wear appropriate protective clothing and safety gloves. In case of burns, rinse immediately with lukewarm water.

**Warning**

**Environmental hazard** Hazardous substances cause environmental damage.

- Oil, grease, filters, fuel, cleaners, brake fluid, etc., should be disposed of as stipulated in applicable regulations.

**Info**

Drain the engine oil only when the engine is warm.

**Preparatory work**

(EXC AU, EXC Factory Edition, EXC Six Days)

- Remove the engine guard. (☞ p. 63)
- Park the motorcycle on a level surface.

**Main work**

- Place a suitable container under the engine.
- Remove oil drain plug ① with the magnet and seal ring.

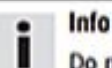

- Remove screw plug ② with the gear oil screen and the O-rings.

**Info**

Do not remove screw A.

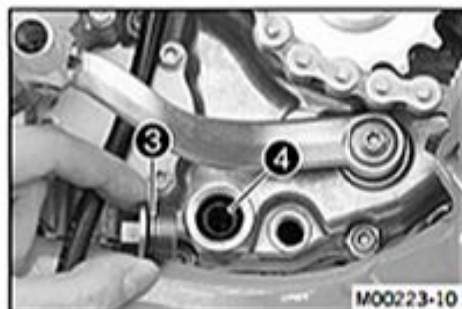

- Remove screw plug ③ with engine oil screen ④ and the O-rings.
- Completely drain the engine oil.
- Thoroughly clean the parts and sealing surfaces.



- Mount and tighten screw plug ② with the gear oil screen and the O-rings.

**Guideline**

Screw plug, gear oil screen	M20x1.5	15 Nm (11.1 lbf ft)
-----------------------------	---------	------------------------

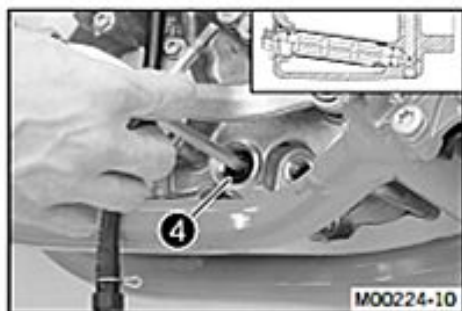

- Position oil screen **4** with the O-rings on a pin wrench.
- Position the pin wrench through the drill hole of the screw plug in the opposite section of the engine case.
- Push the oil screen all the way into the engine case.

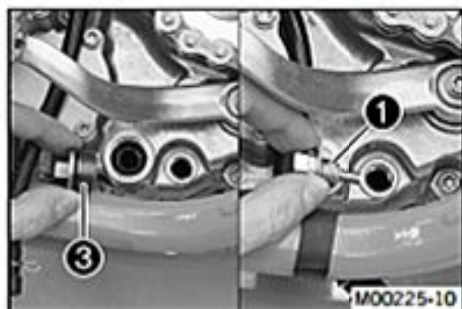

- Mount and tighten screw plug **3** with the O-ring.

**Guideline**

Screw plug, engine oil screen	M20x1.5	15 Nm (11.1 lbf ft)
-------------------------------	---------	------------------------

- Mount and tighten the oil drain plug **1** with the magnet and a new seal ring.

**Guideline**

Oil drain plug with magnet	M12x1.5	20 Nm (14.8 lbf ft)
----------------------------	---------	------------------------

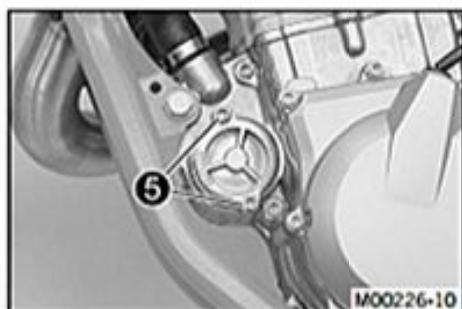

- Remove screws **5**. Remove the oil filter cover with the O-ring.



- Pull oil filter **6** out of the oil filter housing.

Circlip pliers reverse (51012011000) (☞ p. 314)
---

- Completely drain the engine oil.
- Thoroughly clean the parts and sealing surface.



- Lay the motorcycle on its side and fill the oil filter housing to about 1/3 full with engine oil.
- Insert the oil filter into the oil filter housing.
- Oil the O-ring of the oil filter cover and mount it with the oil filter cover **7**.
- Mount and tighten the screws.

**Guideline**

Screw, oil filter cover	M5	6 Nm (4.4 lbf ft)
-------------------------	----	-------------------

- Stand the motorcycle upright.



- Remove the oil filler plug **8** with the O-ring from the clutch cover and fill up with engine oil.

Engine oil	1.5 l (1.6 qt.)	Engine oil (SAE 10W/50) (☞ p. 310)
------------	-----------------	------------------------------------

**Info**

Too little engine oil or poor-quality engine oil results in premature wear to the engine.

- Install and tighten the oil filler plug with O-ring.

**Danger**

**Danger of poisoning** Exhaust gases are toxic and inhaling them may result in unconsciousness and/or death.

- When running the engine, always make sure there is sufficient ventilation, and do not start or run the engine in an enclosed space without an effective exhaust extraction system.

- Start the engine and check that it is oil-tight.

**Finishing work**

(EXC AU, EXC Factory Edition, EXC Six Days)

- Install the engine guard. (☛ p. 63)
- Check the engine oil level. (☛ p. 210)

**21.4 Adding engine oil****Info**

Too little engine oil or poor-quality engine oil results in premature wear to the engine.

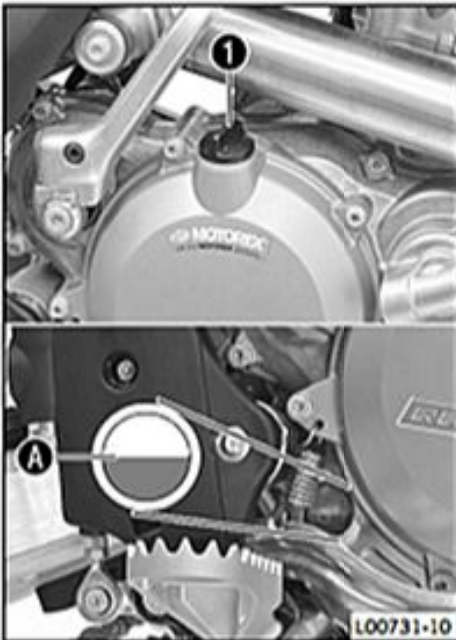
**Main work**

- Remove the oil filler plug ① with the O-ring from the clutch cover.
- Fill engine oil to the middle A of the level viewer.
- Add the same engine oil that was used when the motor was changed.

Engine oil (SAE 10W/50) (☛ p. 310)

**Info**

For optimal performance of the engine oil, do not mix different types of engine oil.

If appropriate, change the engine oil.

- Install and tighten the oil filler plug with O-ring.

**Danger**

**Danger of poisoning** Exhaust gases are toxic and inhaling them may result in unconsciousness and/or death.

- When running the engine, always make sure there is sufficient ventilation, and do not start or run the engine in an enclosed space without an effective exhaust extraction system.

- Start the engine and check that it is oil-tight.

**Finishing work**

- Check the engine oil level. (☛ p. 210)

**21.5 Checking the engine oil pressure****Main work**

- Place a suitable container under the engine.
- Remove screws ①. Take off the oil filter cover with the O-ring.
- Remove the oil filter.

Circlip pliers reverse (51012011000) (☛ p. 314)

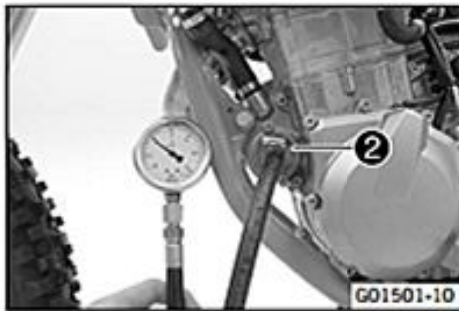

- Position special tool ② with the O-ring. Mount and tighten the screws.

**Guideline**

Screw, oil filter cover	M5	6 Nm (4.4 lbf ft)
-------------------------	----	-------------------

Oil pressure adapter (75029094000) (☛ p. 319)
---

- Connect the pressure tester to the special tool without the T-plate.

Pressure testing tool (61029094000) (☛ p. 317)
--

- Check the engine oil level. (☛ p. 210)



**Danger**

**Danger of poisoning** Exhaust gases are toxic and inhaling them may result in unconsciousness and/or death.

- When running the engine, always make sure there is sufficient ventilation, and do not start or run the engine in an enclosed space without an effective exhaust extraction system.

- Start the engine and let it warm up.
- Check the engine oil pressure.

Engine oil pressure	
Engine oil temperature: 80 °C (176 °F) Engine speed: 1,600 rpm	0.9 bar (13 psi)
Engine oil temperature: 80 °C (176 °F) Engine speed: 6,000 rpm	2.5 bar (36 psi)

- If the measured value is less than the specification:
  - Check the oil pumps for wear. Check all oil channels for free flow.
- Switch off the engine.



**Warning**

**Danger of burns** Some vehicle components get very hot when the machine is driven.

- Wear appropriate protective clothing and safety gloves. In case of burns, rinse immediately with lukewarm water.

- Remove the special tools.
- Insert the oil filter into the oil filter housing.
- Grease the O-ring of the oil filter cover. Mount the oil filter cover.
- Mount and tighten the screws.

**Guideline**

Screw, oil filter cover	M5	6 Nm (4.4 lbf ft)
-------------------------	----	-------------------

**Finishing work**

- Check the engine oil level. (☛ p. 210)



## 22.1 Ignition coil - checking the secondary winding

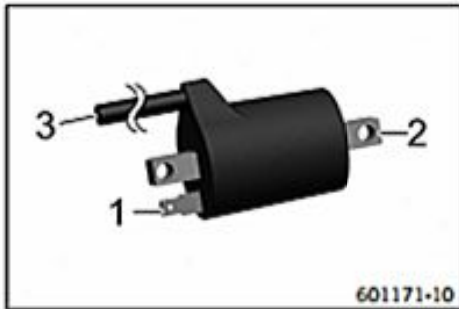

**Condition**

Ignition coil cylinder 1 is disconnected.

Spark plug connector cylinder 1 has been removed.

**Ignition coil cylinder 1 - check the secondary winding resistance**

- $\Omega$  Measure the resistance between the specified points.
  - Ignition coil cylinder 1 pin 2 (→) – Ignition coil cylinder 1 pin 3

Ignition coil	
Secondary winding resistance at: 20 °C (68 °F)	10.8... 16.2 k $\Omega$

- If the displayed value does not correspond to specifications:
  - Change the ignition coil.

## 22.2 Checking the spark plug connector

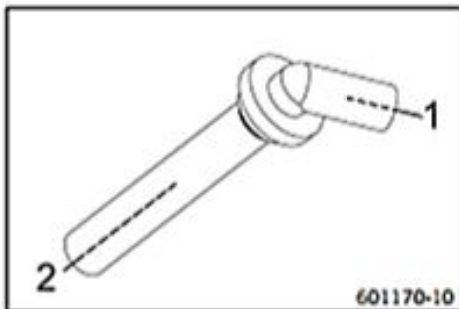

**Condition**

Spark plug connector cylinder 1 has been removed.

- $\Omega$  Measure the resistance between the specified points.
  - Measuring point 1 – Measuring point 2

Spark plug connector	
Resistance at: 20 °C (68 °F)	3.75... 6.25 k $\Omega$

- If the specification is not reached:
  - Change the spark plug connector.

## 22.3 Alternator - checking the stator winding

**Condition**

The stator is disconnected.

**Preparatory work**

- Remove the seat. (↖ p. 93)



**Main work**

**Stator winding, measurement I - check the resistance**

- $\Omega$  Measure the resistance between the specified points.
  - Stator, connector EZ pin 1 – Stator, connector EZ pin 2

Alternator	
Resistance of stator winding at: 20 °C (68 °F)	0.368... 0.552 $\Omega$

- If the value displayed does not meet specifications:
  - Change the stator.

**Stator winding, measurement II - check the resistance**

- $\Omega$  Measure the resistance between the specified points.
  - Stator, connector EZ pin 1 – Stator, connector EZ pin 3

Alternator	
Resistance of stator winding at: 20 °C (68 °F)	0.368... 0.552 $\Omega$

- If the value displayed does not meet specifications:
  - Change the stator.



### Stator winding - check for a short circuit to ground (terminal 31)

- $\Omega$  Measure the resistance between the specified points.  
Stator, connector EZ pin 1 – Measuring point Ground (-)

Resistance	$\approx \Omega$
------------	------------------

- If the value displayed does not meet specifications:
  - Change the stator.

### 22.4 Removing the stator

#### Condition

The alternator cover has been removed.



- Remove screw **1** and take off the cable holder.
- Remove cable support sleeve **2** from the alternator case.
- Remove screws **3**.
- Take the stator out of the alternator cover.

### 22.5 Installing the stator

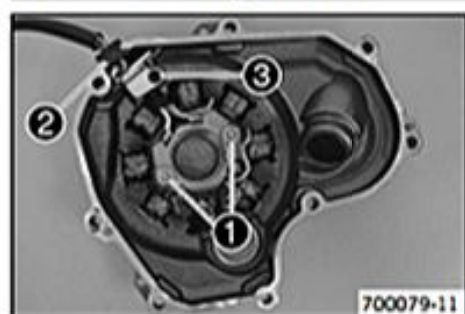

- Position the stator in the alternator cover.
- Mount and tighten screws **1**.

#### Guideline

Screw, stator	M5	6 Nm (4.4 lbf ft)	Loctite® 243™
---------------	----	----------------------	---------------

- Position cable support sleeve **2** in the alternator case.
- Position the cable holder. Mount and tighten screw **3**.

#### Guideline

Screw, cable holder in alternator cover	M4	4 Nm (3 lbf ft)	Loctite® 243™
---	----	--------------------	---------------

### 23.1 Checking the starter motor



#### Condition

The starter motor has been removed.

- Connect the negative cable of a 12 volt power supply to the housing of the starter motor. Connect the positive cable of the power supply briefly to connector **1** of the starter motor.
  - If the starter motor does not turn when the circuit is closed:
    - Change the starter motor.

## 24.1 Adjusting the idle speed



(EXC EU/AUS, EXC SIX DAYS, EXC Factory Edition, XC-W)

- Run the engine warm and push the idle speed adjusting screw ① all the way in.
- Set the desired idle speed by turning the idle speed adjusting screw.

Guideline

Idle speed	1,950... 2,050 rpm
------------	--------------------

**Info**

Turn counterclockwise to increase the idle speed.  
Turn clockwise to decrease the idle speed.



(500 EXC US)

- Run the engine warm and push the idle speed adjusting screw ① all the way in.
- Set the desired idle speed by turning the idle speed adjusting screw.

Guideline

Idle speed	1,950... 2,050 rpm
------------	--------------------

**Info**

Turn counterclockwise to increase the idle speed.  
Turn clockwise to decrease the idle speed.

## 24.2 Throttle position sensor circuit A - checking the basic settings

**Condition**

The diagnostics tool is connected and running.

- "Select the measured values" > "Throttle position sensor voltage circuit (THAD)" and "Throttle position sensor signal circuit (ATP)".

Throttle position sensor circuit A	
Basic position - voltage "THAD"	0.601 ± 0.004 V

Throttle position sensor circuit A	
Signal "ATP"	0 %

- If the displayed value does not correspond to specifications:
  - Throttle position sensor - adjust the basic settings. (☛ p. 219)

## 24.3 Throttle position sensor - adjusting the basic settings

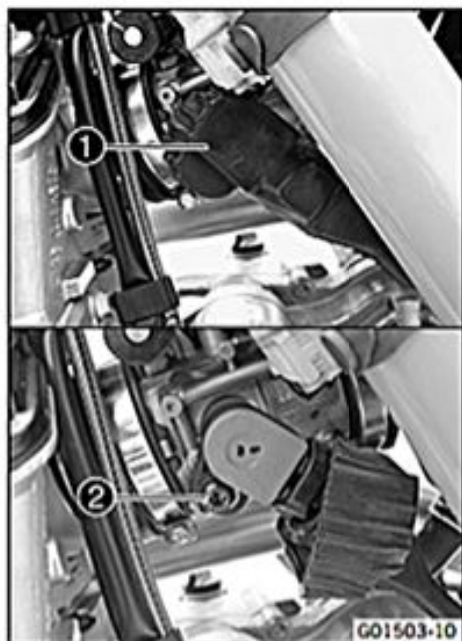

### Condition

The diagnostics tool is connected and running.

- "Select the measured values" > "Throttle position sensor voltage circuit (THAD)" and "Throttle position sensor signal circuit (ATP)".
- Push back protection cap ①.
- Loosen screw ②.
- Set "Throttle position sensor voltage circuit A (THAD)" to the setpoint value. Tighten screw ②.



### Info

The value of "Throttle position sensor signal circuit A (ATP)" must equal the setpoint value.

Throttle position sensor circuit A	
Basic position - voltage "THAD"	0.601...0.004 V

Throttle position sensor circuit A	
Signal "ATP"	0 %

- If the displayed value is equal to the setpoint value:
  - Open and close the throttle grip fully ten times.
  - Check the measured values of "Throttle position sensor voltage circuit A (THAD)" and "Throttle position sensor signal circuit A (ATP)" again.
- Mount protection cap ①.
- "Read trouble code" selected.
- Select "Delete trouble codes".



### Danger

**Danger of poisoning** Exhaust gases are toxic and inhaling them may result in unconsciousness and/or death.

- When running the engine, always make sure there is sufficient ventilation, and do not start or run the engine in an enclosed space without an effective exhaust extraction system.

- Start the engine and perform an initialization run.

### Guideline

Initialization run	5 min
--------------------	-------

## 24.4 Executing the initialization run



### Condition

The diagnostics tool is connected and running.

- Execute "Engine electronics" > "Functions" > "Delete adaptation values".
  - ✓ The adaptation values are deleted.
- Select "Engine electronics" > "Measured values" > "Coolant temperature sensor (TW1)".
  - ✓ The coolant temperature is displayed during the initialization run.



### Danger

**Danger of poisoning** Exhaust gases are toxic and inhaling them may result in unconsciousness and/or death.

- When running the engine, always make sure there is sufficient ventilation, and do not start or run the engine in an enclosed space without an effective exhaust extraction system.

- Start the engine without operating the throttle grip.

### Guideline

Coolant temperature	< 25 °C (< 77 °F)
---------------------	-------------------

- Let the engine idle until it reaches the specified temperature.

### Guideline

Coolant temperature	80... 90 °C (176... 194 °F)
---------------------	-----------------------------

**Info**

Do not operate the throttle grip during the initialization process.

---

- As soon as the specified temperature is reached, switch off the ignition.
- 

**Info**

If the initialization is not completed or the initialization process is interrupted, the entire process must be restarted.

---

## 25.1 Engine

Design	1-cylinder 4-stroke engine, water-cooled
Displacement (all 450 models)	449.3 cm <sup>3</sup> (27.418 cu in)
Displacement (alle 500 Modelle)	510.4 cm <sup>3</sup> (31.147 cu in)
Stroke (all 450 models)	63.4 mm (2.496 in)
Stroke (alle 500 Modelle)	72 mm (2.83 in)
Bore	95 mm (3.74 in)
Compression ratio	11,8:1
Idle speed	1,950... 2,050 rpm
Control	OHC, 4 valves controlled via rocker arm, drive via tooth/wheel chain
Valve diameter, intake	40 mm (1.57 in)
Valve diameter, exhaust	33 mm (1.3 in)
Valve clearance	
Exhaust at: 20 °C (68 °F)	0.12... 0.17 mm (0.0047... 0.0067 in)
Intake at: 20 °C (68 °F)	0.10... 0.15 mm (0.0039... 0.0059 in)
Crankshaft bearing	2 grooved ball bearings
Conrod bearing	Slide bearing
Piston pin bearing	No bearing bushes - DLC-plated piston pins
Pistons	Forged light alloy
Piston rings	1 compression ring, 1 oil scraper ring
Engine lubrication	Pressure circulation lubrication with two rotary pumps
Primary transmission	32:76
Clutch	Multidisc clutch in oil bath / hydraulically activated
Transmission ratio	
1st gear	14:36
2nd gear	17:32
3rd gear	19:28
4th gear	22:26
5th gear	24:23
6th gear	26:21
Alternator	12 V, 200 W
Ignition	Contactless controlled fully electronic ignition with digital ignition adjustment, type Kokusan
Spark plug	NGK LKAR 8AI - 9
Spark plug electrode gap	0.9 mm (0.035 in)
Cooling	Water, permanent circulation of coolant by water pump
Starter	Electric starter/kick starter

## 25.2 Engine tolerance, wear limits

Camshaft - cam height	
Exhaust	33.10... 33.30 mm (1.3031... 1.311 in)
Camshaft - cam height (all 450 models)	
Intake	33.90... 34.10 mm (1.3346... 1.3425 in)
Camshaft - cam height (alle 500 Modelle)	
Intake	34.40... 34.60 mm (1.3543... 1.3622 in)
Valve	
Intake sealing seat width	2.00 mm (0.0787 in)
Exhaust sealing seat width	2.00 mm (0.0787 in)
Run-out at valve plate	≤ 0.05 mm (≤ 0.002 in)
Valve spring	
Intake minimum length (without valve spring seat)	40.7 mm (1.602 in)

Exhaust minimum length (without valve spring seat)	40.7 mm (1.602 in)
Valve spring seat	1.8 mm (0.071 in)
Cylinder/cylinder head - sealing area distortion	≤ 0.10 mm (≤ 0.0039 in)
Piston - diameter	
Size I	94.93... 94.96 mm (3.7374... 3.7386 in)
Size II	94.94... 94.97 mm (3.7378... 3.739 in)
Cylinder - drill hole diameter	
Size I	95.000... 95.012 mm (3.74015... 3.74062 in)
Size II	95.013... 95.025 mm (3.74066... 3.74113 in)
Piston/cylinder - mounting clearance	
Size I	0.040... 0.082 mm (0.00157... 0.00323 in)
Size II	0.043... 0.085 mm (0.00169... 0.00335 in)
Wear limit	0.120 mm (0.00472 in)
Piston ring end gap	
Compression ring	≤ 1.00 mm (≤ 0.0394 in)
Oil scraper ring	≤ 1.20 mm (≤ 0.0472 in)
Conrod bearing - axial clearance	0.20... 0.45 mm (0.0079... 0.0177 in)
Conrod bearing - radial clearance	≤ 0.05 mm (≤ 0.002 in)
Crankshaft - run-out on bearing pin	≤ 0.16 mm (≤ 0.0063 in)
Crankshaft - external crank web dimension	63±0.05 mm (2.48±0.002 in)
Clutch facing disc - thickness	≥ 1.9 mm (≥ 0.075 in)
Clutch spring - length	43.00... 44.03 mm (1.6929... 1.7335 in)
Oil pressure regulator valve	
Minimum length of preload spring	23.5 mm (0.925 in)
Oil pump	
External rotor/engine case clearance	≤ 0.20 mm (≤ 0.0079 in)
External rotor/internal rotor clearance	≤ 0.20 mm (≤ 0.0079 in)
End play	≤ 0.15 mm (≤ 0.0059 in)
Engine oil consumption	≤ 20 ml/h (≤ 0.68 fl. oz./hr)
Shift fork	
Thickness at leaf	4.85... 4.95 mm (0.1909... 0.1949 in)
Shift shaft - play in sliding plate/shift quadrant	0.40... 0.80 mm (0.0157... 0.0315 in)
Transmission shaft - run-out	≤ 0.06 mm (≤ 0.0024 in)

### 25.3 Engine tightening torques

Oil jet, piston cooling	M4	2 Nm (1.5 lbf ft)	Loctite® 243™
Screw, cable holder in alternator cover	M4	4 Nm (3 lbf ft)	Loctite® 243™
Oil jet, piston cooling	M5	2 Nm (1.5 lbf ft)	Loctite® 243™
Oil jet, rocker arm lubrication	M5	2 Nm (1.5 lbf ft)	Loctite® 243™
Screw, bearing retainer	M5	6 Nm (4.4 lbf ft)	Loctite® 2701™
Screw, clutch spring retainer	M5	6 Nm (4.4 lbf ft)	-
Screw, ignition pulse generator	M5	6 Nm (4.4 lbf ft)	Loctite® 243™
Screw, locking lever	M5	6 Nm (4.4 lbf ft)	Loctite® 243™
Screw, oil filter cover	M5	6 Nm (4.4 lbf ft)	-
Screw, oil pump cover	M5	6 Nm (4.4 lbf ft)	Loctite® 243™
Screw, stator	M5	6 Nm (4.4 lbf ft)	Loctite® 243™
Nut, water pump impeller	M6	8 Nm (5.9 lbf ft)	Loctite® 243™
Plug, vacuum connection	M6	2.5 Nm (1.84 lbf ft)	Loctite® 243™
Screw, alternator cover	M6x25	10 Nm (7.4 lbf ft)	-
Screw, camshaft bearing support	M6	10 Nm (7.4 lbf ft)	Loctite® 243™
Screw, clutch cover	M6x25	10 Nm (7.4 lbf ft)	-
Screw, cylinder head	M6	10 Nm (7.4 lbf ft)	-



Screw, engine case	M6x40	10 Nm (7.4 lbf ft)	–
Screw, engine case	M6x60	10 Nm (7.4 lbf ft)	–
Screw, engine case	M6x75	10 Nm (7.4 lbf ft)	–
Screw, engine case	M6x80	10 Nm (7.4 lbf ft)	–
Screw, engine case	M6x85	10 Nm (7.4 lbf ft)	–
Screw, exhaust flange	M6	10 Nm (7.4 lbf ft)	Loctite® 243™
Screw, idler	M6	10 Nm (7.4 lbf ft)	Loctite® 243™
Screw, kick starter spring hanger	M6	10 Nm (7.4 lbf ft)	Loctite® 243™
Screw, kick starter stop	M6	10 Nm (7.4 lbf ft)	Loctite® 243™
Screw, oil pump cover	M6	10 Nm (7.4 lbf ft)	Loctite® 243™
Screw, shift drum locating	M6	10 Nm (7.4 lbf ft)	Loctite® 243™
Screw, shift lever	M6	14 Nm (10.3 lbf ft)	Loctite® 243™
Screw, starter motor	M6	10 Nm (7.4 lbf ft)	–
Screw, timing chain guide rail	M6	10 Nm (7.4 lbf ft)	Loctite® 243™
Screw, timing chain securing guide	M6	10 Nm (7.4 lbf ft)	Loctite® 243™
Screw, timing chain tensioner	M6	10 Nm (7.4 lbf ft)	–
Screw, timing chain tensioning rail	M6	10 Nm (7.4 lbf ft)	Loctite® 243™
Screw, torque governor	M6	10 Nm (7.4 lbf ft)	Loctite® 243™
Screw, valve cover	M6	10 Nm (7.4 lbf ft)	–
Screw, water pump cover	M6x25	10 Nm (7.4 lbf ft)	–
Screw, water pump cover	M6x55	10 Nm (7.4 lbf ft)	–
Oil jet for balancer shaft lubrication	M6x0.75	4 Nm (3 lbf ft)	–
Oil nozzle for conrod bearing lubrication	M6x0.75	4 Nm (3 lbf ft)	–
Plug, oil channel	M7	9 Nm (6.6 lbf ft)	Loctite® 243™
Screw, rocker arm bearing	M7x1	15 Nm (11.1 lbf ft)	–
Plug, crankshaft location	M8	10 Nm (7.4 lbf ft)	–
Screw, clutch cover	M8	10 Nm (7.4 lbf ft)	–
Screw, kick starter	M8	25 Nm (18.4 lbf ft)	Loctite® 2701™
Plug, timing chain tensioner	M8x1	8 Nm (5.9 lbf ft)	–
Plug, oil drilling	M10	15 Nm (11.1 lbf ft)	Loctite® 243™
Screw, engine sprocket	M10	60 Nm (44.3 lbf ft)	Loctite® 2701™
Screw, cylinder head	M10x1.25	Tightening sequence: Tighten diagonally, beginning with the rear screw on the timing chain shaft. Step 1 10 Nm (7.4 lbf ft) Step 2 30 Nm (22.1 lbf ft) Step 3 50 Nm (36.9 lbf ft)	Lubricated with engine oil
Nut, rotor	M12x1	60 Nm (44.3 lbf ft)	–
Spark plug	M12x1.25	15... 20 Nm (11.1... 14.8 lbf ft)	–
Engine coolant temperature sensor	M12x1.5	12 Nm (8.9 lbf ft)	–
Oil drain plug with magnet	M12x1.5	20 Nm (14.8 lbf ft)	–
Oil pressure control valve plug	M12x1.5	20 Nm (14.8 lbf ft)	–
SAS screw plug (500 EXC US)	M12x1.5	20 Nm (14.8 lbf ft)	–
Plug, rocker arm	M14x1.25	20 Nm (14.8 lbf ft)	–
Nut, inner clutch hub	M18x1.5	80 Nm (59 lbf ft)	–
Nut, primary gear	M20LHx1.5	100 Nm (73.8 lbf ft)	Loctite® 648™
Screw plug, engine oil screen	M20x1.5	15 Nm (11.1 lbf ft)	–
Screw plug, gear oil screen	M20x1.5	15 Nm (11.1 lbf ft)	–

**25.4 Capacities****25.4.1 Engine oil**

Engine oil	1.5 l (1.6 qt.)	Engine oil (SAE 10W/50) (☛ p. 310)
------------	-----------------	------------------------------------

**25.4.2 Coolant**

Coolant	1.2 l (1.3 qt.)	Coolant (☛ p. 310)
---------	-----------------	--------------------

**25.4.3 Fuel**

Total fuel tank capacity, approx. (EXC EU/AUS, EXC SIX DAYS, EXC Factory Edition)	9 l (2.4 US gal)	Super unleaded (ROZ 95/RON 95/PON 91) (☛ p. 310)
---	------------------	--

Fuel reserve, approx.	1.5 l (1.6 qt.)
-----------------------	-----------------

**25.5 Chassis**

Frame	Central tube frame made of chrome molybdenum steel tubing	
Fork (EXC EU/AUS/US, XC-W, EXC Factory Edition)	WP Suspension Up Side Down 4860 MXMA PA	
Fork (EXC Six Days)	WP Suspension Up Side Down 4860 4CS	
Suspension travel (EXC EU/AUS/US, XC-W, EXC Factory Edition)		
Front	300 mm (11.81 in)	
Suspension travel (EXC Six Days)		
Front	300 mm (11.81 in)	
Suspension travel		
Rear	335 mm (13.19 in)	
Fork offset	20 mm (0.79 in)	
Shock absorber	WP Performance Systems 5018 PDS DCC	
Brake system	Disc brakes, brake calipers on floating bearings	
Brake discs - diameter		
Front	260 mm (10.24 in)	
Rear	220 mm (8.66 in)	
Brake discs - wear limit		
Front	2.5 mm (0.098 in)	
Rear	3.5 mm (0.138 in)	
Tire air pressure off road		
Front	1.0 bar (15 psi)	
Rear	1.0 bar (15 psi)	
Road tire pressure (All EXC models)		
Front	1.5 bar (22 psi)	
Rear	1.5 bar (22 psi)	
Final drive (all 450 EXC models)	14:52 (13:52)	
Final drive (500 EXC EU, 500 EXC Six Days EU, 500 EXC AU)	14:50 (13:50)	
Final drive (450 XC-W US)	13:52	
Final drive (500 XC-W US)	13:50	
Final drive (500 EXC US)	14:50 (13:50)	
Chain	5/8 x 1/4"	
Rear sprockets available (EXC EU/AUS, EXC SIX DAYS, EXC Factory Edition, XC-W)	38, 40, 42, 45, 48, 49, 50, 51, 52	
Rear sprockets available (500 EXC US)	40, 42, 45, 48, 49, 50, 51, 52, 54	
Steering head angle	63.5°	
Wheelbase	1,482±10 mm (58.35±0.39 in)	
Seat height unloaded	970 mm (38.19 in)	
Ground clearance unloaded	345 mm (13.58 in)	

Homologated weight without fuel, approx. (EXC EU/AUS, EXC SIX DAYS, EXC Factory Edition)	112.0 kg (246.9 lb.)
Homologated weight without fuel, approx. (500 EXC US)	113.5 kg (250.2 lb.)
Weight without fuel, approx. (450 XC-W US)	111.0 kg (244.7 lb.)
Weight without fuel, approx. (500 XC-W US)	111.5 kg (245.8 lb.)
Maximum permissible front axle load	145 kg (320 lb.)
Maximum permissible rear axle load	190 kg (419 lb.)
Maximum permissible overall weight	335 kg (739 lb.)

## 25.6 Electrical system

Battery	YTX5L-BS	Battery voltage: 12 V Nominal capacity: 4 Ah Maintenance-free
Speedometer battery	CR 2430	Battery voltage: 3 V
Fuse	58011109105	5 A
Fuse	75011088010	10 A
Fuse	58011109120	20 A
Headlight	HS1 / socket PX43t	12 V 35/35 W
Parking light	W5W / socket W2.1x9.5d	12 V 5 W
Indicator lamps	W2.3W / socket W2x4.6d	12 V 2.3 W
Turn signal (EXC EU/AUS, EXC SIX DAYS, EXC Factory Edition)	R10W / socket BA15s	12 V 10 W
Turn signal (500 EXC US)	RY10W / socket BAU15s	12 V 10 W
Brake/tail light	LED	
License plate lamp (All EXC models)	W5W / socket W2.1x9.5d	12 V 5 W

## 25.7 Tires

Validity	Front tires	Rear tires
(EXC EU, EXC AU, 500 EXC US)	80/100 - 21 M/C 51M TT MAXXIS Maxx EnduPro	140/80 - 18 M/C 70R TT MAXXIS Maxx EnduPro
(XC-W)	90/90 - 21 54M TT Dunlop GEOMAX AT81F	110/100 - 18 64M TT Dunlop GEOMAX AT81
(EXC Factory Edition, EXC Six Days, 500 EXC US)	90/90 - 21 M/C 54M M+S TT Metzeler MCE 6 Days Extreme	140/80 - 18 M/C 70M M+S TT Metzeler MCE 6 Days Extreme

Additional information is available in the Service section under:  
<http://www.ktm.com>

## 25.8 Fork

### 25.8.1 EXC EU/AUS/US, XC-W, EXC Factory Edition

Fork part number	14.18.7L.69
Fork	WP Suspension Up Side Down 4860 MXMA PA
Compression damping	
Comfort	22 clicks
Standard	20 clicks
Sport	18 clicks
Rebound damping	
Comfort	20 clicks
Standard	18 clicks
Sport	16 clicks

<b>Spring preload - Preload Adjuster</b>		
Comfort		1 turn
Standard		2 turns
Sport		2 turns
<b>Spring length with preload spacer(s)</b>		
Weight of rider: 65... 75 kg (143... 165 lb.)		513 mm (20.2 in)
Weight of rider: 75... 85 kg (165... 187 lb.)		513 mm (20.2 in)
Weight of rider: 85... 95 kg (187... 209 lb.)		513 mm (20.2 in)
<b>Spring rate</b>		
Weight of rider: 65... 75 kg (143... 165 lb.)		4.2 N/mm (24 lb/in)
Weight of rider: 75... 85 kg (165... 187 lb.)		4.4 N/mm (25.1 lb/in)
Weight of rider: 85... 95 kg (187... 209 lb.)		4.6 N/mm (26.3 lb/in)
Fork length		940 mm (37.01 in)
Air chamber length		110:38 mm (4.33:38 in)
Fork oil per fork leg	618 ml (20.89 fl. oz.)	Fork oil (SAE 4) (48601166S1) (☛ p. 310)

**25.8.2 EXC Six Days**

Fork part number		24.18.7N.69
Fork		WP Suspension Up Side Down 4860 4CS
<b>Compression damping</b>		
Comfort		15 clicks
Standard		13 clicks
Sport		11 clicks
<b>Rebound damping</b>		
Comfort		15 clicks
Standard		13 clicks
Sport		11 clicks
Spring length with preload spacer(s)		472 mm (18.58 in)
<b>Spring rate</b>		
Weight of rider: 65... 75 kg (143... 165 lb.)		4.2 N/mm (24 lb/in)
Weight of rider: 75... 85 kg (165... 187 lb.)		4.4 N/mm (25.1 lb/in)
Weight of rider: 85... 95 kg (187... 209 lb.)		4.6 N/mm (26.3 lb/in)
Fork length		932 mm (36.69 in)
Air chamber length		100 mm (3.94 in)
Oil capacity per fork leg	635 ml (21.47 fl. oz.)	Fork oil (SAE 4) (48601166S1) (☛ p. 310)

**25.9 Shock absorber**

Shock absorber part number		12.18.7L.69
Shock absorber		WP Performance Systems 5018 PDS DCC
<b>Compression damping, low-speed</b>		
Comfort		25 clicks
Standard		20 clicks
Sport		15 clicks
<b>Compression damping, high-speed</b>		
Comfort		2 turns
Standard		1.5 turns
Sport		1.25 turns
<b>Rebound damping</b>		
Comfort		28 clicks
Standard		24 clicks
Sport		22 clicks

Spring preload	
Comfort	9 mm (0.35 in)
Standard	9 mm (0.35 in)
Sport	9 mm (0.35 in)
Spring rate	
Weight of rider: 65... 75 kg (143... 165 lb.)	69 N/mm (394 lb/in)
Weight of rider: 75... 85 kg (165... 187 lb.)	72 N/mm (411 lb/in)
Weight of rider: 85... 95 kg (187... 209 lb.)	76 N/mm (434 lb/in)
Spring length	250 mm (9.84 in)
Gas pressure	10 bar (145 psi)
Static sag	33... 35 mm (1.3... 1.38 in)
Riding sag	105... 115 mm (4.13... 4.53 in)
Fitted length	417 mm (16.42 in)
Damper oil	Shock absorber fluid (SAE 2.5) (50180751S1) (☛ p. 310)

### 25.10 Chassis tightening torques

Screw, pressure regulator	EJOT PT® K60x25-Z	3 Nm (2.2 lbf ft)	–
Spoke nipple, front wheel	M4.5	6 Nm (4.4 lbf ft)	–
Spoke nipple, rear wheel	M4.5	6 Nm (4.4 lbf ft)	–
Screw, battery terminal	M5	2.5 Nm (1.84 lbf ft)	–
Screw, intake air temperature sensor	M5	2 Nm (1.5 lbf ft)	–
Screw, shock absorber adjusting ring	M5	5 Nm (3.7 lbf ft)	–
Screw, spoiler on fuel tank (XC-W)	M5x12	1.5 Nm (1.11 lbf ft)	–
Nut, cable on starter motor	M6	4 Nm (3 lbf ft)	–
Remaining nuts, chassis	M6	10 Nm (7.4 lbf ft)	–
Remaining screws, chassis	M6	10 Nm (7.4 lbf ft)	–
Screw, ball joint of push rod on foot brake cylinder	M6	10 Nm (7.4 lbf ft)	Loctite® 243™
Screw, chain sliding guard	M6	6 Nm (4.4 lbf ft)	Loctite® 243™
Screw, front brake disc	M6	14 Nm (10.3 lbf ft)	Loctite® 243™
Screw, rear brake disc	M6	14 Nm (10.3 lbf ft)	Loctite® 243™
Screw, throttle grip	M6	5 Nm (3.7 lbf ft)	–
Fuel connection on fuel pump	M8	10 Nm (7.4 lbf ft)	–
Nut, foot brake lever stop	M8	20 Nm (14.8 lbf ft)	–
Nut, rear sprocket screw	M8	35 Nm (25.8 lbf ft)	Loctite® 2701™
Nut, rim lock	M8	12 Nm (8.9 lbf ft)	–
Remaining nuts, chassis	M8	25 Nm (18.4 lbf ft)	–
Remaining screws, chassis	M8	25 Nm (18.4 lbf ft)	–
Screw, bottom triple clamp (EXC Factory Edition, EXC Six Days)	M8	15 Nm (11.1 lbf ft)	–
Screw, bottom triple clamp (EXC EU/AUS/US, XC-W)	M8	15 Nm (11.1 lbf ft)	–
Screw, chain sliding piece	M8	15 Nm (11.1 lbf ft)	–
Screw, engine brace	M8	33 Nm (24.3 lbf ft)	Loctite® 2701™
Screw, fork stub	M8	15 Nm (11.1 lbf ft)	–
Screw, front brake caliper	M8	25 Nm (18.4 lbf ft)	Loctite® 243™
Screw, handlebar clamp	M8	20 Nm (14.8 lbf ft)	–
Screw, side stand attachment	M8	45 Nm (33.2 lbf ft)	Loctite® 2701™
Screw, subframe	M8	35 Nm (25.8 lbf ft)	Loctite® 2701™
Screw, top steering stem (EXC Factory Edition, EXC Six Days)	M8	17 Nm (12.5 lbf ft)	Loctite® 243™
Screw, top steering stem (EXC EU/AUS/US, XC-W)	M8	20 Nm (14.8 lbf ft)	–

Screw, top triple clamp (EXC Factory Edition, EXC Six Days)	M8	17 Nm (12.5 lbf ft)	-
Screw, top triple clamp (EXC EU/AUS/US, XC-W)	M8	20 Nm (14.8 lbf ft)	-
Engine attachment bolt	M10	60 Nm (44.3 lbf ft)	-
Remaining nuts, chassis	M10	45 Nm (33.2 lbf ft)	-
Remaining screws, chassis	M10	45 Nm (33.2 lbf ft)	-
Screw, handlebar holder	M10	40 Nm (29.5 lbf ft)	Loctite® 243™
Nut, fuel pump fixation	M12	15 Nm (11.1 lbf ft)	-
Screw, bottom shock absorber	M12	80 Nm (59 lbf ft)	Loctite® 2701™
Screw, top shock absorber	M12	80 Nm (59 lbf ft)	Loctite® 2701™
Nut, seat fixing	M12x1	20 Nm (14.8 lbf ft)	-
Nut, swingarm pivot	M16x1.5	100 Nm (73.8 lbf ft)	-
Nut, rear wheel spindle	M20x1.5	80 Nm (59 lbf ft)	-
Screw, top steering head	M20x1.5	12 Nm (8.9 lbf ft)	-
Screw-in nozzles, cooling system	M20x1.5	12 Nm (8.9 lbf ft)	Loctite® 243™
Screw, front wheel spindle	M24x1.5	45 Nm (33.2 lbf ft)	-

## 26.1 Cleaning the motorcycle

**Note**

**Material damage** Damage and destruction of components by high-pressure cleaning equipment.

- When cleaning the vehicle with a pressure cleaner, do not point the water jet directly onto electrical components, connectors, cables, bearings, etc. Maintain a minimum distance of 60 cm between the nozzle of the pressure cleaner and the component. Excessive pressure can cause malfunctions or destroy these parts.

**Warning**

**Environmental hazard** Hazardous substances cause environmental damage.

- Oil, grease, filters, fuel, cleaners, brake fluid, etc., should be disposed of as stipulated in applicable regulations.

**Info**

If you clean the motorcycle regularly, its value and appearance will be maintained over a long period. Avoid direct sunshine on the motorcycle during cleaning.

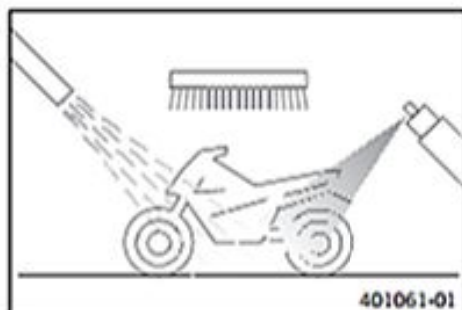

- Close off the exhaust system to keep water from entering.
- First remove coarse dirt particles with a gentle spray of water.
- Spray very dirty areas with a normal motorcycle cleaner and then clean with a paintbrush.

Motorcycle cleaner (☛ p. 311)

**Info**

Use warm water containing normal motorcycle cleaner and a soft sponge. Never apply motorcycle cleaner to the dry vehicle; always rinse with water first.

- After rinsing the motorcycle with a gentle spray of water, allow it to dry thoroughly.
- Remove the plug from the exhaust system.

**Warning**

**Danger of accidents** Reduced braking efficiency due to a wet or dirty brake system.

- Clean or dry a dirty or wet brake system by riding and braking gently.

- After cleaning, ride a short distance until the engine reaches operating temperature.

**Info**

The heat produced causes water at inaccessible locations in the engine and brake system to evaporate.

- After the motorcycle has cooled off, lubricate all moving parts and bearings.
- Clean the chain. (☛ p. 115)
- Treat bare metal parts (except for brake discs and exhaust system) with anti-corrosion materials.

Preserving materials for paints, metal and rubber (☛ p. 312)

- Treat all plastic parts and powder-coated parts with a mild cleaning and care product.

Special cleaner for glossy and matte paint finishes, metal and plastic surfaces (☛ p. 312)

**(All EXC models)**

- Grease steering lock.

Universal oil spray (☛ p. 312)

**(500 EXC US)**

- Lubricate the ignition switch.

Universal oil spray (☛ p. 312)

## 26.2 Checks and maintenance steps for winter operation

**i** Info

If you use the vehicle in winter, you must expect salt on the roads. You should therefore take precautions against aggressive road salt.

If the vehicle was operated in road salt, clean it with cold water after riding. Warm water would enhance the corrosive effects of salt.

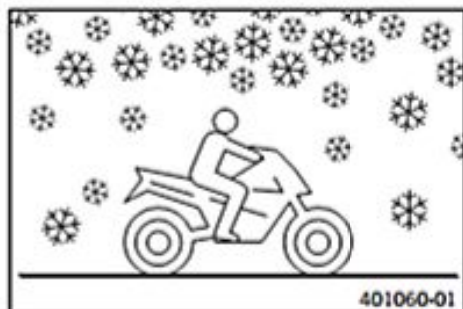

- Clean the motorcycle. (☞ p. 229)
- Clean the brake system.

**i** Info

After **EVERY** trip on salted roads, thoroughly wash the brake calipers and brake linings, in the cooled down and installed state, with cold water and dry carefully.

After riding on salted roads, thoroughly wash the vehicle with cold water and dry it well.

- Treat the engine, swingarm, and all other bright and zinc-plated parts (except for the brake discs) with a wax-based corrosion inhibitor.

**i** Info

Corrosion inhibitor is not permitted to come in contact with the brake discs as this would greatly reduce the braking force.

- Clean the chain. (☞ p. 115)



## 27.1 Storage

**Warning**

**Danger of poisoning** Fuel is poisonous and a health hazard.

- Fuel must not come into contact with the skin, eyes, or clothing. Do not breathe in the fuel vapors. If contact occurs with the eyes, rinse with water immediately and contact a physician. Immediately clean contaminated areas on the skin with soap and water. If fuel is swallowed, contact a physician immediately. Change clothing that has been contaminated with fuel. Store fuel properly in a suitable canister and keep away from children.

**Info**

If you want to garage the motorcycle for a longer period, take the following steps.

Before storing the motorcycle, check all parts for function and wear. If service, repairs or replacements are necessary, you should do this during the storage period (less workshop overload). In this way, you can avoid long workshop waiting times at the start of the new season.

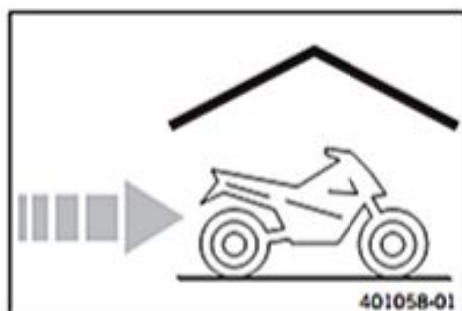

- When refueling for the last time before taking the motorcycle out of service, add fuel additive.

Fuel additive (☛ p. 311)

- Refuel.
- Clean the motorcycle. (☛ p. 229)
- Change the engine oil and oil filter and clean the oil screens. (☛ p. 211)
- Check the antifreeze and coolant level. (☛ p. 207)
- Check the tire air pressure. (☛ p. 106)
- Remove the battery. (☛ p. 117)
- Charge the battery.

**Guideline**

Storage temperature of battery without direct sunlight	0... 35 °C (32... 95 °F)
--	--------------------------

- Store the vehicle in a dry location that is not subject to large fluctuations in temperature.

**Info**

KTM recommends raising the motorcycle.

- Raise the motorcycle with the lift stand. (☛ p. 11)
- Preferably cover the vehicle with a tarp or similar cover that is permeable to air. Do not use non-porous materials since they prevent humidity from escaping, thus causing corrosion.

**Info**

Avoid running the engine for a short time only. Since the engine cannot warm up properly, the water vapor produced during combustion condenses and causes valves and exhaust system to rust.

## 27.2 Preparing for use after storage

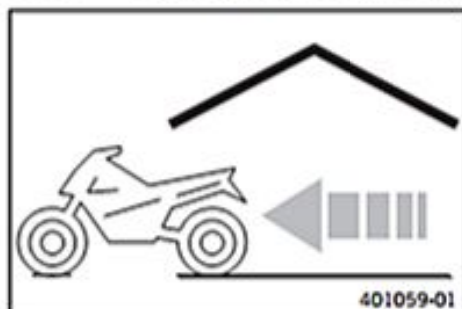

- Remove the motorcycle from the lift stand. (☛ p. 11)
- Install the battery. (☛ p. 118)
- Perform checks and maintenance work when preparing the vehicle for use.
- Take a test ride.

## 28.1 Service schedule

	Every 30 operating hours/after every race	Every 15 operating hours	Once after 1 operating hour
Read out the fault memory using the KTM diagnostics tool.	○	●	●
Check that the electrical equipment is functioning properly.	○	●	●
Check and charge the battery.		●	●
Check the front brake linings. (☛ p. 120)		●	●
Check the rear brake linings. (☛ p. 125)		●	●
Check the brake discs. (☛ p. 107)		●	●
Check the brake lines for damage and leakage.		●	●
Check the rear brake fluid level. (☛ p. 128)		●	●
Check the free travel of the foot brake lever. (☛ p. 127)		●	●
Check the frame and swingarm.		●	●
Check the swingarm bearing.			●
Check the heim joints at the top and bottom of the shock absorber.		●	●
Check the tire condition. (☛ p. 106)	○	●	●
Check the tire air pressure. (☛ p. 106)	○	●	●
Check the wheel bearing for play.		●	●
Check the wheel hubs.		●	●
Check the rim run-out.	○	●	●
Check the spoke tension. (☛ p. 107)	○	●	●
Check the chain, rear sprocket, engine sprocket and chain guide. (☛ p. 113)		●	●
Check the chain tension. (☛ p. 112)	○	●	●
Grease all moving parts (e.g., side stand, hand lever, chain, ...) and check for smooth operation.		●	●
Check/correct the fluid level of the hydraulic clutch. (☛ p. 205)		●	●
Check the brake fluid level of the front brake. (☛ p. 123)		●	●
Check the free travel of the hand brake lever. (☛ p. 122)		●	●
Check the steering head bearing play. (☛ p. 57)	○	●	●
Check the valve clearance.	○		●
Check the clutch.			●
Change the engine oil and oil filter and clean the oil screens. (☛ p. 211)	○	●	●
Check all hoses (e. g., fuel, cooling, bleeding, drainage) and sleeves for cracking, leaks, and incorrect routing.	○	●	●
Check the antifreeze and coolant level. (☛ p. 207)	○	●	●
Check the cables for damage and routing without sharp bends.		●	●
Check that the cables are undamaged, routed without sharp bends and set correctly.	○	●	●
Clean the air filter and air filter box.		●	●
Change glass fiber yarn filling in the main silencer. (☛ p. 88)			●
Check the screws and nuts for tightness.	○	●	●
Check the headlight setting. (☛ p. 131)	○	●	●
Change the fuel screen. (☛ p. 97)	○	●	●
Check the fuel pressure. (☛ p. 101)		●	●
Adjust the idle speed. (☛ p. 218)	○	●	●
Check that the radiator fan is functioning properly.	○	●	●
Final check: Check the vehicle for roadworthiness and take a test ride.	○	●	●
Read out the fault memory using the KTM diagnostics tool after a test ride.	○	●	●
Make the service entry in the KTM Dealer.net and in the Service and Warranty Booklet.	○	●	●

○ One-time interval

● Periodic interval

## 28.2 Service work (as additional order)

	Every 135 operating hours/every 70 operating hours when used for motorsports	Every 45 operating hours	Once after 15 operating hours	Annually
Change the front brake fluid. (☛ p. 124)				•
Change the rear brake fluid. (☛ p. 129)				•
Change the hydraulic clutch fluid. (☛ p. 205)				•
Grease the steering head bearing. (☛ p. 55)				•
Clean the spark arrestor. (XC-W, 500 EXC US)				•
Perform a fork service. (EXC Six Days) (☛ p. 40)	○	•	•	
Perform a fork service. (EXC EU/AUS/US, XC-W, EXC Factory Edition) (☛ p. 21)	○	•	•	
Service the shock absorber. (☛ p. 68)		•	•	
Change the spark plug and spark plug connector.				•
Change the piston.				•
Check/measure the cylinder.				•
Check the cylinder head.				•
Change the valves, valve springs and valve spring seats.				•
Check the camshaft and cam lever.				•
Change the connecting rod, conrod bearing, and crank pin.				•
Check the transmission and shift mechanism.				•
Check the oil pressure regulator valve.				•
Check the oil pumps and lubrication system.				•
Check the timing assembly.				•
Change all engine bearings.				•

- One-time interval
- Periodic interval

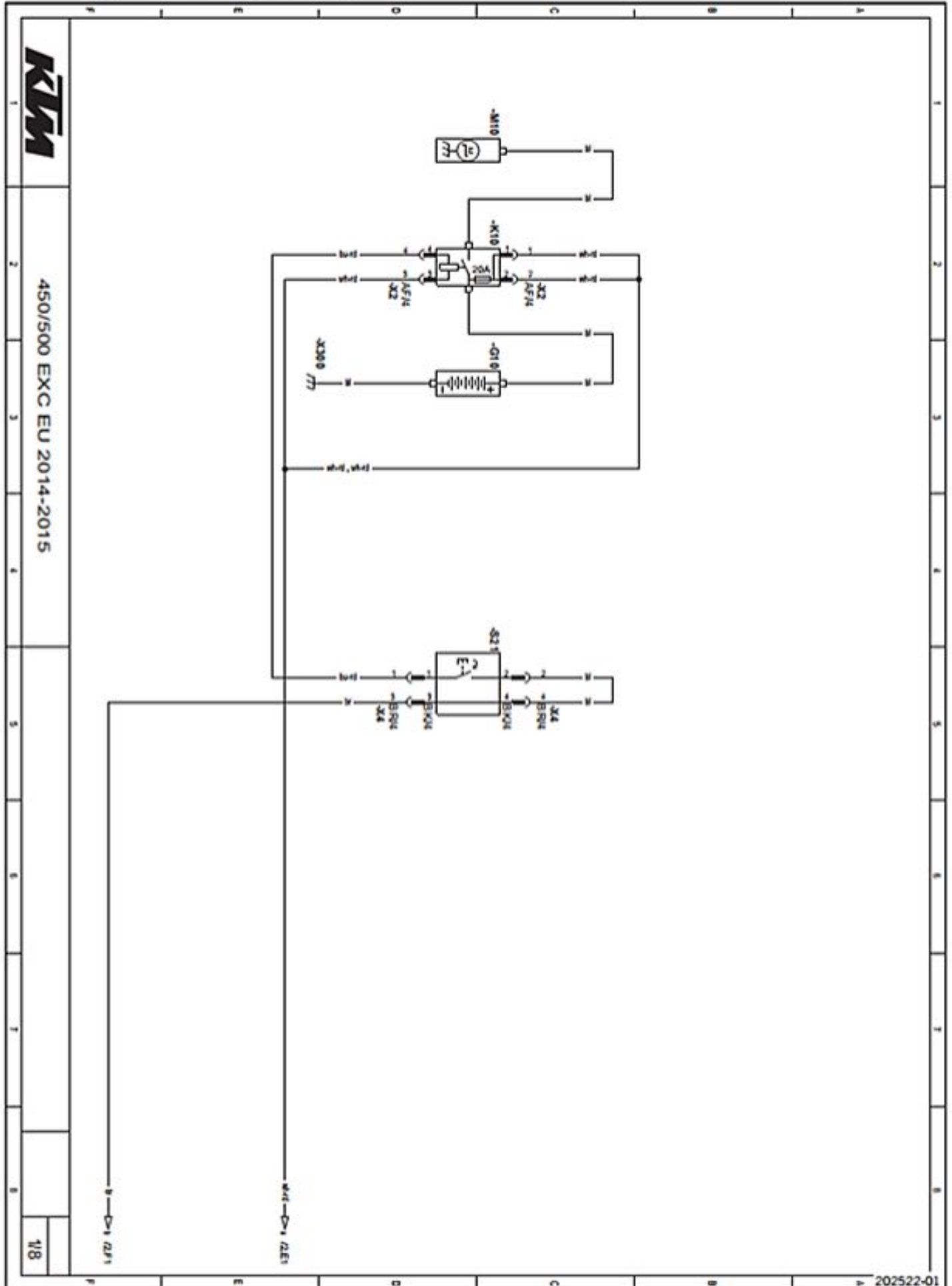

**Components:**

G10	Battery
K10	Starter relay with main fuse
M10	Starter motor
S21	Electric starter button

29.2 Page 2 of 8 (EXC EU, EXC Factory Edition)

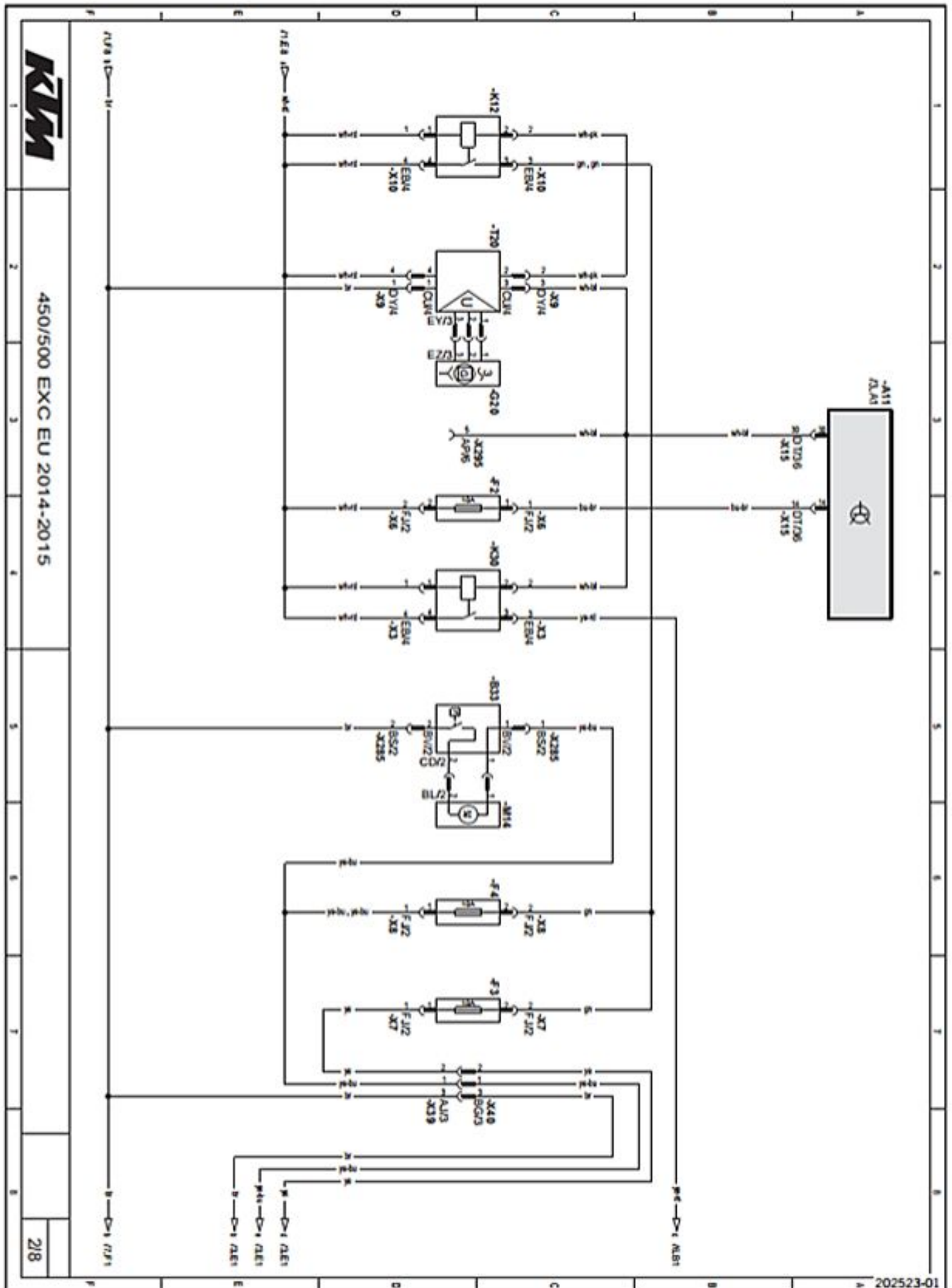

**Components:**

A11	EFI control unit
B33	Radiator fan temperature switch
F2	Fuse
F3	Fuse
F4	Fuse
G20	Alternator
K12	Light relay
K30	Power relay
M14	Radiator fan
T20	Voltage regulator
X295	Diagnostics connector

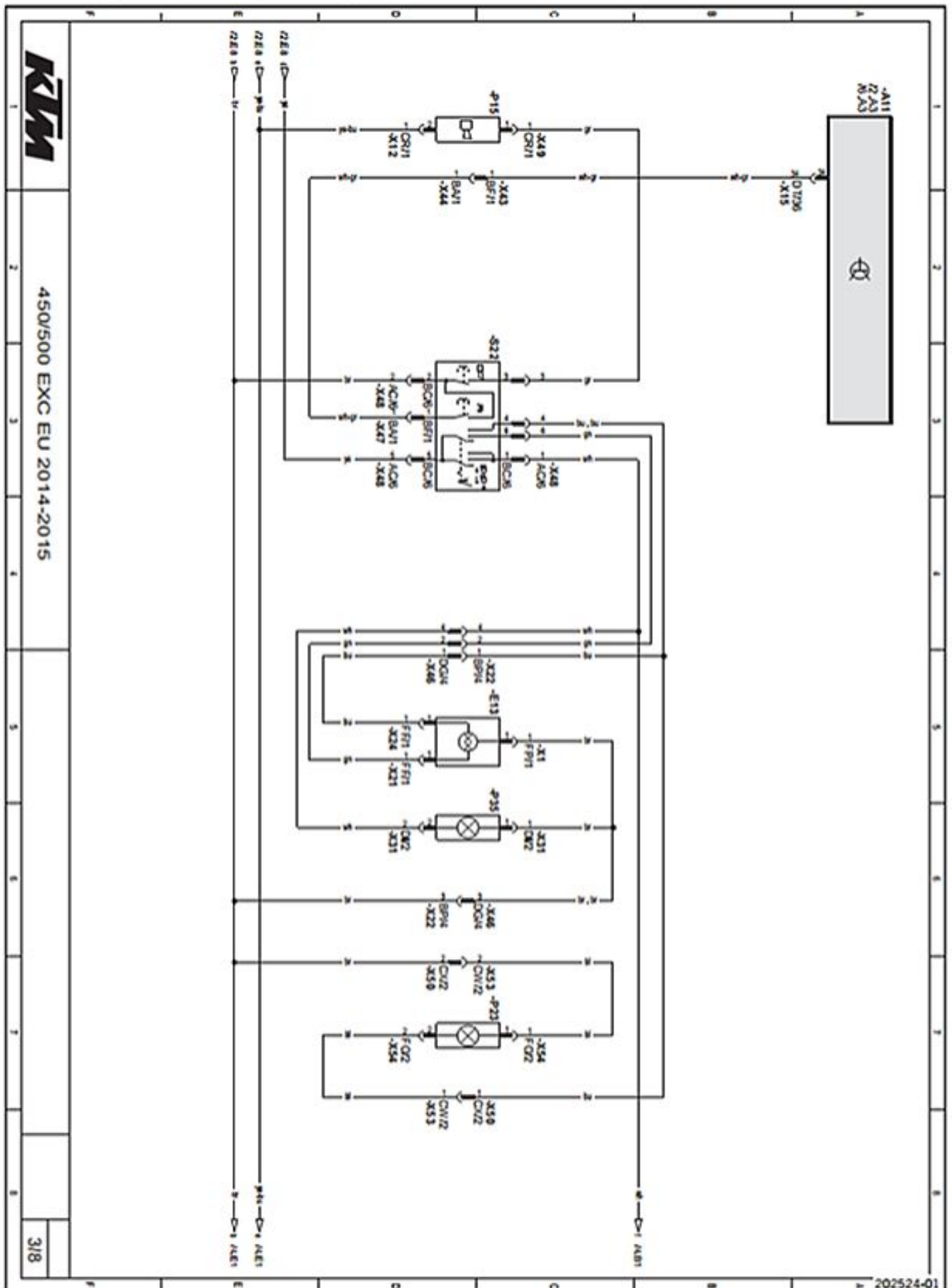



**Components:**

A11	EFI control unit
E13	Low beam, high beam
P15	Horn
P23	High beam indicator lamp
P35	Parking light
S22	Light switch, horn button, kill switch

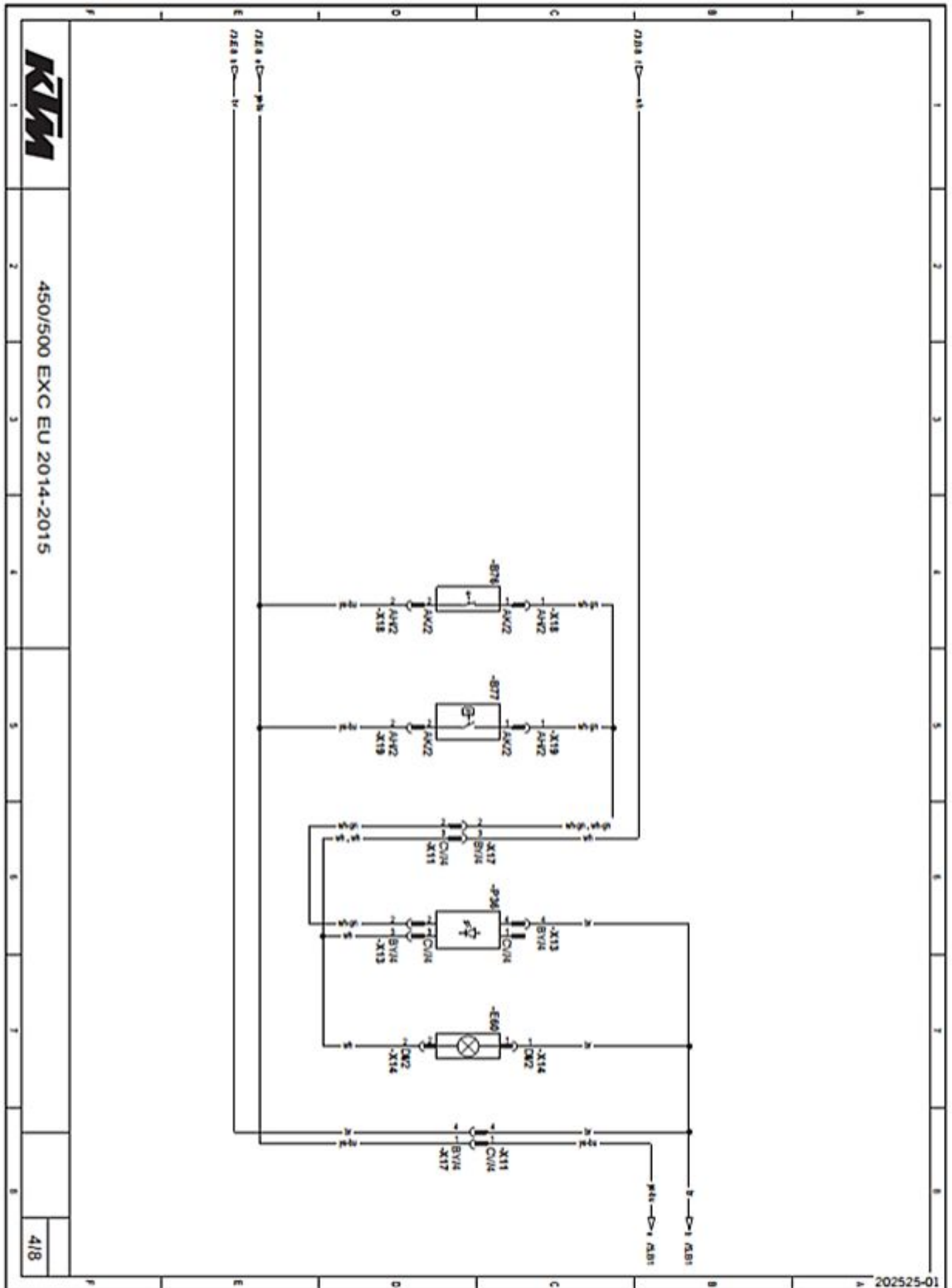

**Components:**

---

B76	Brake light switch, front
-----	---------------------------

---

B77	Brake light switch, rear
-----	--------------------------

---

E60	License plate lamp
-----	--------------------

---

P36	Brake/tail light
-----	------------------

---

29.5 Page 5 of 8 (EXC EU, EXC Factory Edition)

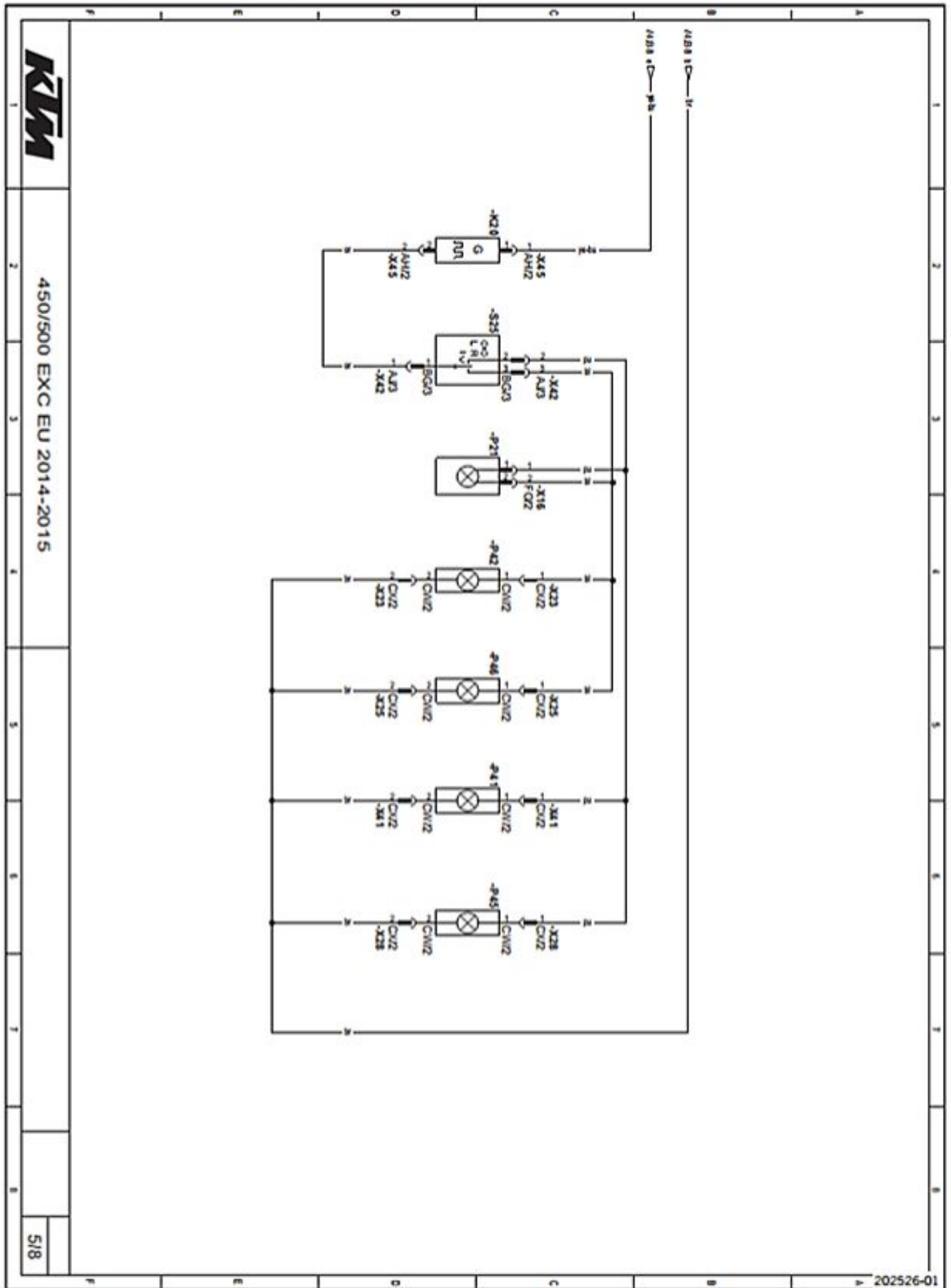

450/500 EXC EU 2014-2015

**Components:**

K20	Turn signal relay
P21	Turn signal indicator light
P41	Turn signal, front left
P42	Turn signal, front right
P45	Turn signal, rear left
P46	Turn signal, rear right
S25	Turn signal switch

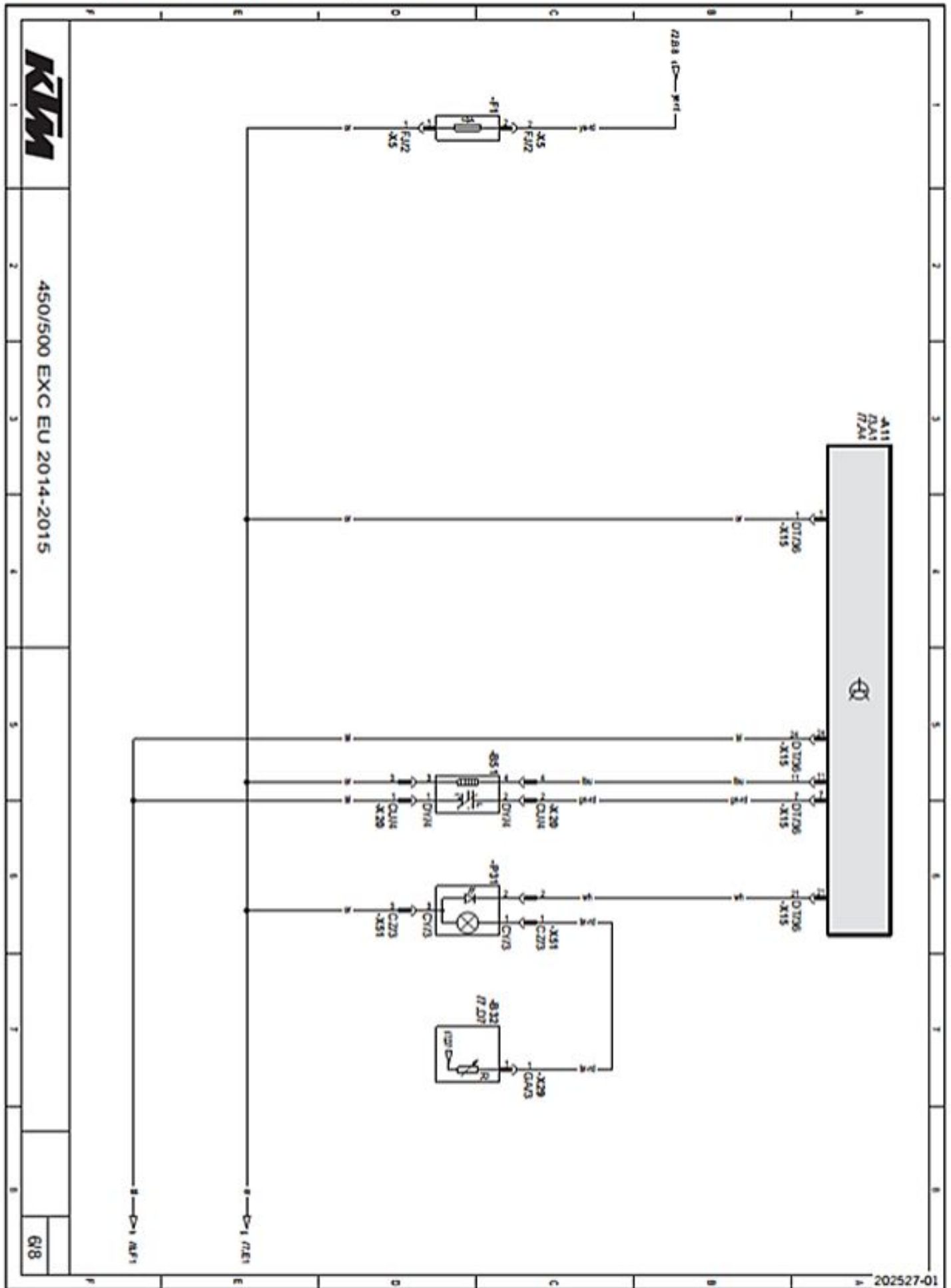

**KTM**

450/500 EXC EU 2014-2015

6/8

**Components:**

A11	EFI control unit
B32	Fuel level sensor
B51	Lambda sensor (cylinder 1)
F1	Fuse
P31	FI warning lamp and low fuel warning lamp

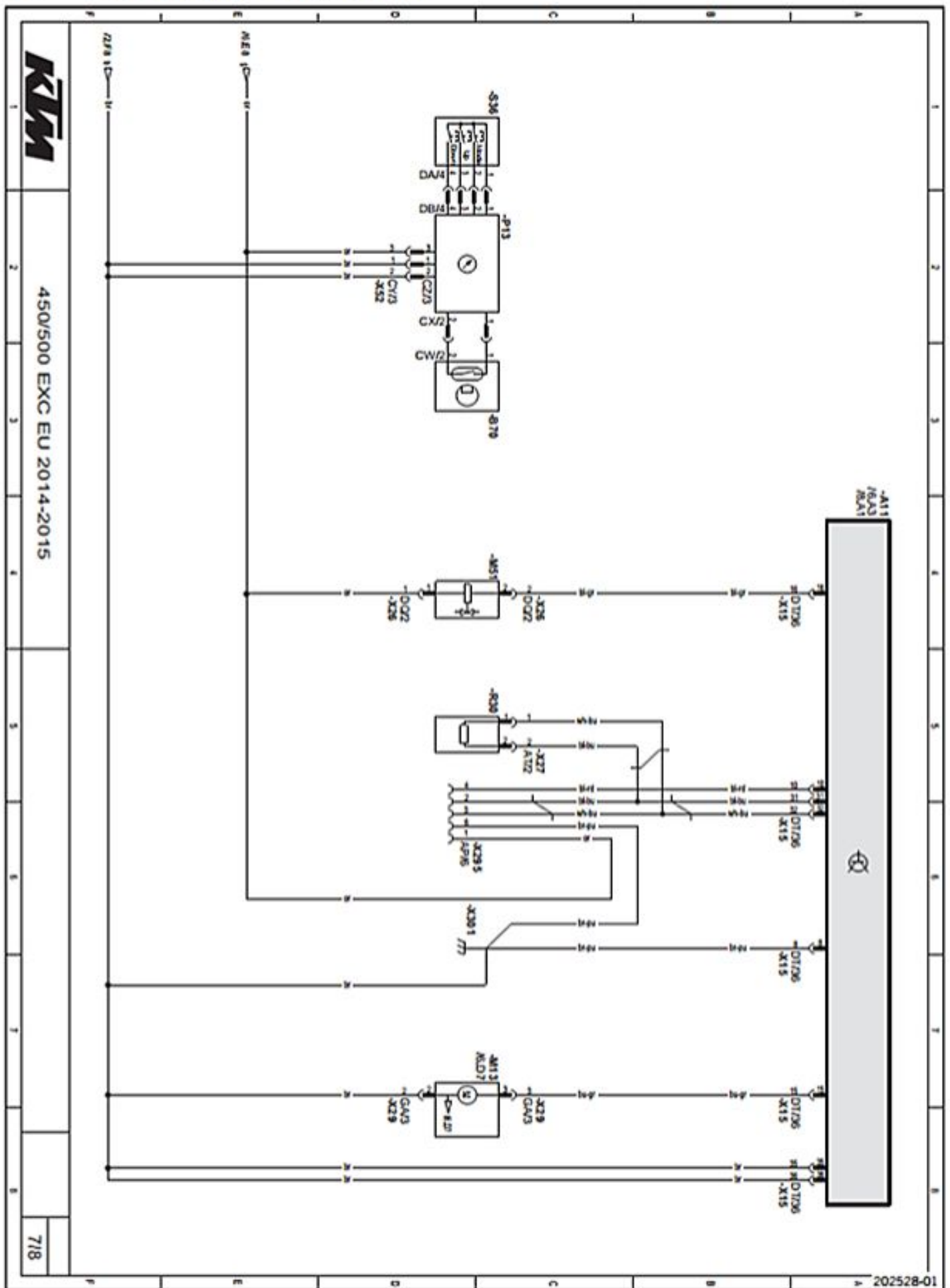



**Components:**

A11	EFI control unit
B70	Front wheel speed sensor
M13	Fuel pump
M51	Injector (cylinder 1)
R30	CAN-bus terminating resistor 1
P13	Speedometer
S36	Tripmaster switch
X295	Diagnostics connector

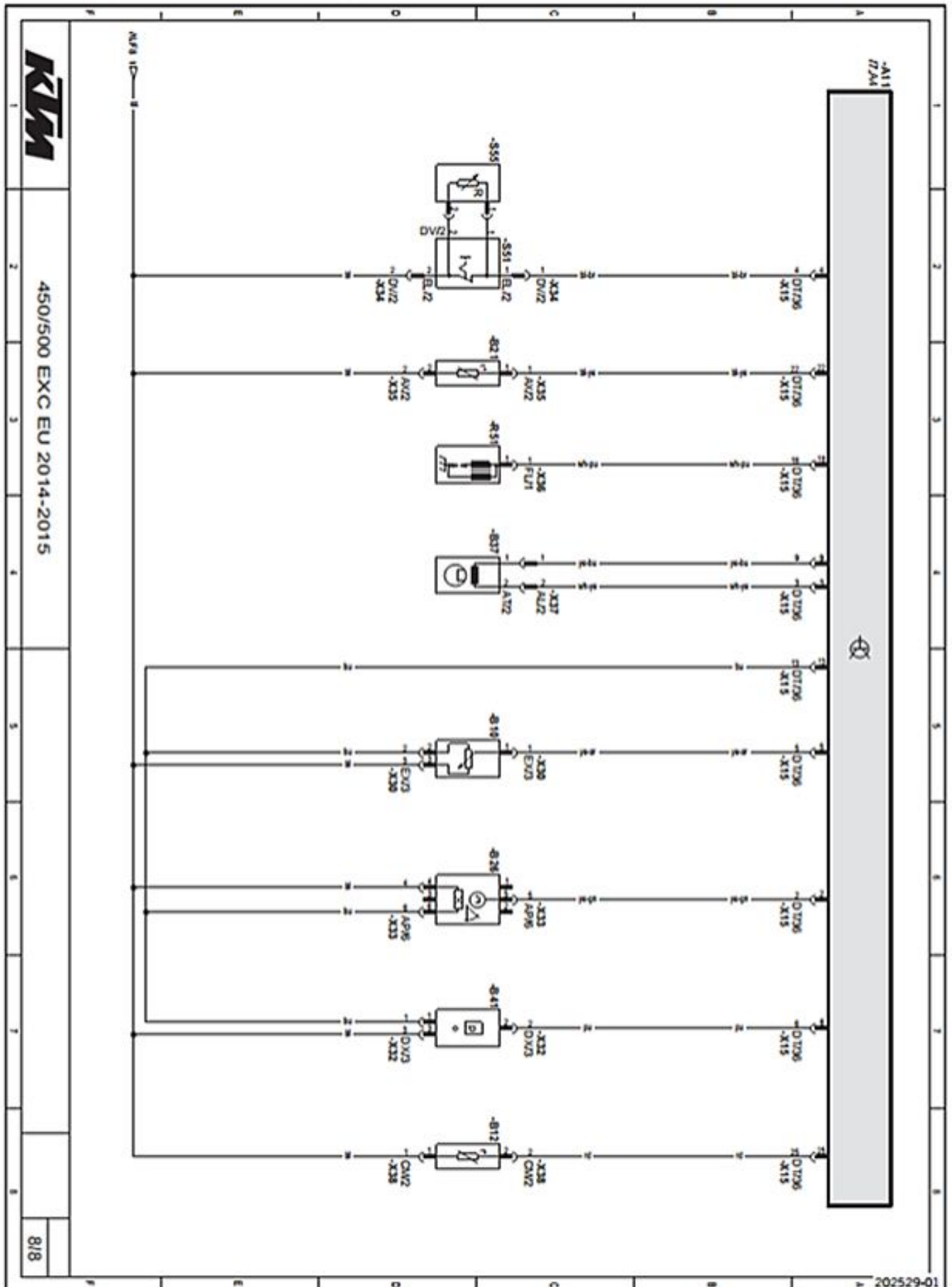

**Components:**

A11	EFI control unit
B10	Throttle position sensor circuit A
B12	Intake air temperature sensor
B21	Coolant temperature sensor (cylinder 1)
B26	Rollover sensor
B37	Crankshaft position sensor
B41	Manifold absolute pressure sensor (cylinder 1)
R51	Ignition coil (cylinder 1)
S51	<b>Map-Select</b> switch for ride mode (optional)
S55	<b>Map-Select</b> switch for basic position (optional)

**Cable colors:**

bl	Black
br	Brown
bu	Blue
gn	Green
gr	Gray
lbu	Light blue
or	Orange
pk	Pink
pu	Violet
rd	Red
wh	White
ye	Yellow

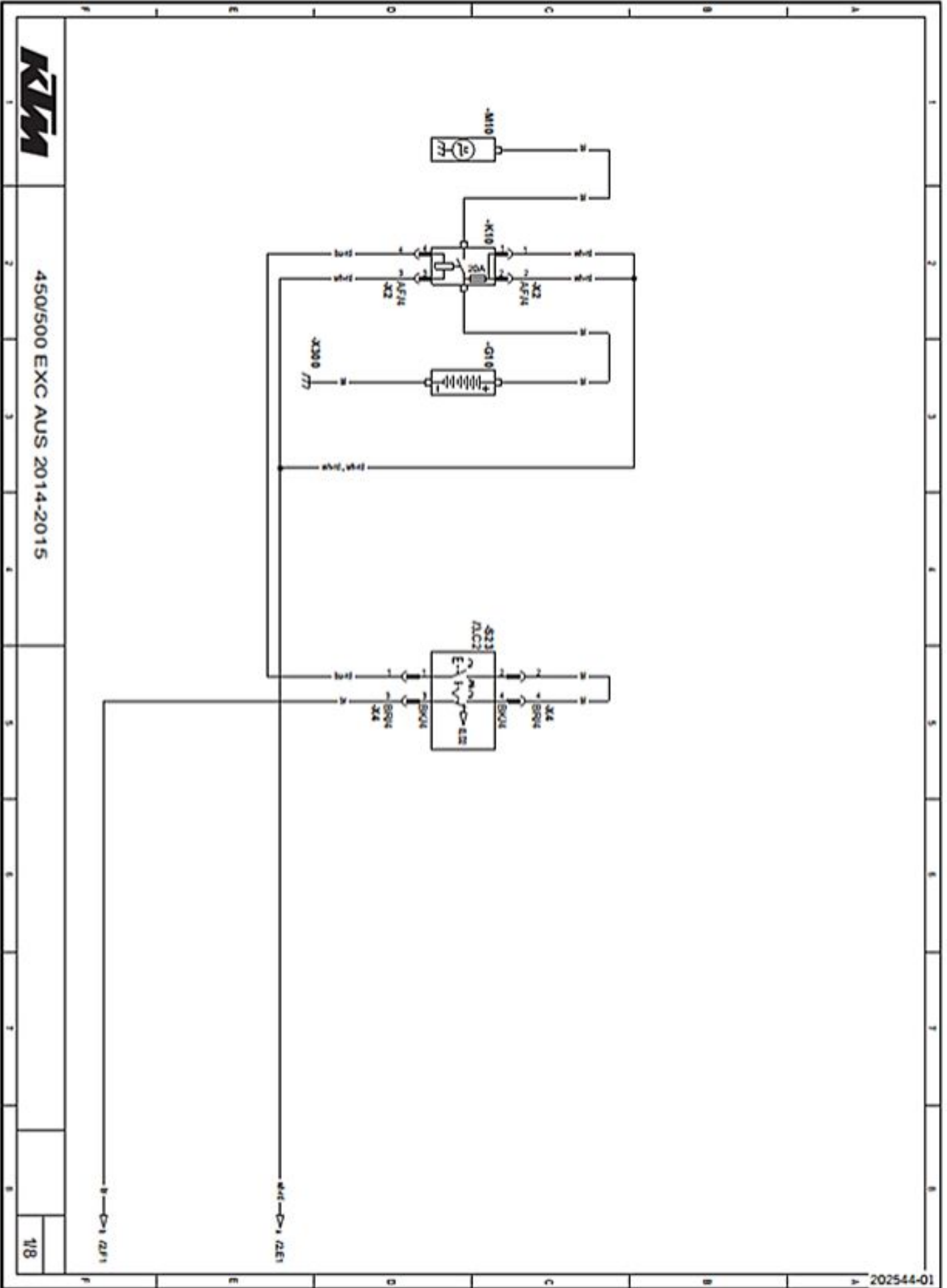

**Components:**

G10	Battery
K10	Starter relay with main fuse
M10	Starter motor
S23	Emergency OFF switch, electric starter button

29.10 Page 2 of 8 (EXC AU)

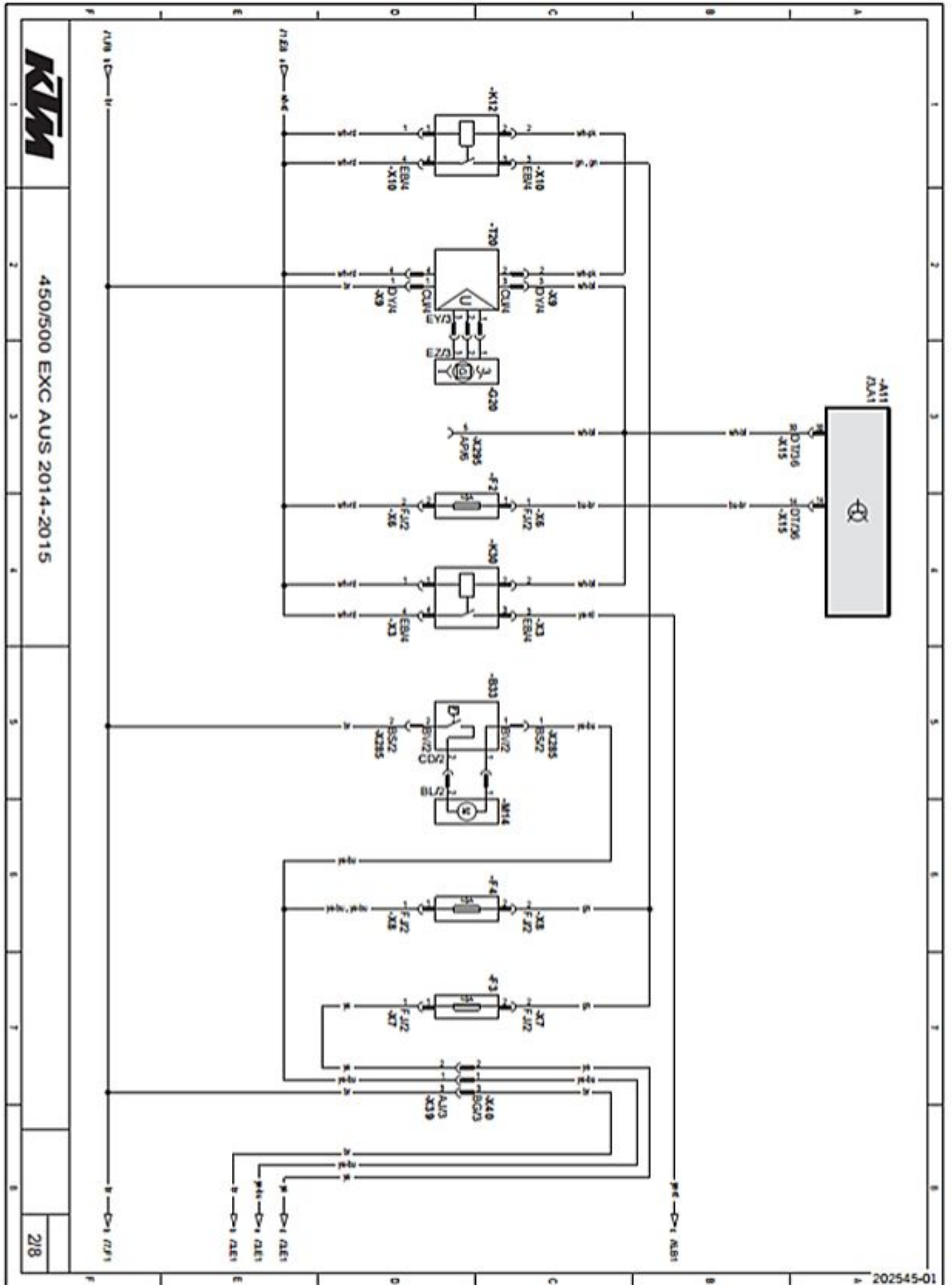

**Components:**

A11	EFI control unit
B33	Radiator fan temperature switch
F2	Fuse
F3	Fuse
F4	Fuse
G20	Alternator
K12	Light relay
K30	Power relay
M14	Radiator fan
T20	Voltage regulator
X295	Diagnostics connector





**Components:**

A11	EFI control unit
E13	Low beam, high beam
P15	Horn
P23	High beam indicator lamp
P35	Parking light
S22	Light switch, horn button, kill switch
S23	Emergency OFF switch, electric starter button

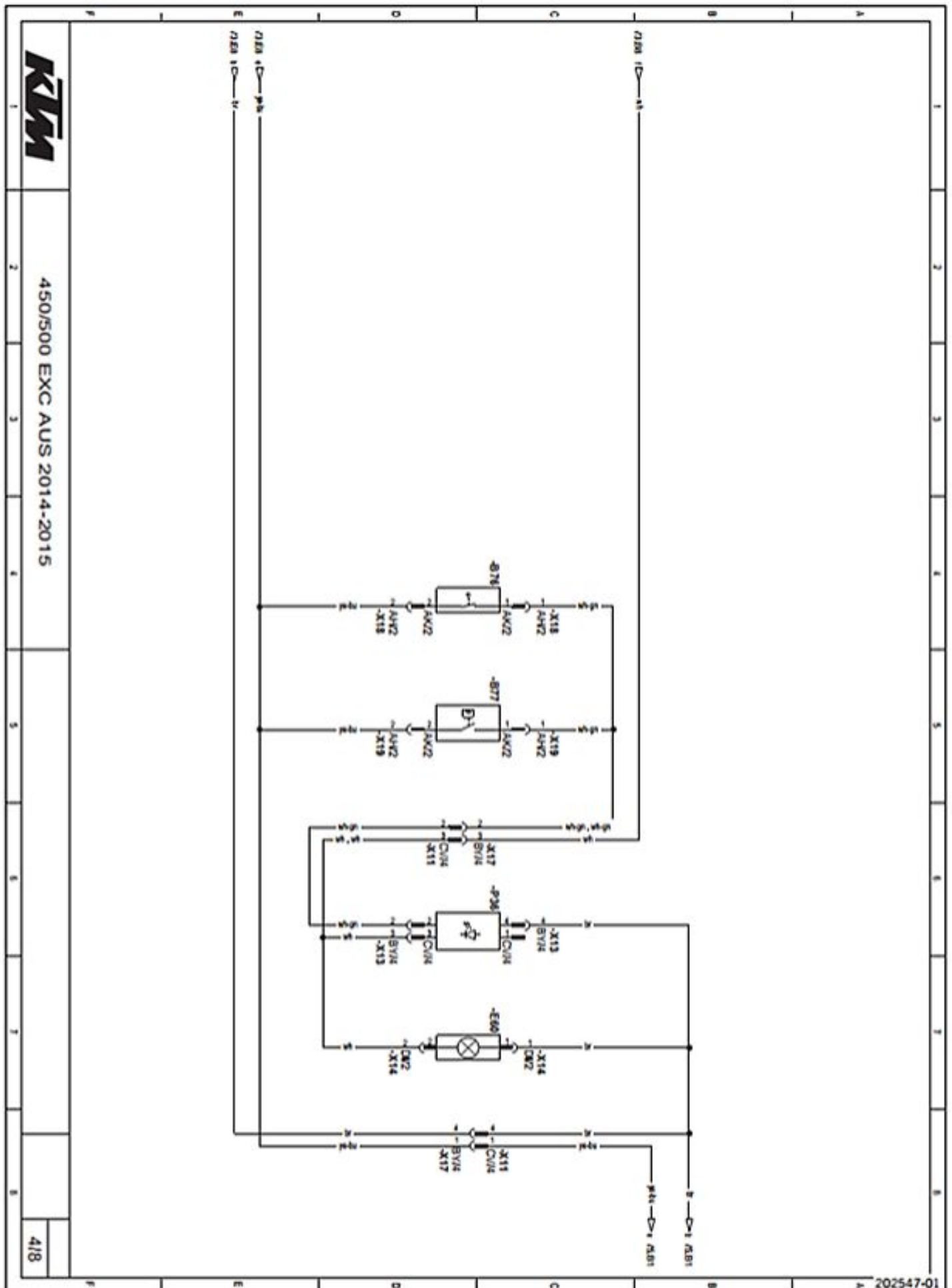

450/500 EXC AUS 2014-2015

**Components:**

---

B76	Brake light switch, front
-----	---------------------------

---

B77	Brake light switch, rear
-----	--------------------------

---

E60	License plate lamp
-----	--------------------

---

P36	Brake/tail light
-----	------------------

---

29.13 Page 5 of 8 (EXC AU)

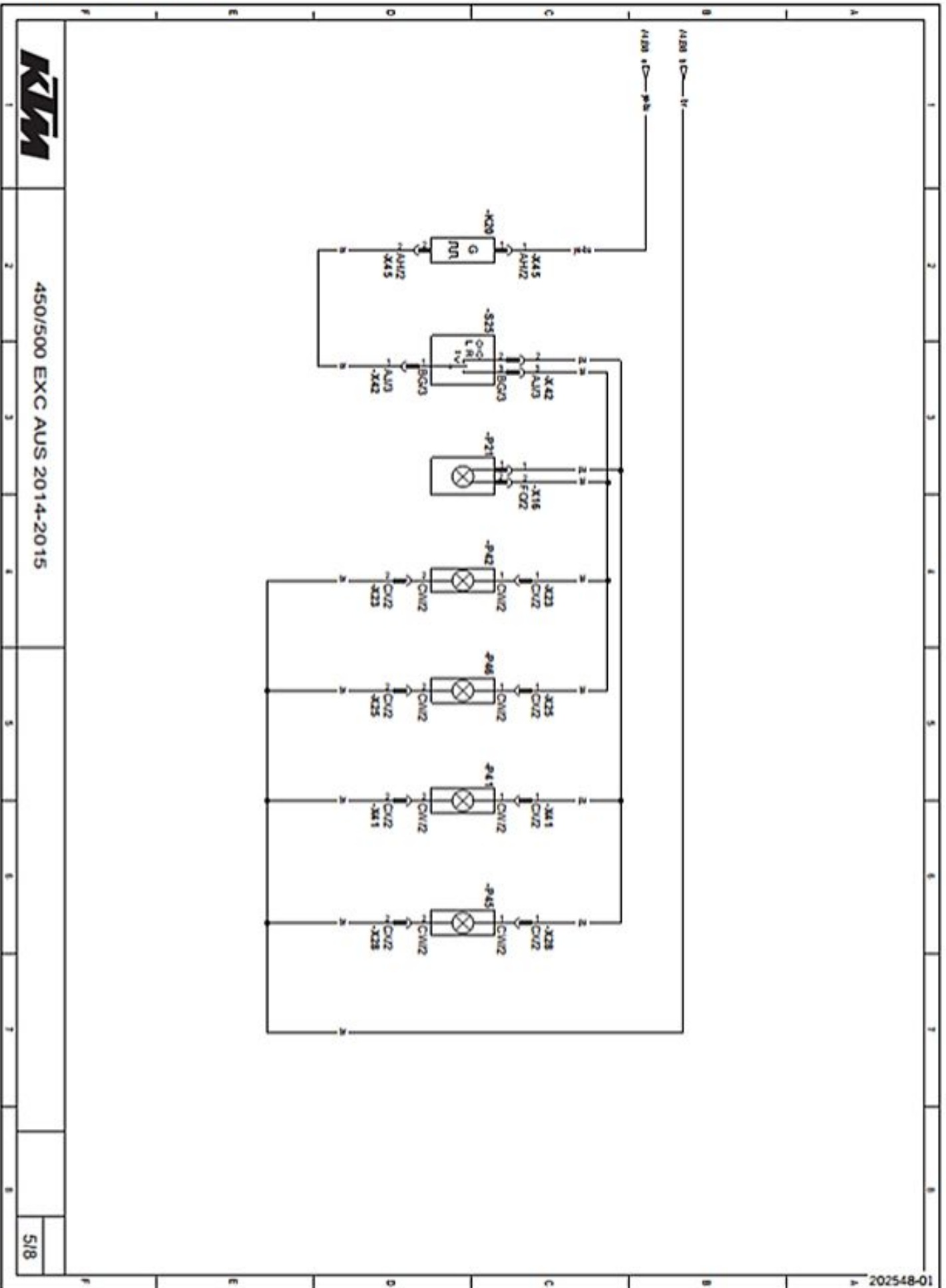

450/500 EXC AUS 2014-2015

**Components:**

K20	Turn signal relay
P21	Turn signal indicator light
P41	Turn signal, front left
P42	Turn signal, front right
P45	Turn signal, rear left
P46	Turn signal, rear right
S25	Turn signal switch

29.14 Page 6 of 8 (EXC AU)

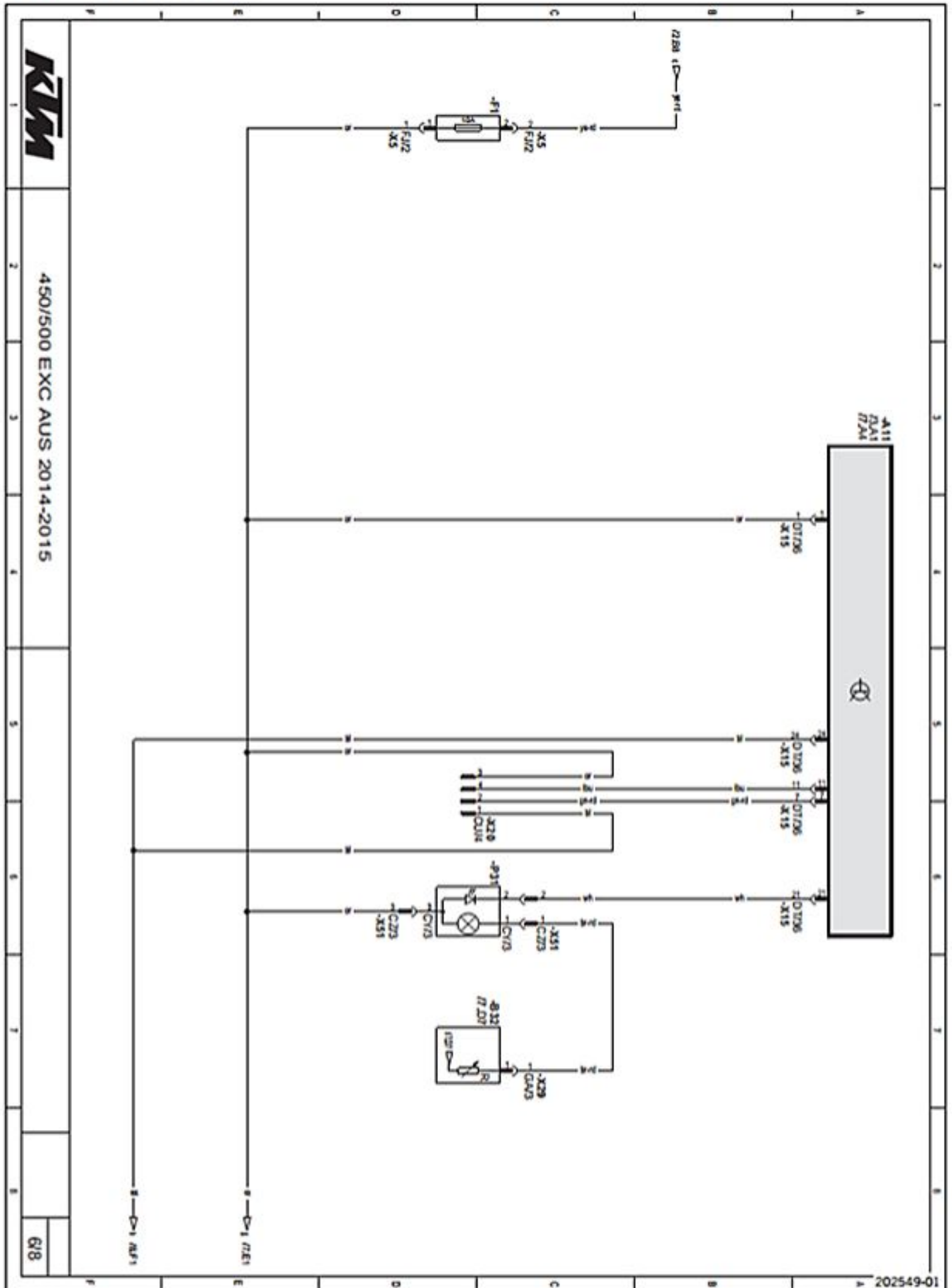

450/500 EXC AUS 2014-2015

**Components:**

---

A11	EFI control unit
B32	Fuel level sensor
F1	Fuse
P31	FI warning lamp and low fuel warning lamp

---

29.15 Page 7 of 8 (EXC AU)

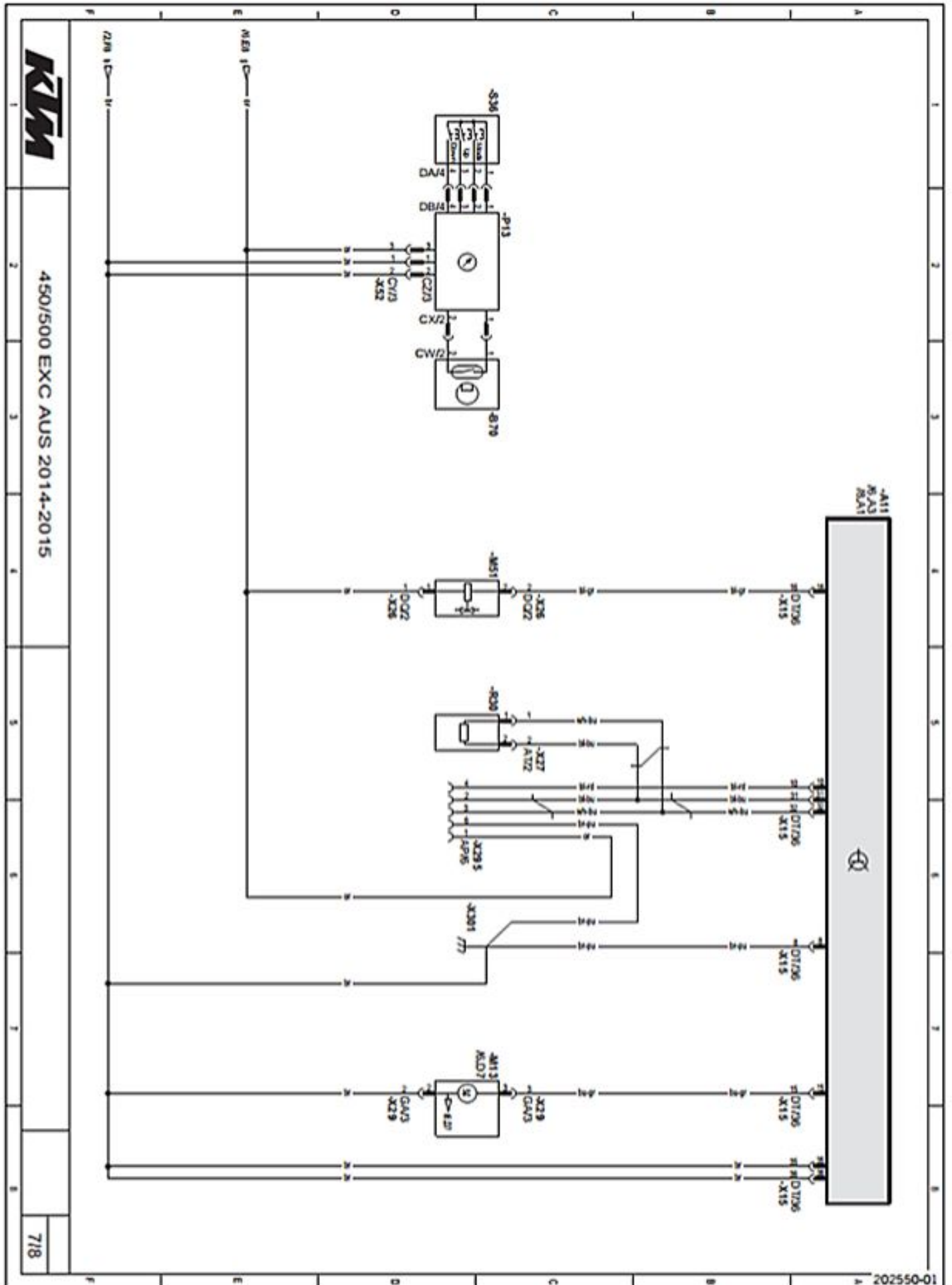



**Components:**

A11	EFI control unit
B70	Front wheel speed sensor
M13	Fuel pump
M51	Injector (cylinder 1)
R30	CAN-bus terminating resistor 1
P13	Speedometer
S36	Tripmaster switch
X295	Diagnostics connector

29.16 Page 8 of 8 (EXC AU)

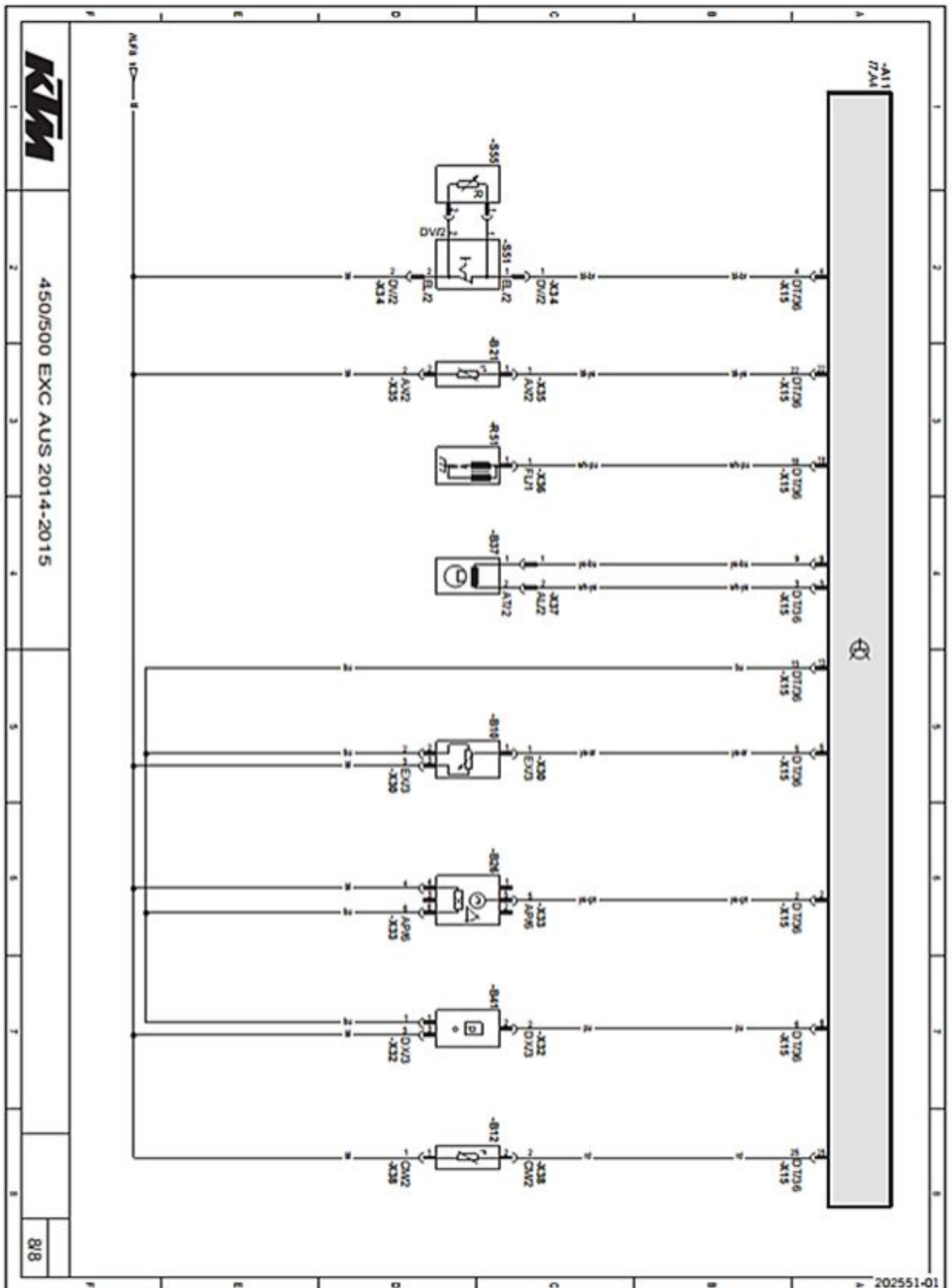

450/500 EXC AUS 2014-2015

**Components:**

A11	EFI control unit
B10	Throttle position sensor circuit A
B12	Intake air temperature sensor
B21	Engine coolant temperature sensor (cylinder 1)
B26	Rollover sensor
B37	Ignition pulse generator
B41	Manifold absolute pressure sensor (cylinder 1)
R51	Ignition coil (cylinder 1)
S51	<b>Map-Select</b> switch for riding mode (optional)
S55	<b>Map-Select</b> switch for basic setting (optional)

**Cable colors:**

bl	Black
br	Brown
bu	Blue
gn	Green
gr	Gray
lbu	Light blue
or	Orange
pk	Pink
pu	Violet
rd	Red
wh	White
ye	Yellow

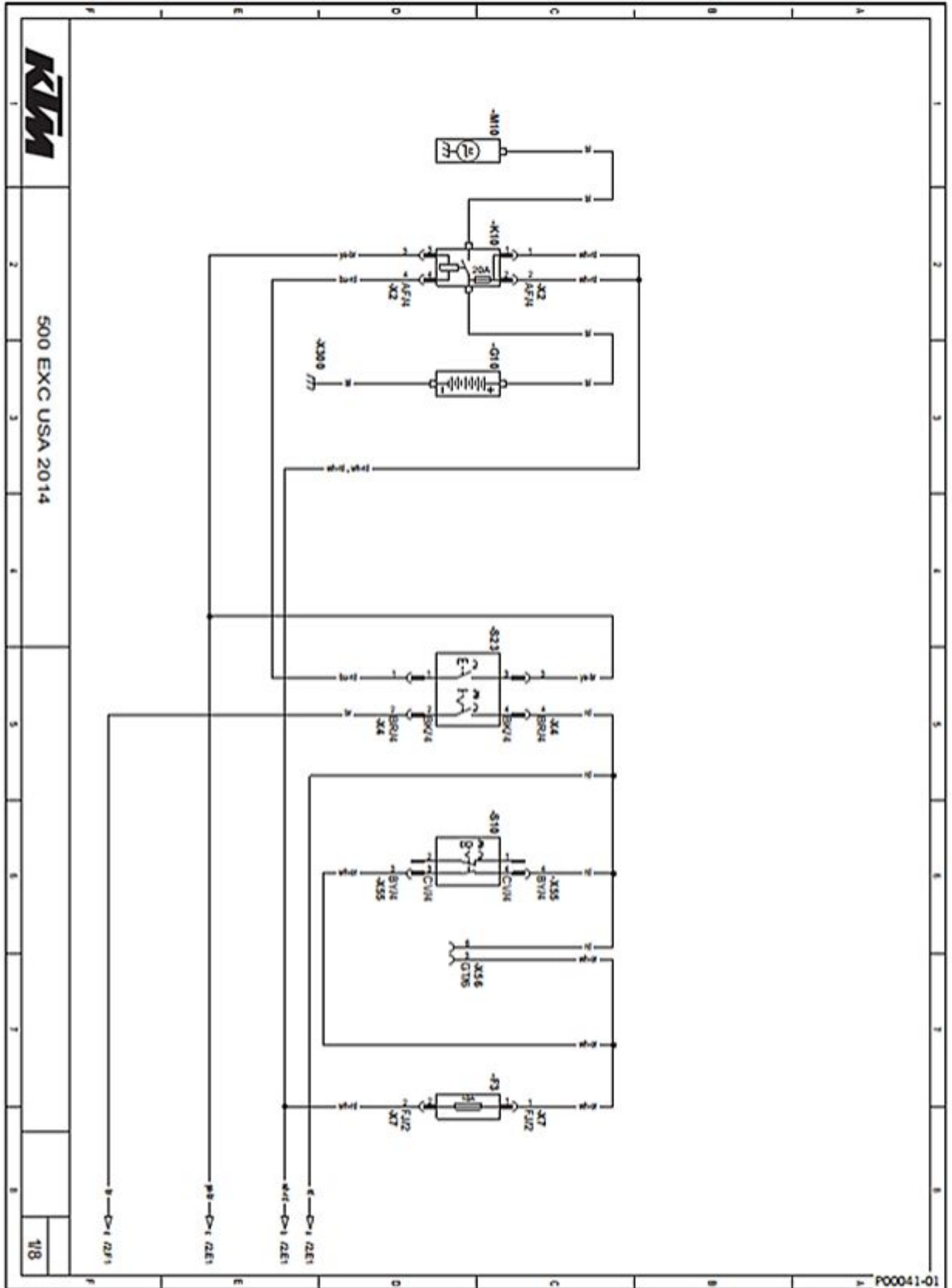

**Components:**

F3	Fuse
G10	Battery
K10	Starter relay with main fuse
M10	Starter motor
S10	Ignition lock
S23	Emergency OFF switch, electric starter button

29.18 Page 2 of 8 (500 EXC US)

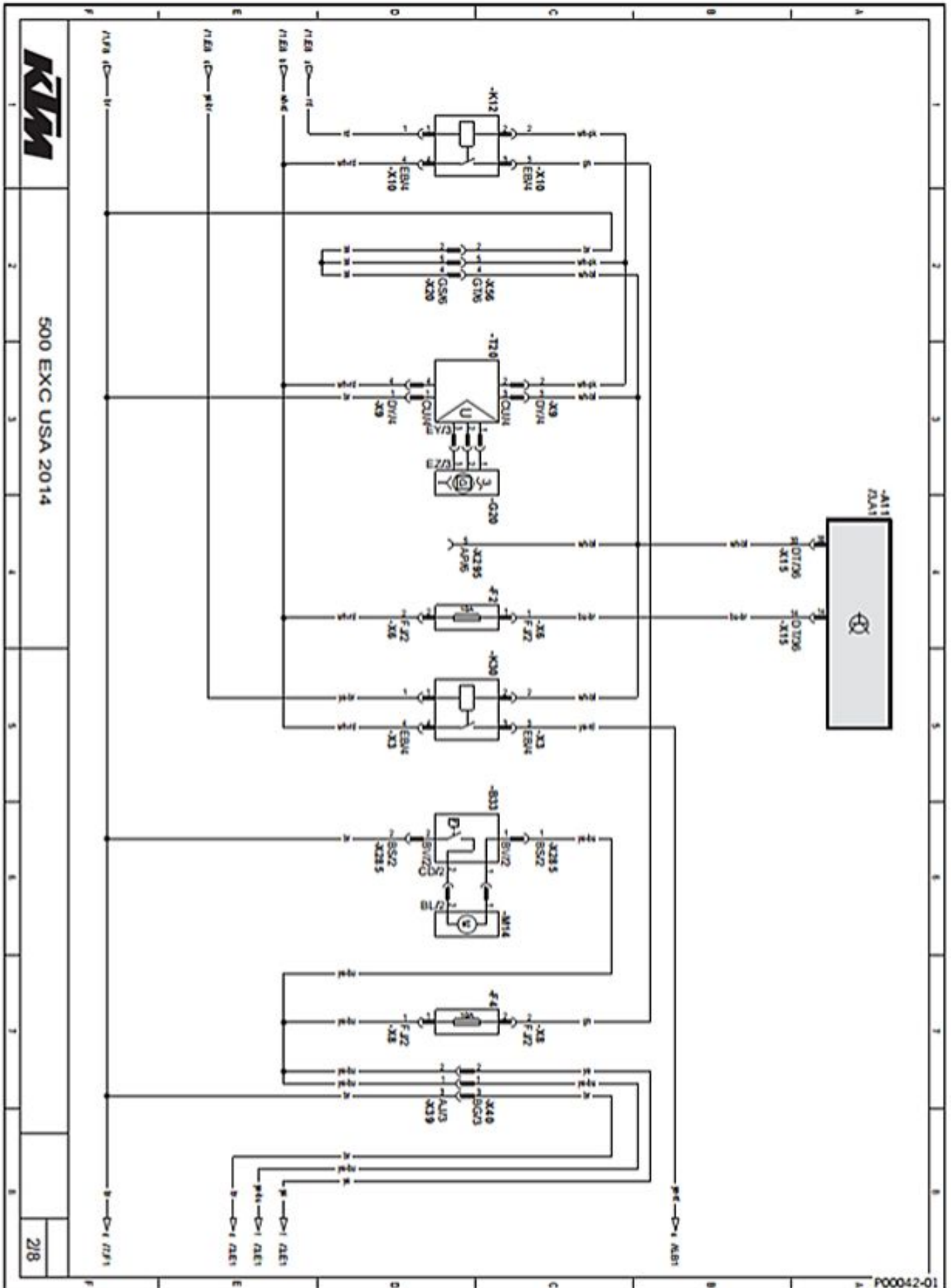

**Components:**

A11	EFI control unit
B33	Radiator fan temperature switch
F2	Fuse
F4	Fuse
G20	Alternator
K12	Light relay
K30	Power relay
M14	Radiator fan
T20	Voltage regulator
X295	Diagnostics connector

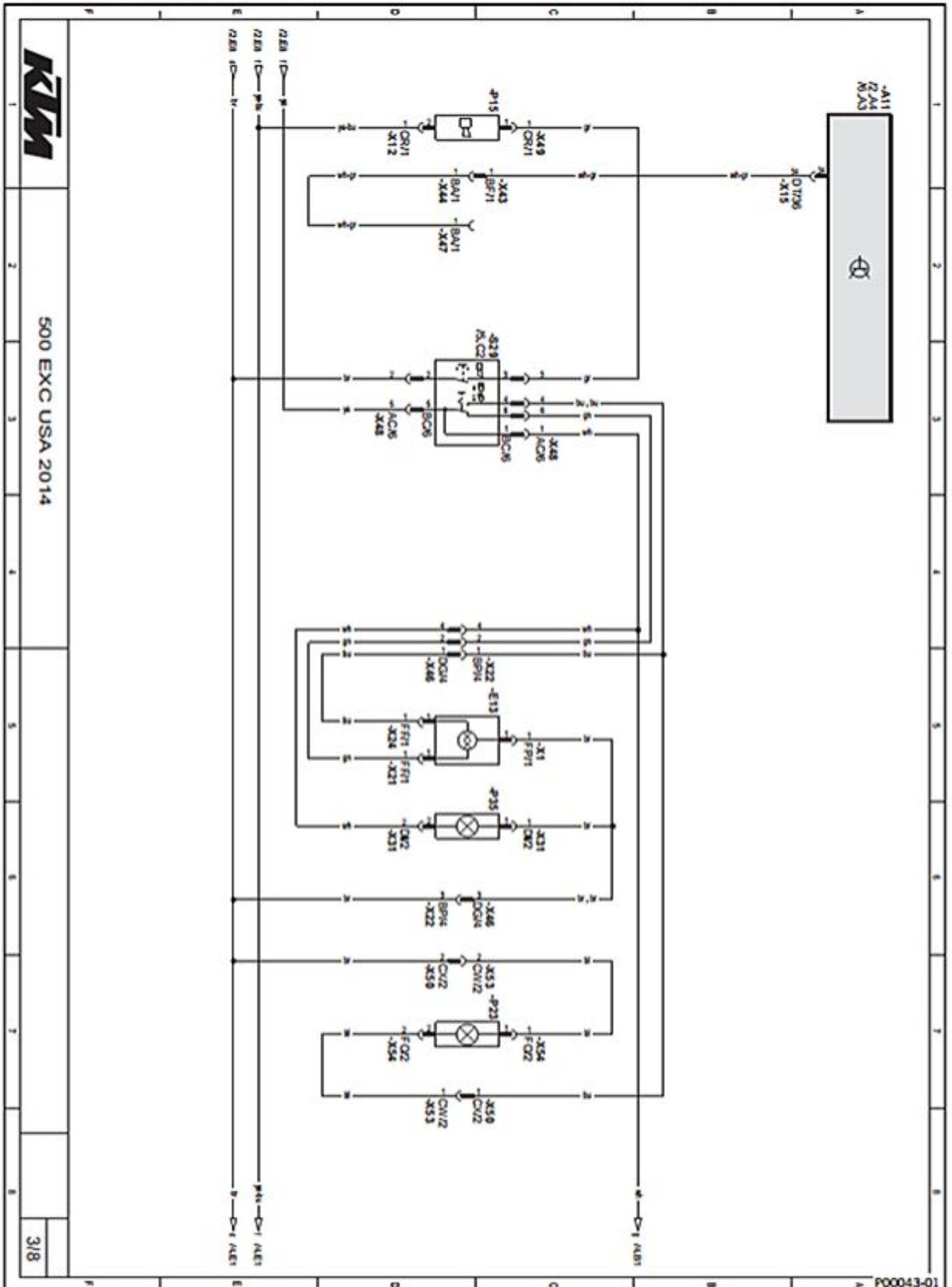

500 EXC USA 2014



**Components:**

A11	EFI control unit
E13	Low beam, high beam
P15	Horn
P23	High beam indicator lamp
P35	Parking light
S29	Light switch, horn button, turn signal switch

29.20 Page 4 of 8 (500 EXC US)

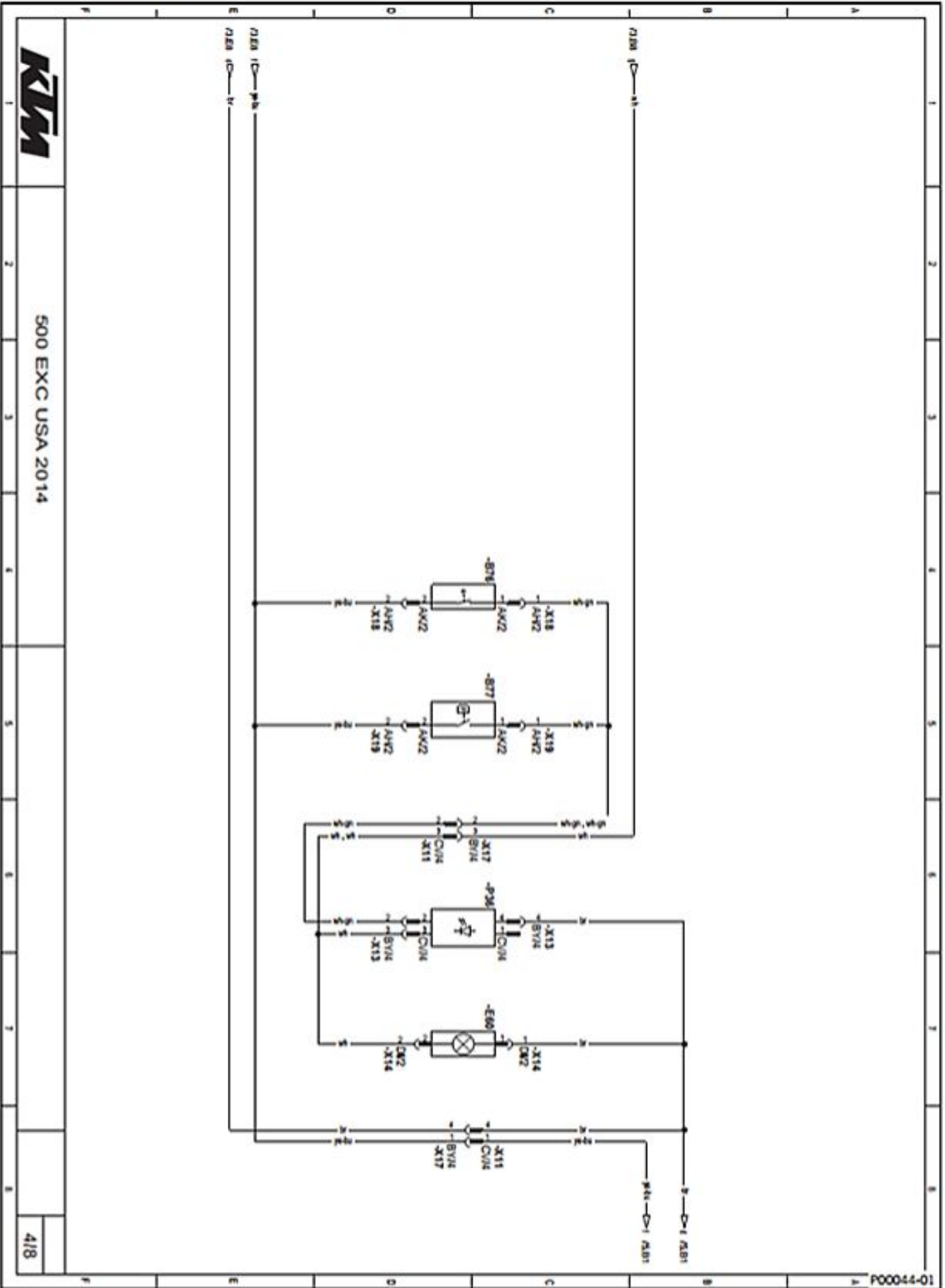

500 EXC USA 2014

**Components:**

---

B76	Front brake light switch
-----	--------------------------

---

B77	Rear brake light switch
-----	-------------------------

---

E60	License plate lamp
-----	--------------------

---

P36	Brake/tail light
-----	------------------

---

29.21 Page 5 of 8 (500 EXC US)

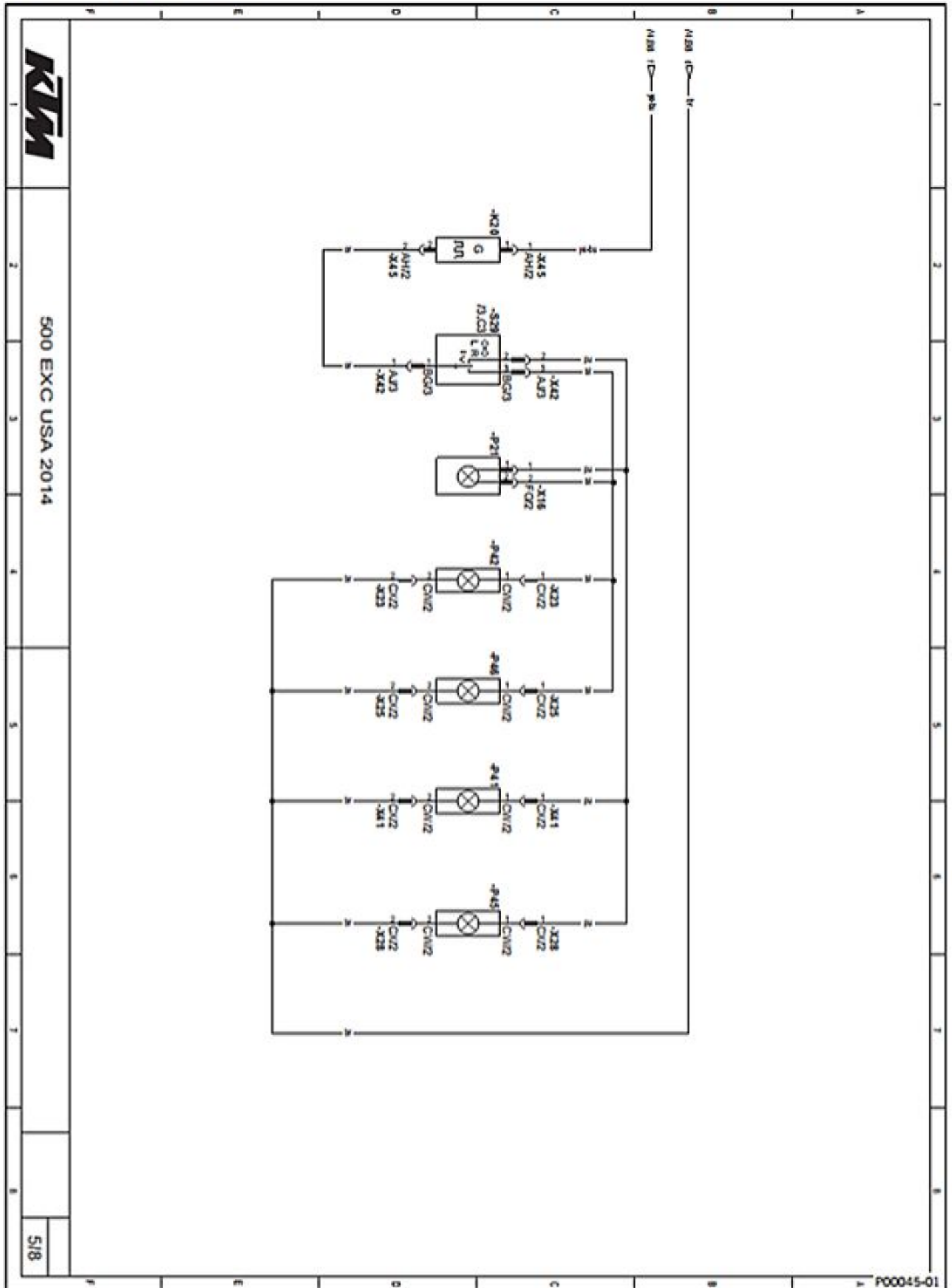

500 EXC USA 2014

**Components:**

K20	Turn signal relay
P21	Turn signal switch
P41	Turn signal, front left
P42	Turn signal, front right
P45	Turn signal, rear left
P46	Turn signal, rear right
S29	Light switch, horn button, turn signal switch

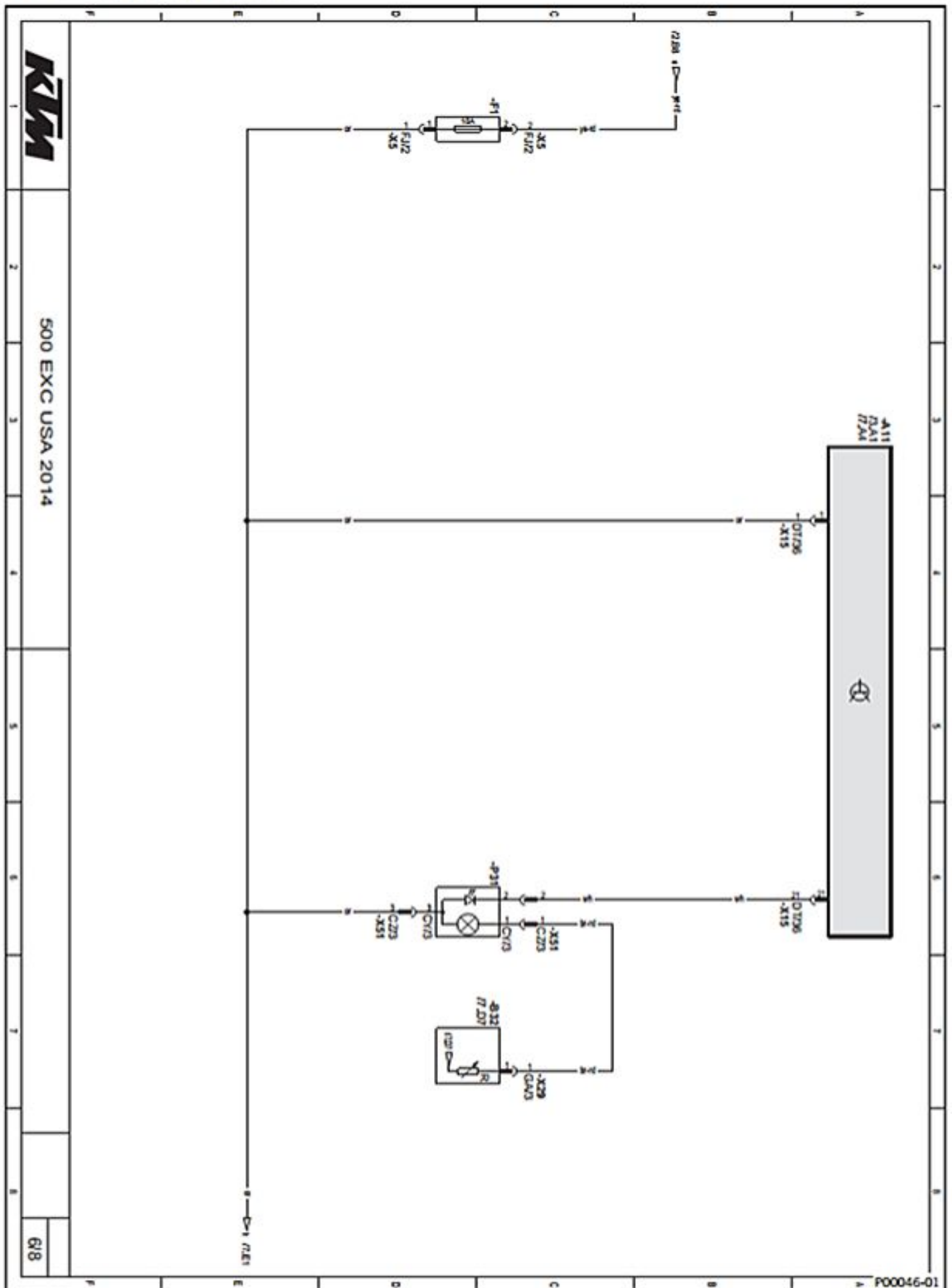

**Components:**

A11	EFI control unit
B32	Fuel level sensor
F1	Fuse
P31	FI warning lamp and low fuel warning lamp

29.23 Page 7 of 8 (500 EXC US)

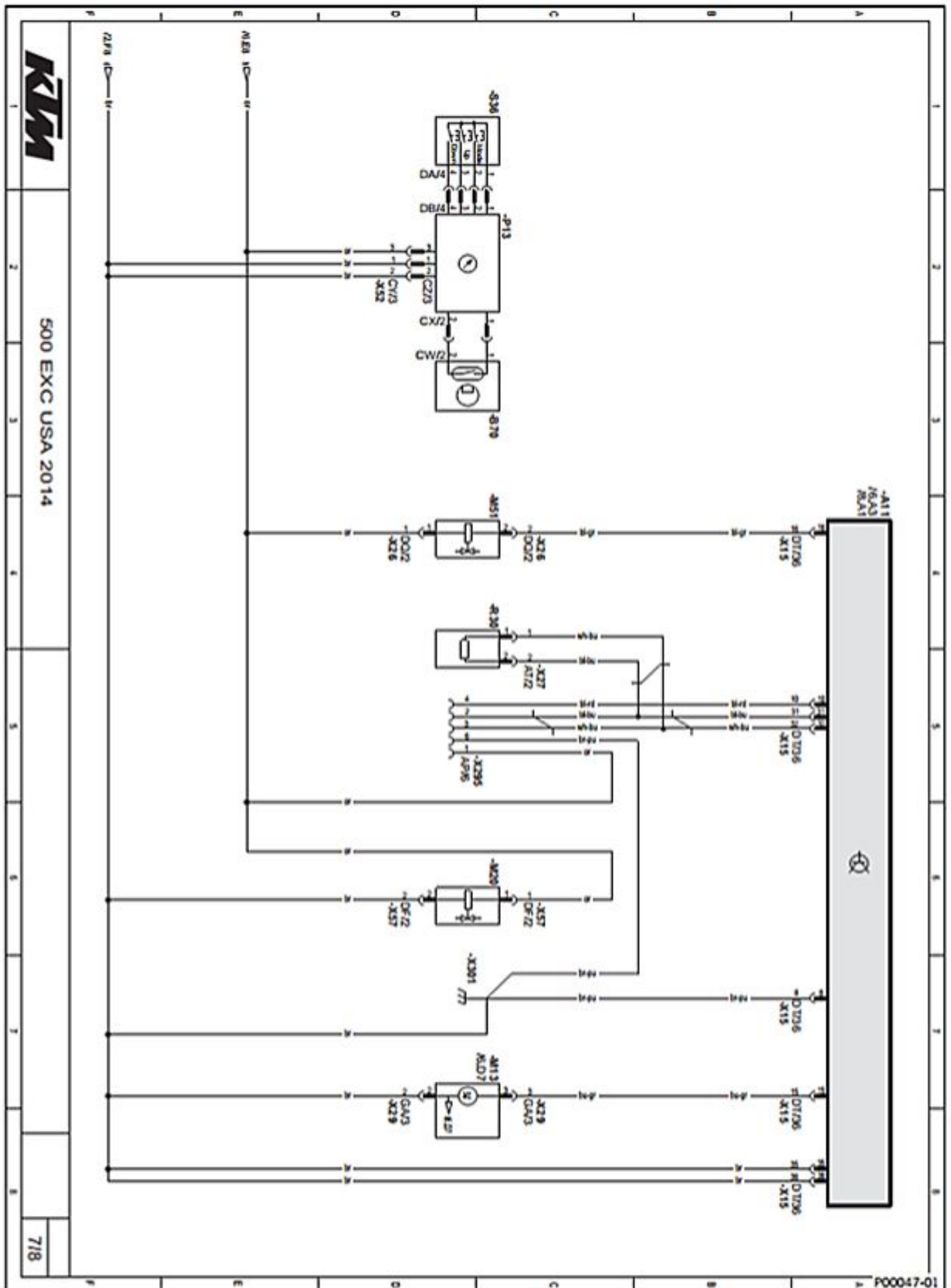



**Components:**

A11	EFI control unit
B70	Front wheel speed sensor
M13	Fuel pump
M20	Fuel evaporation valve
M51	Injector cylinder 1
P13	Speedometer
S36	Tripmaster switch
R30	CAN-bus terminating resistor 1
X295	Diagnostics connector

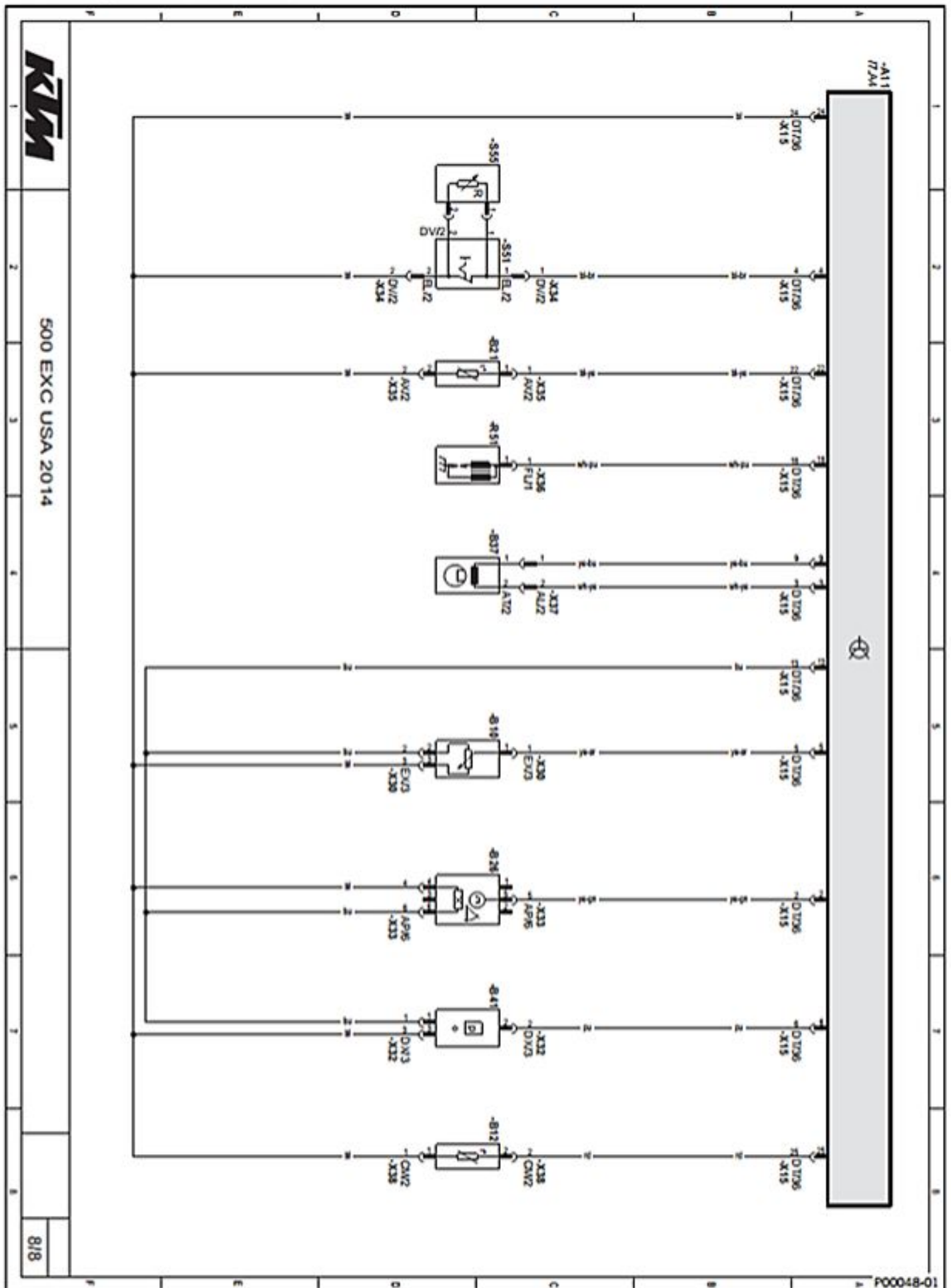

**Components:**

A11	EFI control unit
B10	Throttle position sensor circuit A
B12	Intake air temperature sensor
B21	Engine coolant temperature sensor (cylinder 1)
B26	Rollover sensor
B37	Ignition pulse generator
B41	Manifold absolute pressure sensor (cylinder 1)
R51	Ignition coil (cylinder 1)
S51	<b>Map-Select</b> switch for riding mode (optional)
S55	<b>Map-Select</b> switch for basic setting (optional)

**Cable colors:**

bl	Black
br	Brown
bu	Blue
gn	Green
gr	Gray
lbu	Light blue
or	Orange
pk	Pink
pu	Violet
rd	Red
wh	White
ye	Yellow

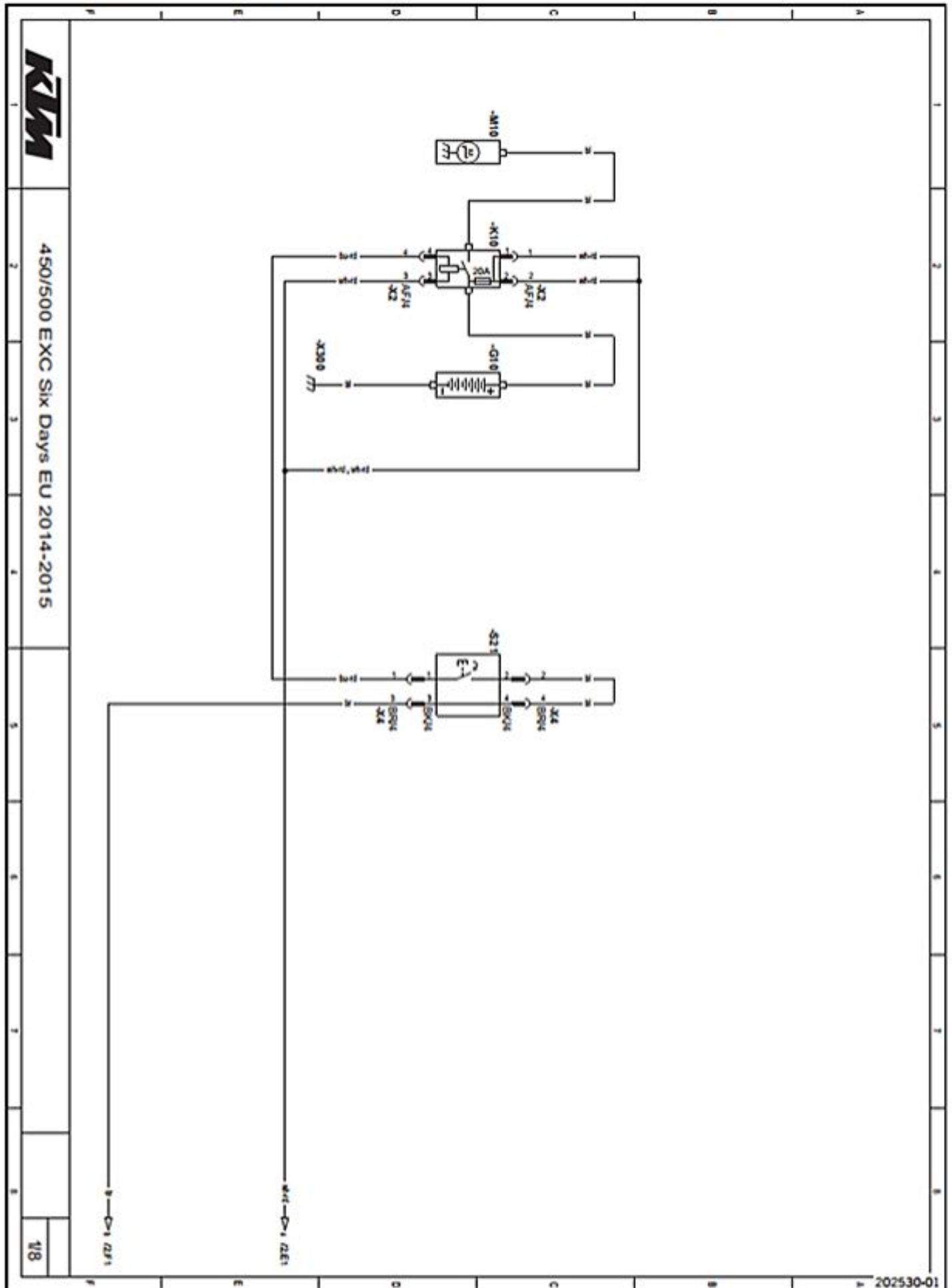

**Components:**

G10	Battery
K10	Starter relay with main fuse
M10	Starter motor
S21	Electric starter button

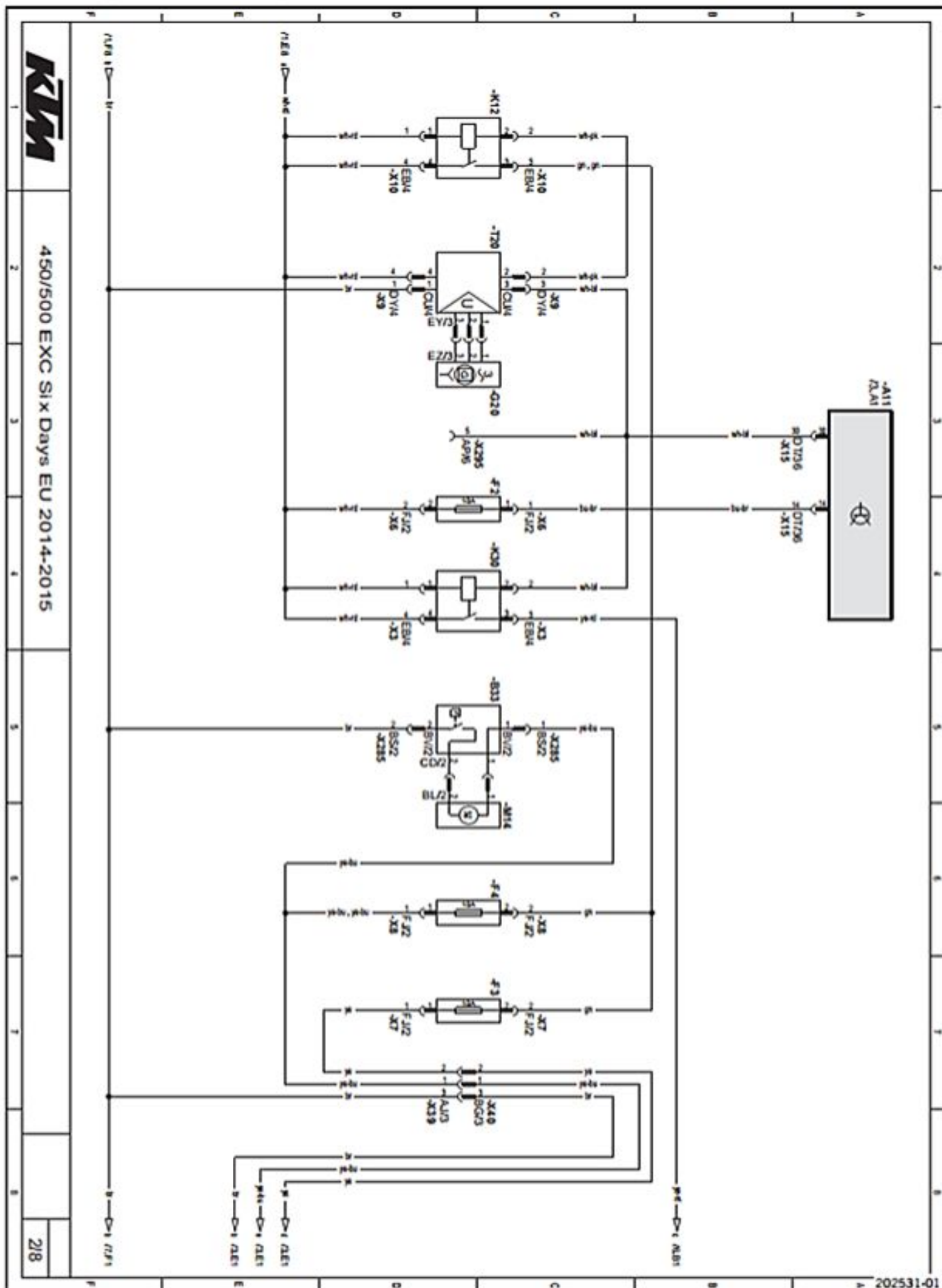

450/500 EXC Six Days EU 2014-2015

**Components:**

A11	EFI control unit
B33	Radiator fan temperature switch
F2	Fuse
F3	Fuse
F4	Fuse
G20	Alternator
K12	Light relay
K30	Power relay
M14	Radiator fan
T20	Voltage regulator
X295	Diagnostics connector

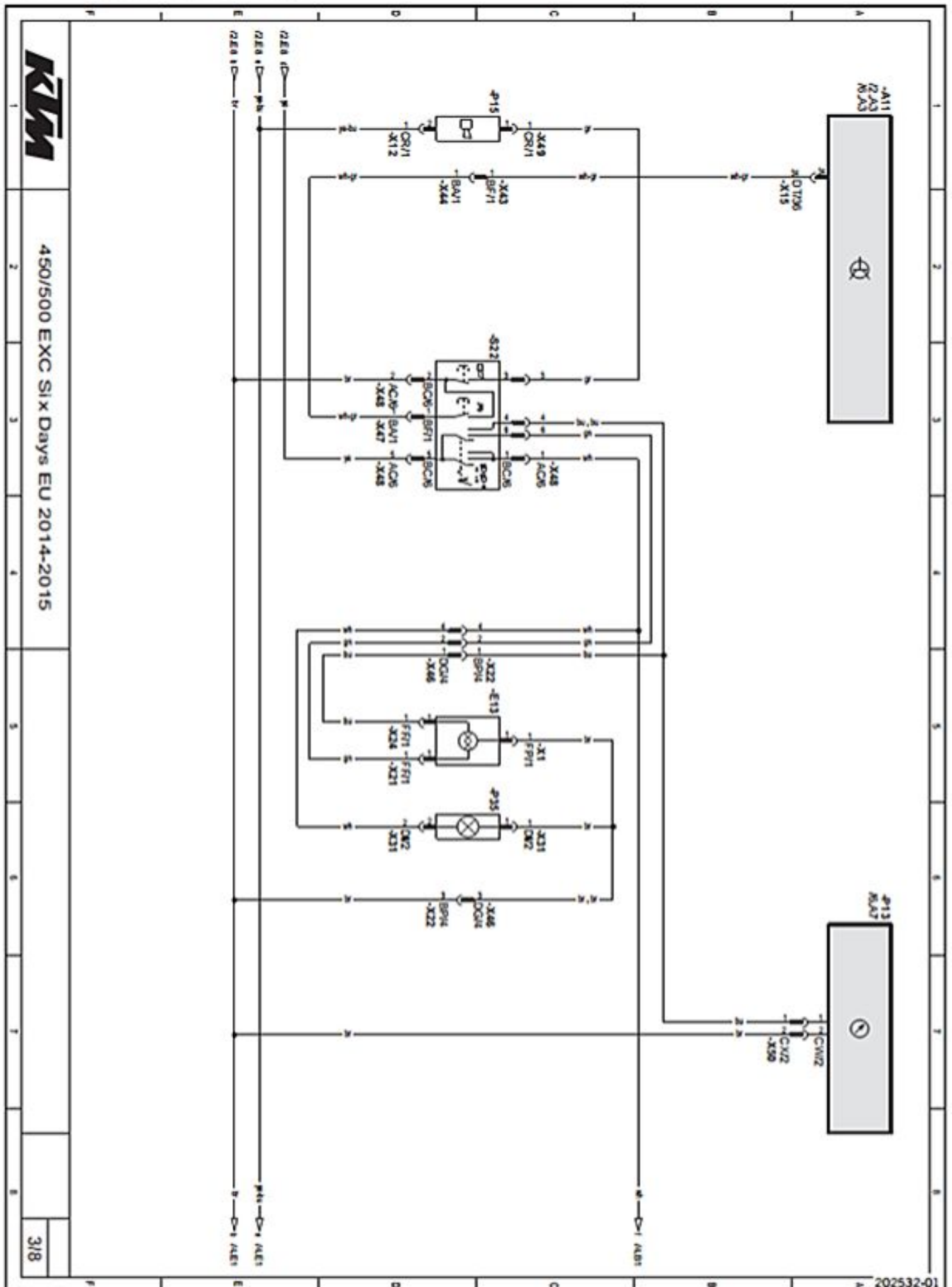



**Components:**

A11	EFI control unit
E13	Low beam, high beam
P13	Speedometer
P15	Horn
P35	Parking light
S22	Light switch, horn button, kill switch

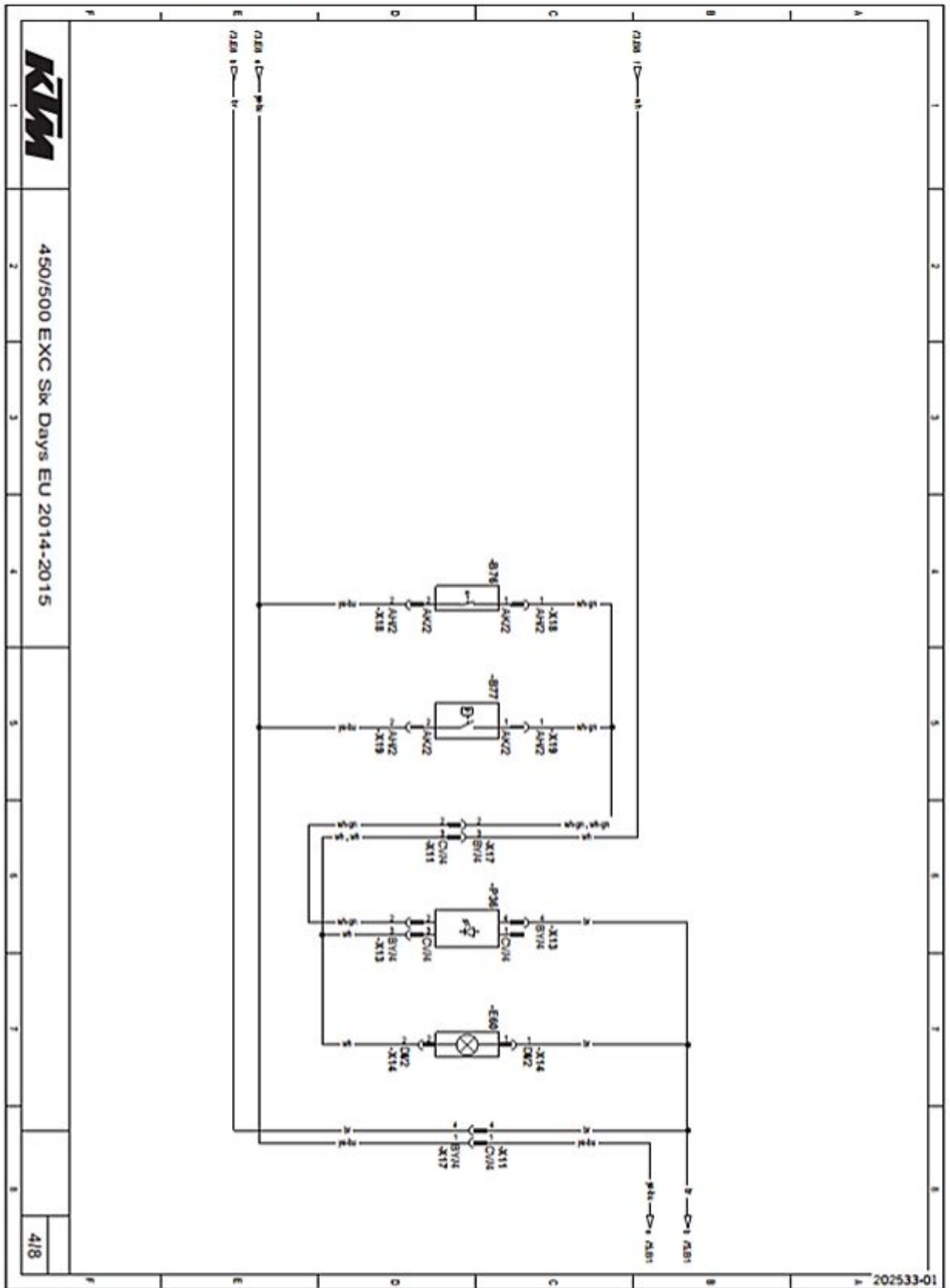

450/500 EXC Six Days EU 2014-2015

**Components:**

---

B76	Front brake light switch
-----	--------------------------

---

B77	Rear brake light switch
-----	-------------------------

---

E60	License plate lamp
-----	--------------------

---

P36	Brake/tail light
-----	------------------

---

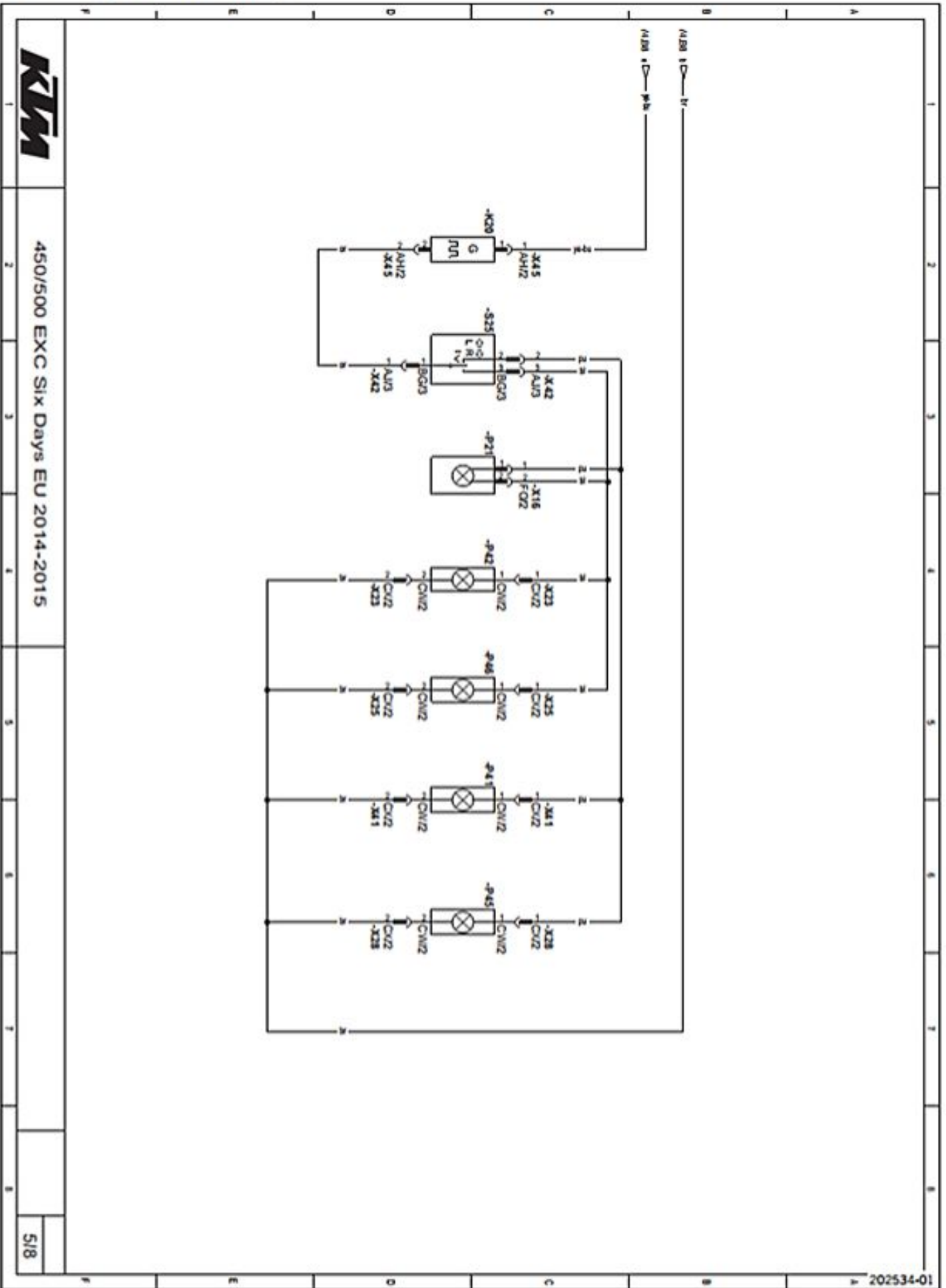

450/500 EXC Six Days EU 2014-2015

**Components:**

K20	Turn signal relay
P21	Turn signal indicator light
P41	Turn signal, front left
P42	Turn signal, front right
P45	Turn signal, rear left
P46	Turn signal, rear right
S25	Turn signal switch

29.30 Page 6 of 8 (EXC Six Days)

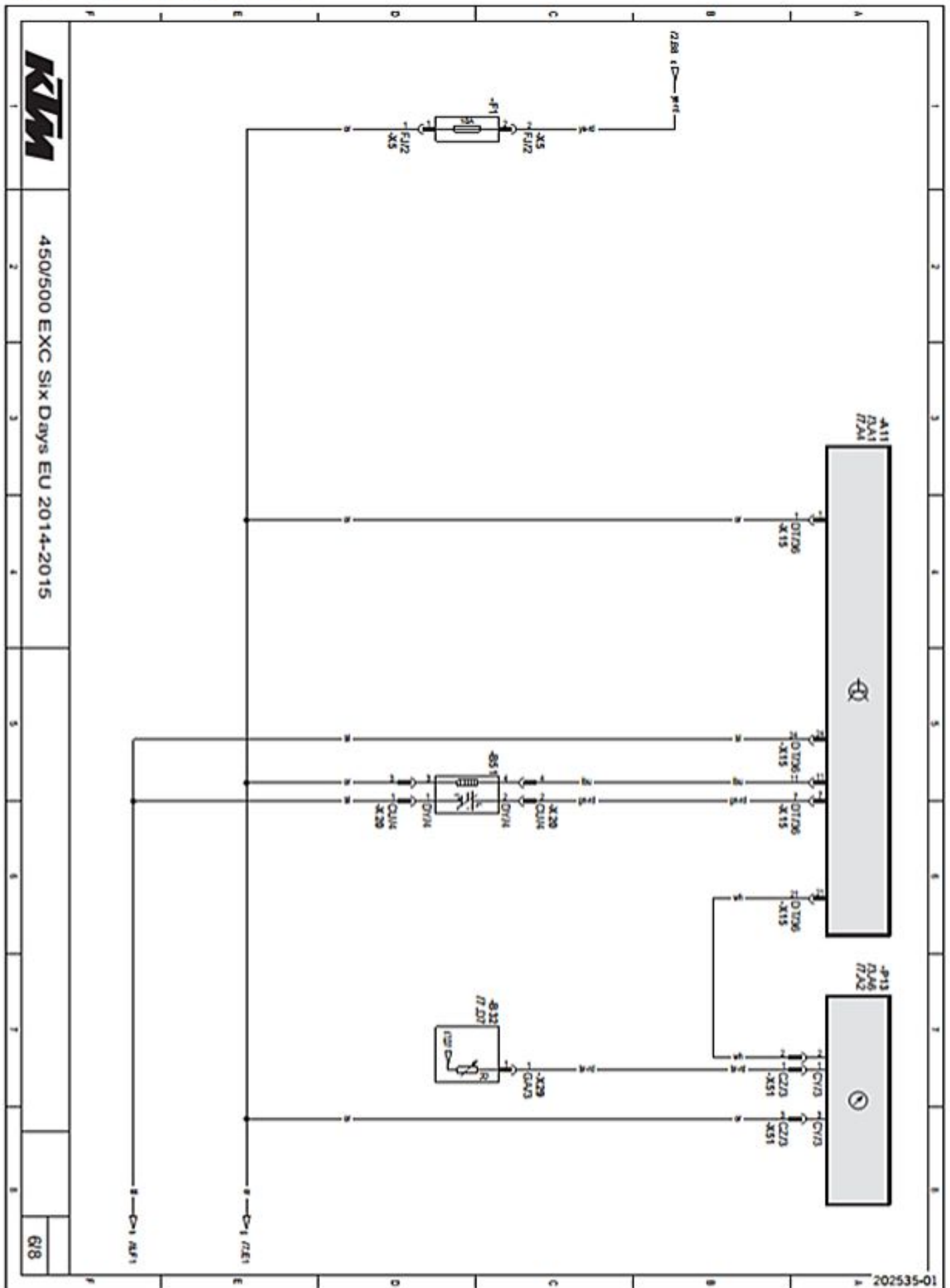

**Components:**

A11	EFI control unit
B32	Fuel level sensor
B51	Lambda sensor (cylinder 1)
F1	Fuse
P13	Speedometer

29.31 Page 7 of 8 (EXC Six Days)

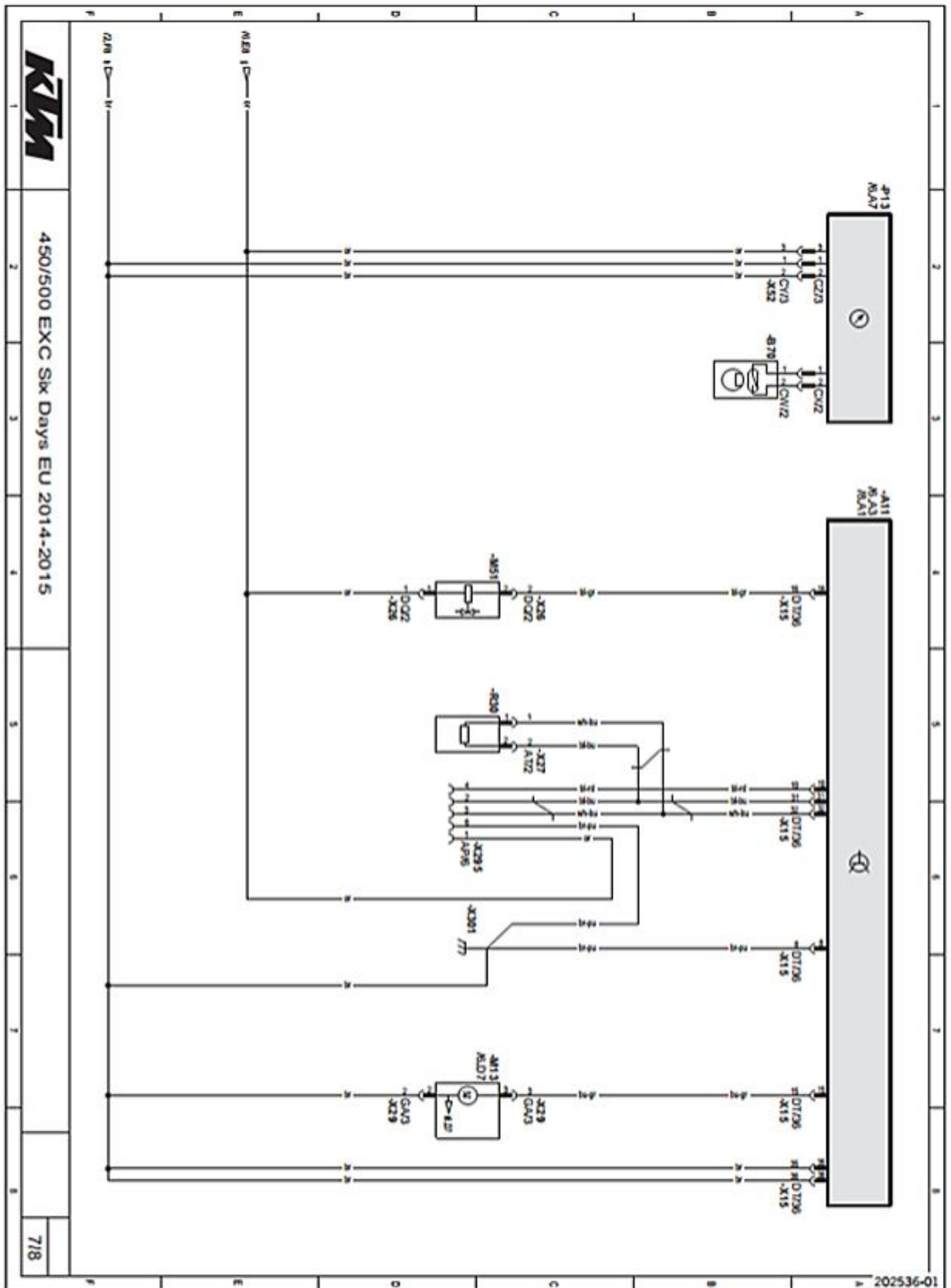



**Components:**

A11	EFI control unit
B70	Front wheel speed sensor
M13	Fuel pump
M51	Injector (cylinder 1)
R30	CAN-bus terminating resistor 1
P13	Speedometer
X295	Diagnostics connector

29.32 Page 8 of 8 (EXC Six Days)

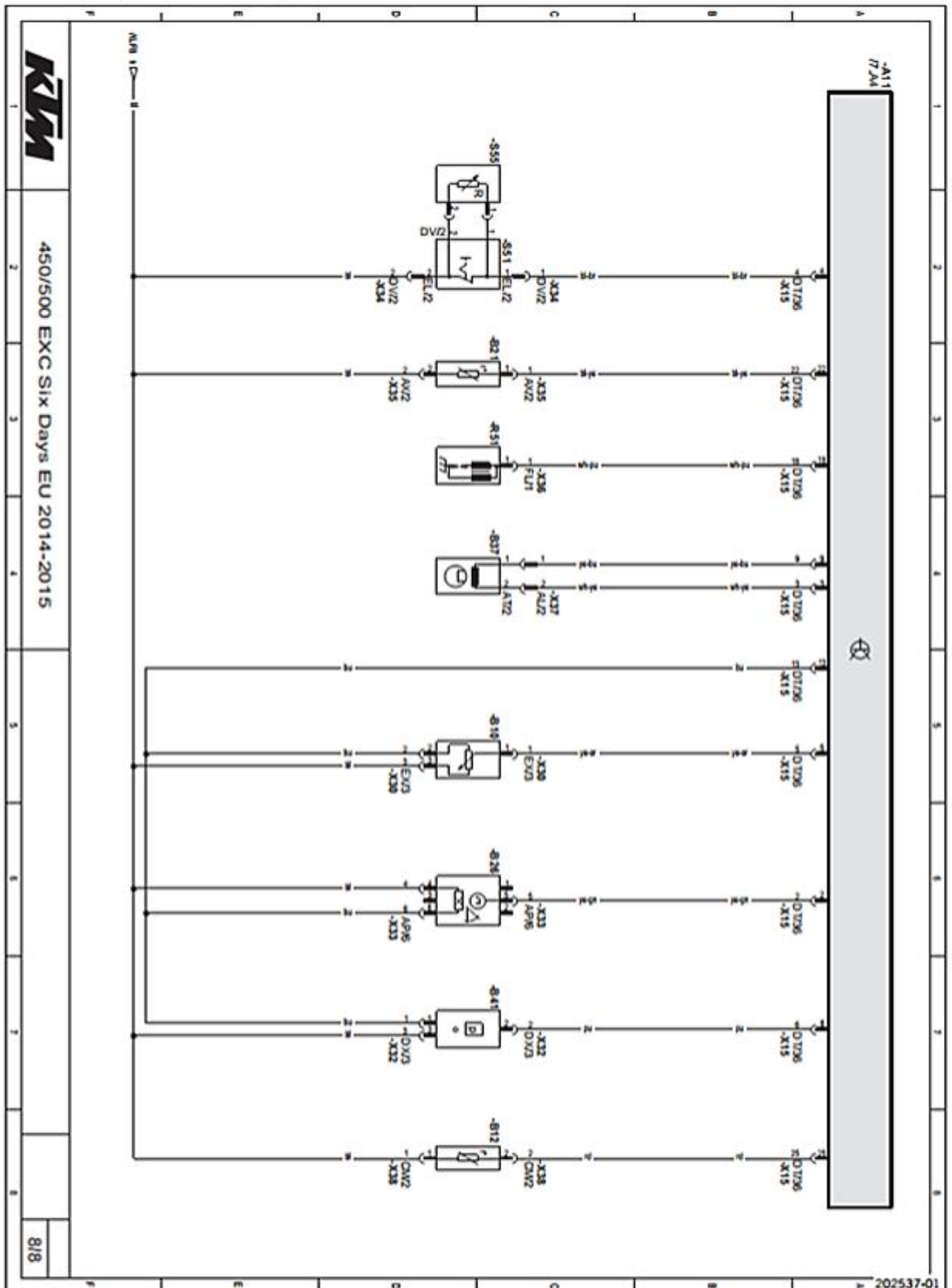

**Components:**

A11	EFI control unit
B10	Throttle position sensor circuit A
B12	Intake air temperature sensor
B21	Engine coolant temperature sensor (cylinder 1)
B26	Rollover sensor
B37	Crankshaft position sensor
B41	Manifold absolute pressure sensor (cylinder 1)
R51	Ignition coil (cylinder 1)
S51	<b>Map-Select</b> switch for driving mode (optional)
S55	<b>Map-Select</b> switch for basic position (optional)

**Cable colors:**

bl	Black
br	Brown
bu	Blue
gn	Green
gr	Gray
lbu	Light blue
or	Orange
pk	Pink
pu	Violet
rd	Red
wh	White
ye	Yellow

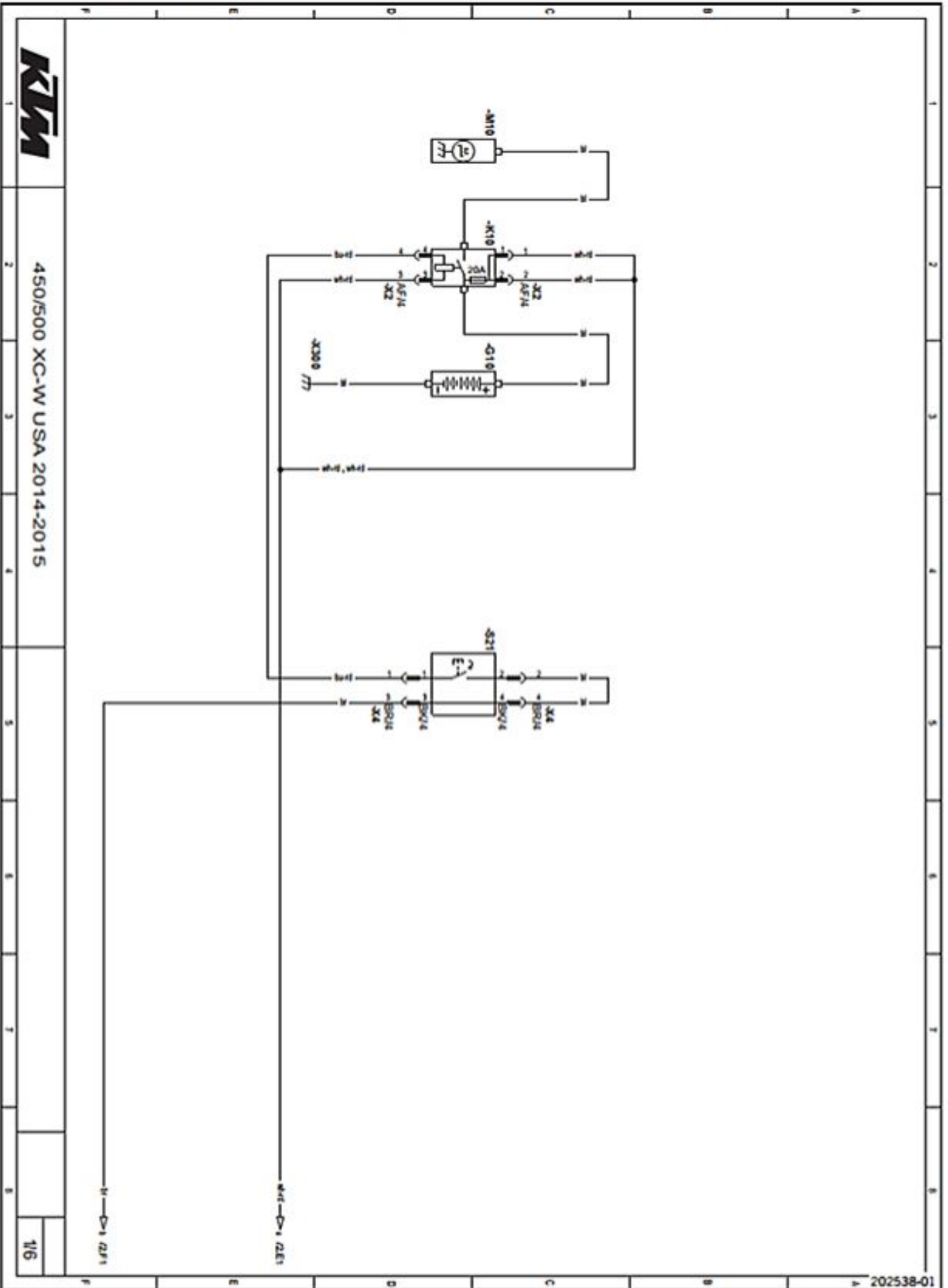

**Components:**

G10	Battery
K10	Starter relay with main fuse
M10	Starter motor
S21	Electric starter button

29.34 Page 2 of 6 (XC-W)

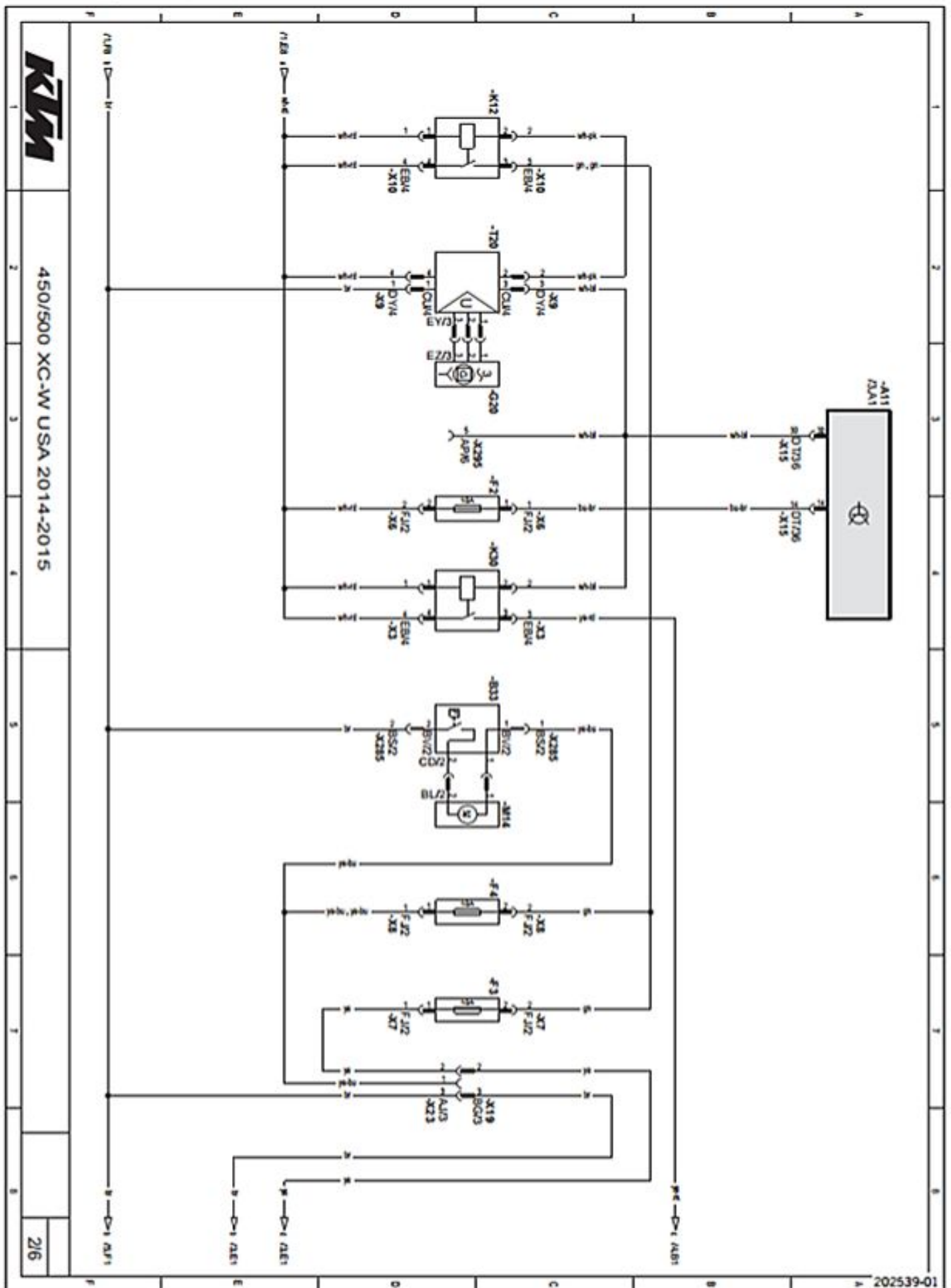

450/500 XC-W USA 2014-2015

**Components:**

A11	EFI control unit
B33	Radiator fan temperature switch
F2	Fuse
F3	Fuse
F4	Fuse
G20	Alternator
K12	Light relay
K30	Power relay
M14	Radiator fan
T20	Voltage regulator
X295	Diagnostics connector

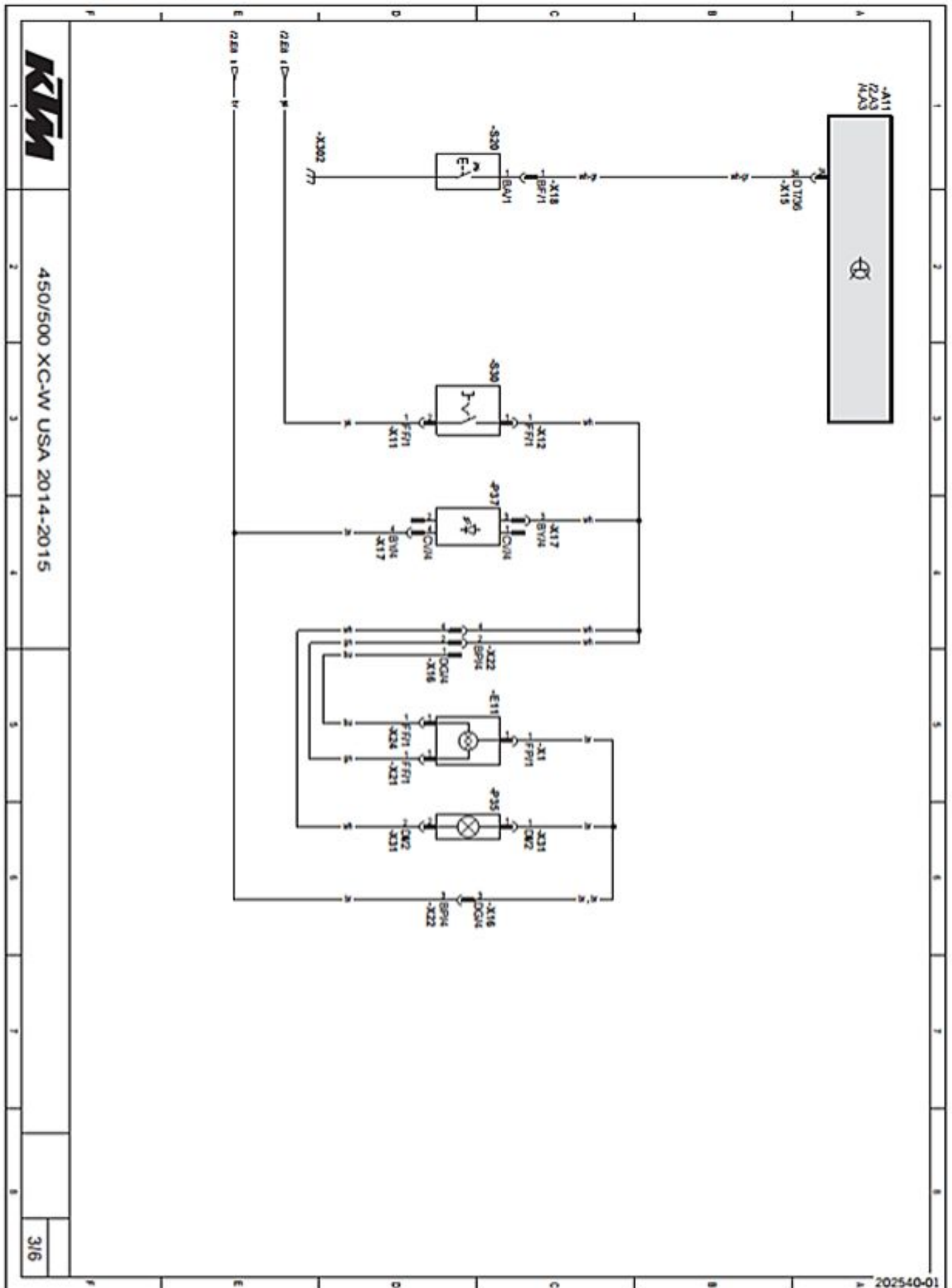

450/500 XC-W USA 2014-2015



**Components:**

A11	EFI control unit
E11	Low beam
P35	Parking light
P37	Tail light
S20	Kill switch
S30	Light switch



**Components:**

A11	EFI control unit
B32	Fuel level sensor
F1	Fuse
P31	FI warning lamp and low fuel warning lamp



**Components:**

A11	EFI control unit
B70	Front wheel speed sensor
M13	Fuel pump
M51	Injector (cylinder 1)
R30	CAN-bus terminating resistor 1
P13	Speedometer
S36	Tripmaster switch
X295	Diagnostics connector

29.38 Page 6 of 6 (XC-W)

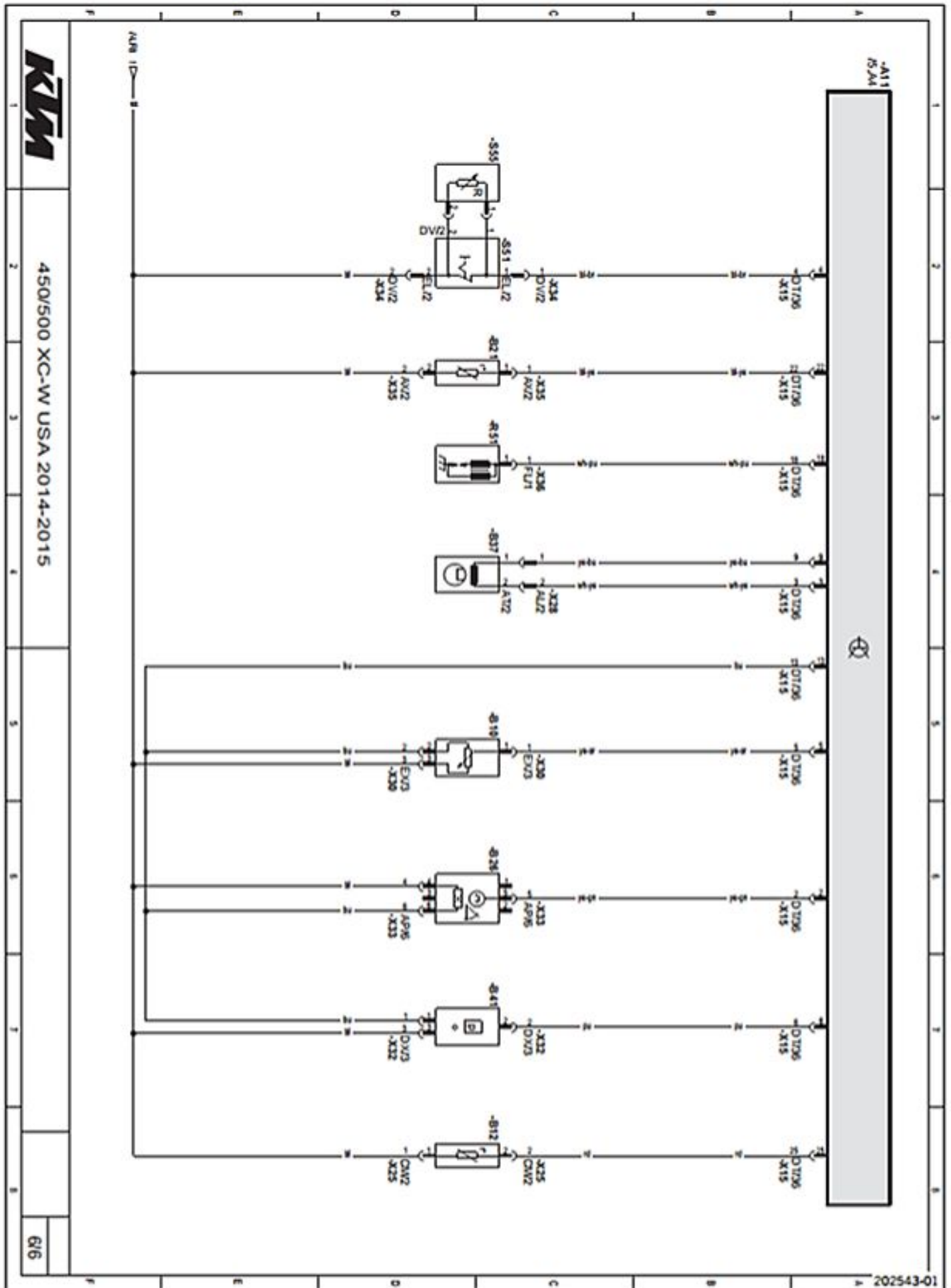

450/500 XC-W USA 2014-2015

**Components:**

A11	EFI control unit
B10	Throttle position sensor circuit A
B12	Intake air temperature sensor
B21	Engine coolant temperature sensor (cylinder 1)
B26	Rollover sensor
B37	Crankshaft position sensor
B41	Manifold absolute pressure sensor (cylinder 1)
R51	Ignition coil (cylinder 1)
S51	<b>Map-Select</b> switch for driving mode (optional)
S55	<b>Map-Select</b> switch for basic position (optional)

**Cable colors:**

bl	Black
br	Brown
bu	Blue
gn	Green
gr	Gray
lbu	Light blue
or	Orange
pk	Pink
pu	Violet
rd	Red
wh	White
ye	Yellow

**Brake fluid DOT 4 / DOT 5.1****Standard/classification**

- DOT

**Guideline**

- Use only brake fluid that complies with the specified standard (see specifications on the container) and that exhibits the corresponding properties.

**Recommended supplier****Castrol**

- RESPONSE BRAKE FLUID SUPER DOT 4

**Motorex®**

- Brake Fluid DOT 5.1

**Coolant****Guideline**

- Only use high quality coolant with corrosion inhibitor for aluminum motors (even in countries with high temperatures). Using inferior antifreeze can result in corrosion and foaming.

**Mixture ratio**

Antifreeze protection: -25... -45 °C (-13... -49 °F)	anti-corrosion/antifreeze distilled water
--	--

**Recommended supplier****Motorex®**

- COOLANT M3.0

**Engine oil (SAE 10W/50)****Standard/classification**

- JASO T903 MA (☛ p. 327)
- SAE (☛ p. 327) (SAE 10W/50)

**Guideline**

- Use only engine oils that comply with the specified standards (see specifications on the container) and that possess the corresponding properties.

Synthetic engine oil
----------------------

**Recommended supplier****Motorex®**

- Cross Power 4T

**Fork oil (SAE 4) (48601166S1)****Standard/classification**

- SAE (☛ p. 327) (SAE 4)

**Guideline**

- Use only oils that comply with the specified standards (see specifications on the container) and that exhibit the corresponding properties.

**Shock absorber fluid (SAE 2.5) (50180751S1)****Standard/classification**

- SAE (☛ p. 327) (SAE 2.5)

**Guideline**

- Use only oils that comply with the specified standards (see specifications on the container) and that exhibit the corresponding properties.

**Super unleaded (ROZ 95/RON 95/PON 91)****Standard/classification**

- DIN EN 228 (ROZ 95/RON 95/PON 91)

**Guideline**

- Only use unleaded super fuel that matches or is equivalent to the specified fuel grade.
- Fuel with an ethanol content of up to 10 % (E10 fuel) is safe to use.

**Info**

Do not use fuel containing methanol (e. g. M15, M85, M100) or more than 10 % ethanol (e. g. E15, E25, E85, E100).



### Air filter cleaner

Recommended supplier

Motorex®

- Racing Bio Dirt Remover

### Chain cleaner

Recommended supplier

Motorex®

- Chain Clean

### Fuel additive

Recommended supplier

Motorex®

- Fuel Stabilizer

### High viscosity grease

Recommended supplier

SKF®

- LGHB 2

### Long-life grease

Recommended supplier

Motorex®

- Bike Grease 2000

### Lubricant (T158)

Recommended supplier

Lubcon®

- Turmogrease® PP 300

### Lubricant (T511)

Recommended supplier

Lubcon®

- Turmsilon® GTI 300 P

### Lubricant (T159)

Recommended supplier

Bel-Ray®

- MC-11®

### Lubricant (T625)

Recommended supplier

Molykote®

- 33 Medium

### Lubricant (T152)

Recommended supplier

Bel-Ray®

- Molytube® Anti-Seize

### Motorcycle cleaner

Recommended supplier

Motorex®

- Moto Clean

### Off-road chain spray

Recommended supplier

Motorex®

- Chainlube Offroad

### Oil for foam air filter

Recommended supplier

Motorex®

- Racing Bio Liquid Power

### Preserving materials for paints, metal and rubber

Recommended supplier

Motorex®

- Moto Protect

### Special cleaner for glossy and matte paint finishes, metal and plastic surfaces

Recommended supplier

Motorex®

- Quick Cleaner

### Universal oil spray

Recommended supplier

Motorex®

- Joker 440 Synthetic

### Bleeder cover



Art. no.: 00029013005

### Bleeder cover



Art. no.: 00029013006

### Bleeding device



Art. no.: 00029013100

### Locking screw

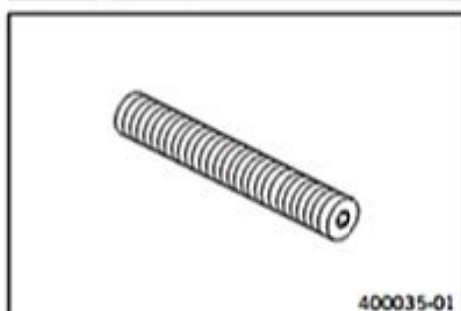

Art. no.: 113080802

### Bearing puller

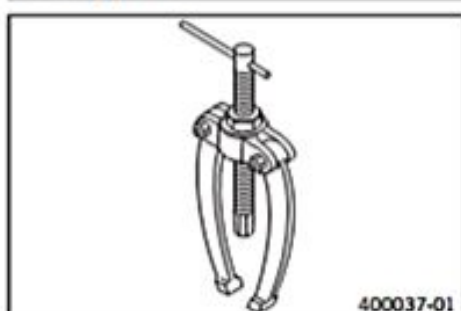

Art. no.: 15112017000

### Insert for bearing puller

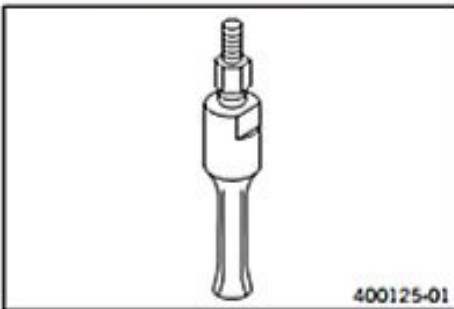

Art. no.: 15112018100

#### Feature

18... 23 mm (0.71... 0.91 in)

### Spring hooks

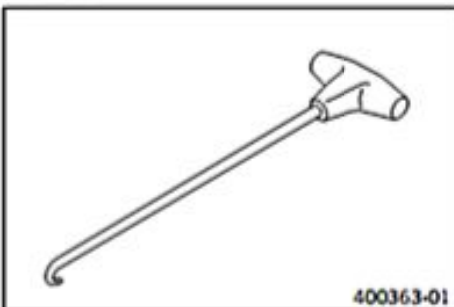

Art. no.: 50305017000

### Mounting tool, heim joint

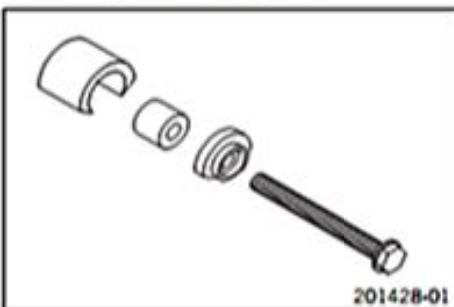

Art. no.: 50329000044

### Bleed syringe



Art. no.: 50329050000

### Circlip pliers reverse



Art. no.: 51012011000

### Clutch holder

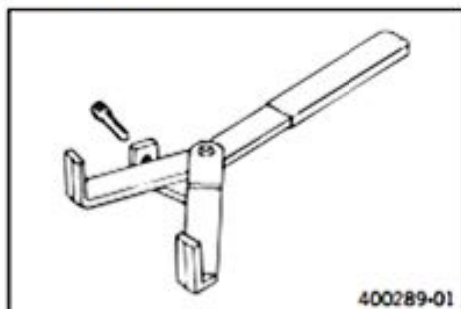

Art. no.: 51129003000

### Lift stand



Art. no.: 54829055000

### Extractor



Art. no.: 58012009000

### Torque wrench with various accessories in set



Art. no.: 58429094000

### Valve spring compressor



Art. no.: 59029019000

### Limit plug gauge

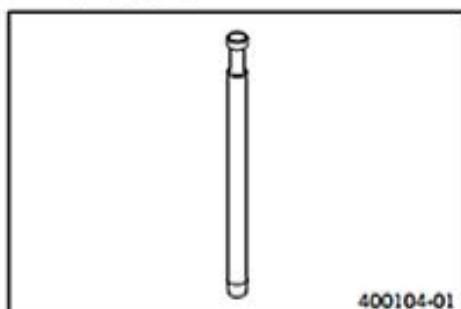

Art. no.: 59029026006

### Feeler gauge

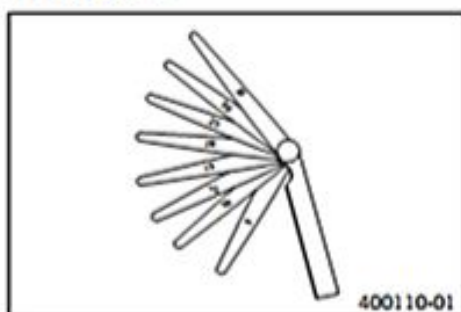

Art. no.: 59029041100

### Piston ring mounting tool

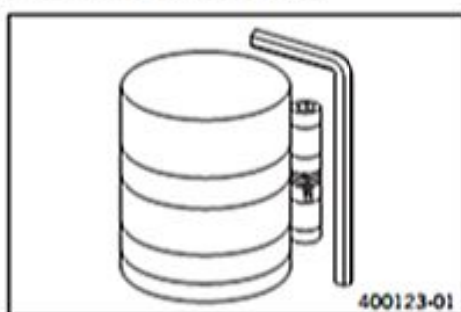

Art. no.: 60029015000

### Puller, 2-arm

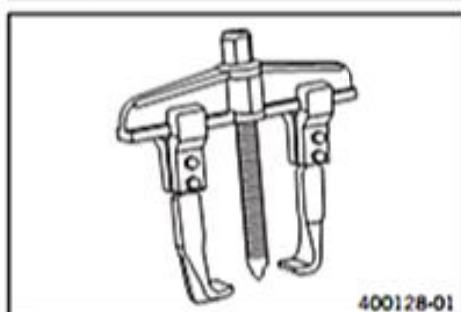

Art. no.: 60029033000

### Hose clamp pliers

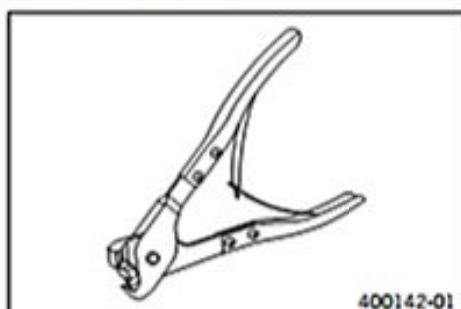

Art. no.: 60029057000

## Testing hose

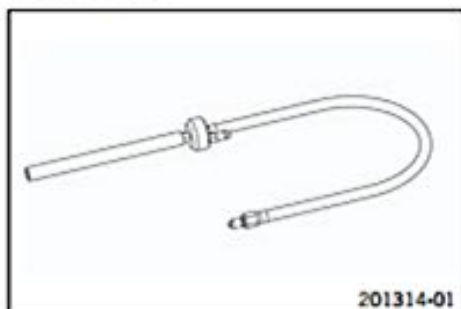

Art. no.: 61029093000

## Pressure testing tool

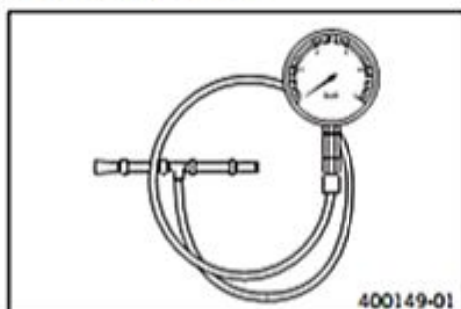

Art. no.: 61029094000

## Engine assembly stand



Art. no.: 61229001000

## Extractor

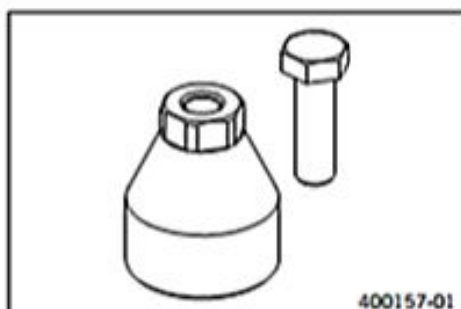

Art. no.: 75029021000

## Push-in drift

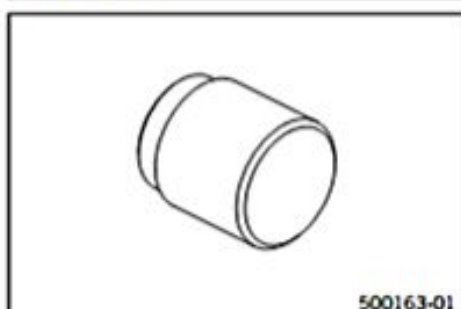

Art. no.: 75029044010

### Push-in drift

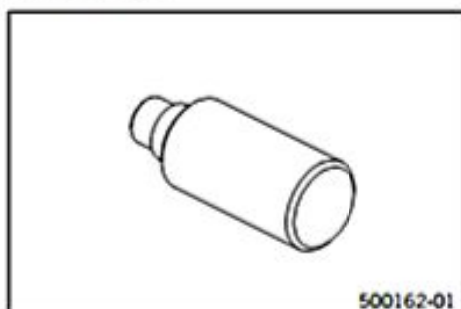

Art. no.: 75029044020

### Pressing device for crankshaft, complete

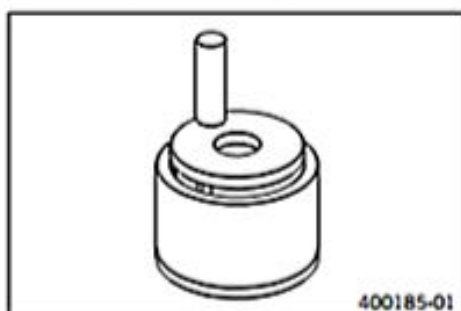

Art. no.: 75029047000

### Clamping plate

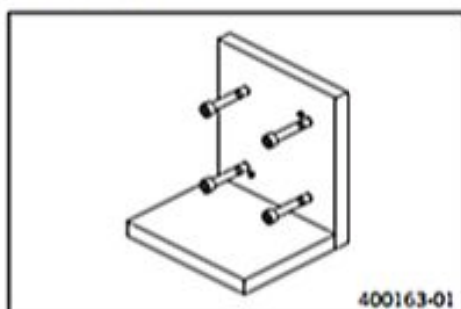

Art. no.: 75029050000

### Push-out drift

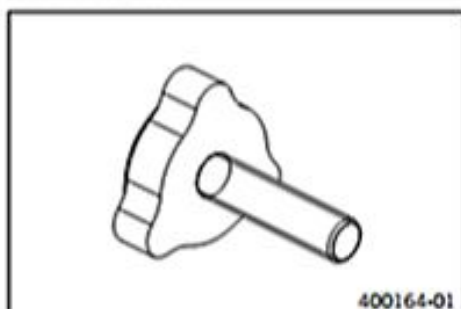

Art. no.: 75029051000

### Protection cover

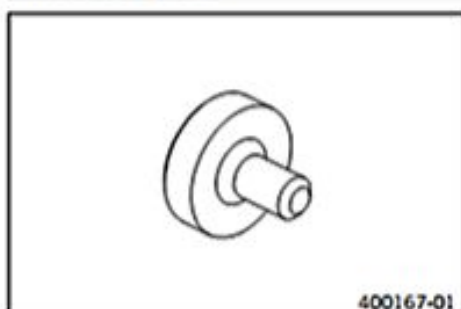

Art. no.: 75029090000



### Oil pressure adapter

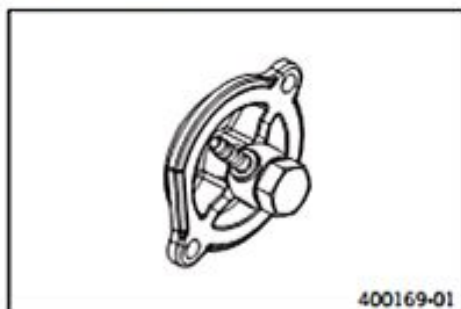

Art. no.: 75029094000

### Spark plug wrench

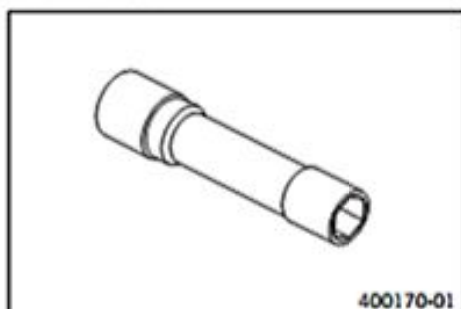

Art. no.: 75029172000

### Limit plug gauge

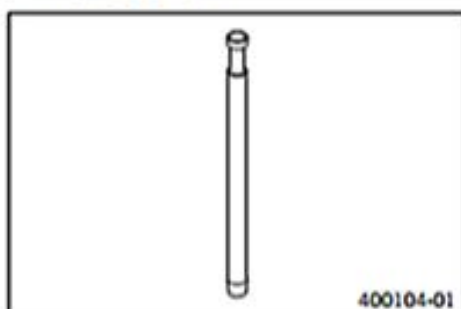

Art. no.: 77029026000

### Insert for valve spring lever



Art. no.: 77029041000

### Insert for piston pin retainer

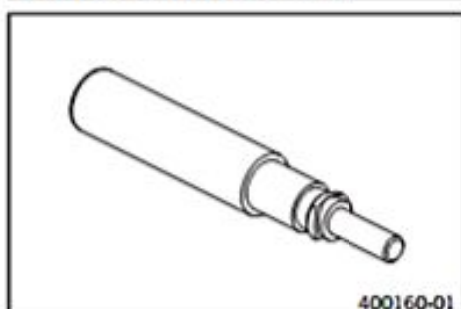

Art. no.: 77329030100

### Engine bracket

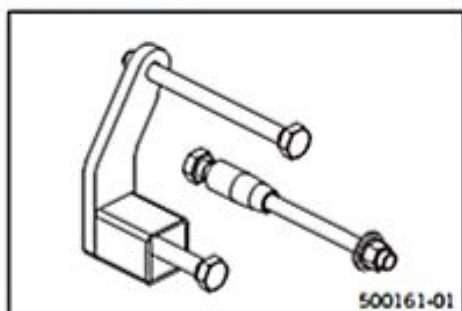

Art. no.: 78029002000

### Mounting sleeve

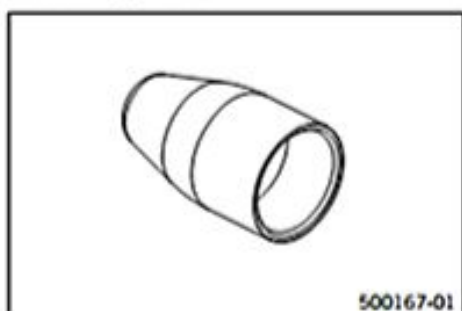

Art. no.: 78029005000

### Insert for crankshaft pressing device

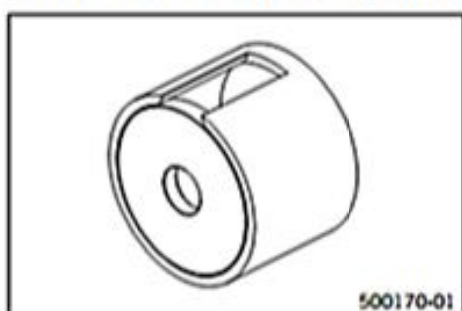

Art. no.: 78029008000

### Separator plate

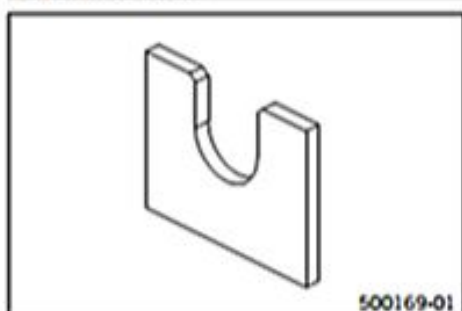

Art. no.: 78029009000

### Removal tool

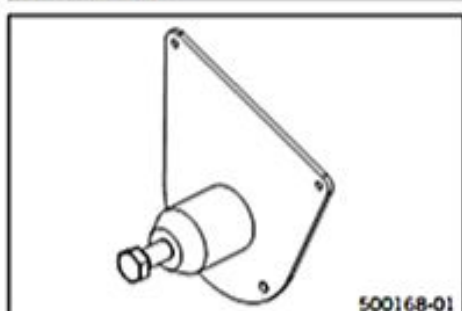

Art. no.: 78029049100

### Fixing drift

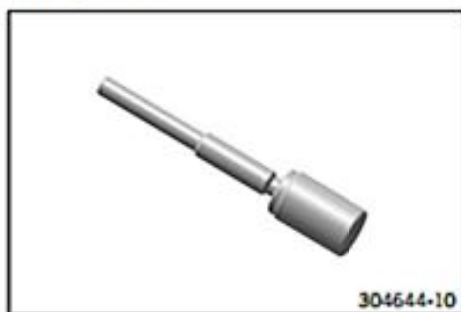

Art. no.: 78129032000

### Gear quadrant

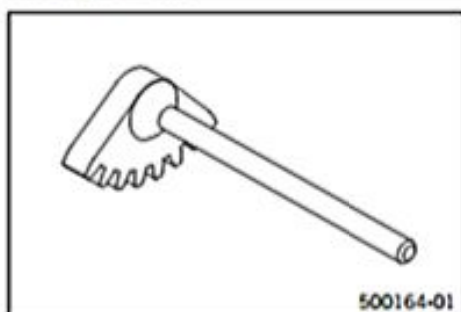

Art. no.: 80029004000

### Mounting sleeve

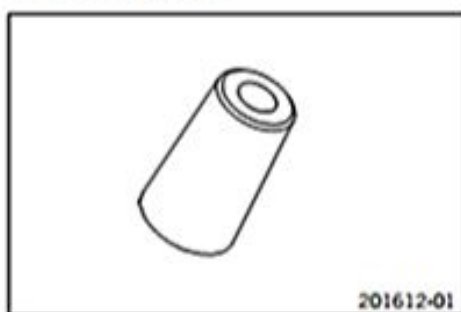

Art. no.: 90129005000

### Case separating tool

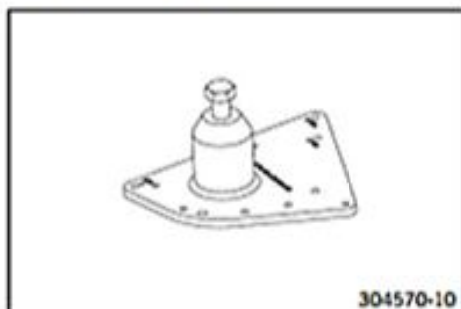

Art. no.: 90129048000

### Pin wrench



Art. no.: T103

### Hook wrench



301085-01

Art. no.: T106S

### Depth micrometer



300577-10

Art. no.: T107S

### Pin



201235-10

Art. no.: T120

### Mounting sleeve



200788-10

Art. no.: T1204

### Calibration pin



200790-10

Art. no.: T1205

### Pressing tool



Art. no.: T1206

### Pressing tool



Art. no.: T1207S

### Centering sleeve



Art. no.: T1214

### Mounting sleeve



Art. no.: T1215

### Disassembly tool



Art. no.: T1216

### Vacuum pump



Art. no.: T1240S

### Protecting sleeve



Art. no.: T1401

### Clamping stand

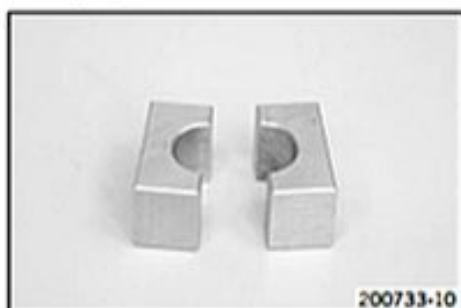

Art. no.: T14015S

### Clamping stand

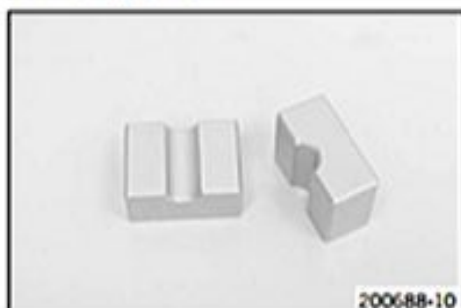

Art. no.: T14016S

### Gripping tool



Art. no.: T14026S1

### Assembly tool



Art. no.: T1402S

### Open-end wrench



Art. no.: T14032

### Clamping stand



Art. no.: T1403S

### Mounting tool



Art. no.: T14040S

### Special socket

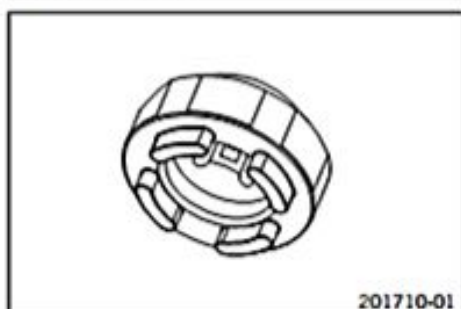

Art. no.: T14047

### Clamping stand

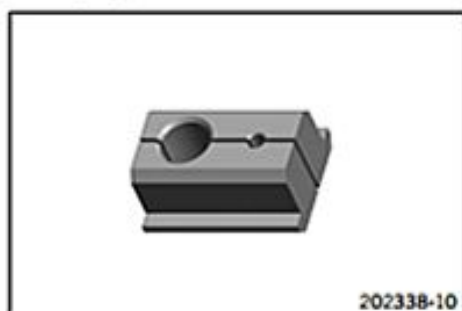

Art. no.: T14049S

### Press-out tool



Art. no.: T14051

### Press drift



Art. no.: T1504

### Assembly tool



Art. no.: T150S

### Nitrogen filling tool



Art. no.: T170S1



### JASO T903 MA

Different technical development directions required a new specification for 4-stroke motorcycles – the JASO T903 MA Standard. Earlier, engine oils from the automobile industry were used for 4-stroke motorcycles because there was no separate motorcycle specification. Whereas long service intervals are demanded for automobile engines, high performance at high engine speeds are in the foreground for motorcycle engines. In most motorcycles, the gearbox and the clutch are lubricated with the same oil as the engine. The JASO MA Standard meets these special requirements.

### SAE

The SAE viscosity classes were defined by the Society of Automotive Engineers and are used for classifying oils according to their viscosity. The viscosity describes only one property of oil and says nothing about quality.

Art. no.	Article number
ca.	circa
cf.	compare
e.g.	for example
etc.	et cetera
i.a.	inter alia
no.	number
poss.	possibly

<b>A</b>	
Accessories .....	8
<b>Air filter</b>	
cleaning .....	91
installing .....	91
removing .....	91
<b>Air filter box</b>	
cleaning .....	91
sealing .....	90
<b>Air filter box cover</b>	
removing .....	90
<b>Air filter box lid</b>	
installing .....	90
<b>Alternator</b>	
stator winding, checking .....	215
<b>Antifreeze</b>	
checking .....	207
<b>Assembling the engine</b>	
crankshaft, installing .....	187
valve clearance, checking .....	201
<b>Auxiliary substances</b> .....	8
<b>B</b>	
<b>Battery</b>	
installing .....	118
removing .....	117
<b>Brake disc</b>	
front brake, installing .....	109
front brake, removing .....	109
rear brake, installing .....	111
rear brake, removing .....	111
<b>Brake discs</b>	
checking .....	107
<b>Brake fluid</b>	
front brake, adding .....	123
front brake, changing .....	124
rear brake, adding .....	128
rear brake, changing .....	129
<b>Brake fluid level</b>	
front brake, checking .....	123
rear brake, checking .....	128
<b>Brake linings</b>	
front brake, changing .....	120
front brake, checking .....	120
rear brake, changing .....	125
rear brake, checking .....	125
<b>C</b>	
<b>Capacity</b>	
coolant .....	209, 224
engine oil .....	145, 212, 224
fuel .....	224
<b>Cartridge</b>	
fork legs, assembling .....	28, 50
fork legs, disassembling .....	24, 44
<b>Chain</b>	
checking .....	113
cleaning .....	115
<b>Chain guide</b>	
checking .....	113
<b>Chain tension</b>	
adjusting .....	112
checking .....	112
<b>Charging voltage</b>	
checking .....	118
<b>Chassis number</b> .....	9
<b>Closed current</b>	
checking .....	118
<b>Clutch</b>	
fluid level, checking/correcting .....	205
fluid, changing .....	205
<b>Clutch lever</b>	
basic position, adjusting .....	59
<b>Compression damping</b>	
fork, adjusting .....	13
<b>Compression damping fitting</b>	
fork legs, assembling .....	27
fork legs, disassembling .....	26
<b>Compression damping, high-speed</b>	
shock absorber, adjusting .....	64
<b>Compression damping, low-speed</b>	
shock absorber, adjusting .....	64
<b>Coolant</b>	
draining .....	208
refilling .....	209
<b>Coolant level</b>	
checking .....	207-208
<b>Cooling system</b> .....	207
<b>Cylinder - Nikasil® coating</b> .....	167
<b>D</b>	
<b>Disassembling the engine</b>	
clutch cover, removing .....	152
oil filter, removing .....	146
torque limiter, removing .....	155
transmission shafts, removing .....	159
<b>E</b>	
<b>Engine</b>	
installing .....	140
removing .....	136
<b>Engine - work on individual parts</b>	
autodecompressor, assembling .....	170
autodecompressor, disassembling .....	169
camshaft bearing, changing .....	173
camshaft, checking .....	171
clutch, checking .....	176
connecting rod, conrod bearing, and crank pin, changing .....	165
countershaft, assembling .....	181
countershaft, disassembling .....	181
crankshaft run-out at the bearing pin, checking .....	167
crankshaft seal ring in the clutch cover, removing .....	163
crankshaft seal ring, installing in clutch cover .....	163
cylinder - Nikasil® coating .....	167
cylinder head, checking .....	174

- cylinder, checking/measuring ..... 167
  - freewheel, checking ..... 186
  - freewheel, installing ..... 186
  - freewheel, removing ..... 185
  - kickstarter shaft, premounting ..... 184
  - left engine case section ..... 161
  - main shaft, assembling ..... 180
  - main shaft, disassembling ..... 179
  - oil pressure regulator valve, installing ..... 163
  - oil pressure regulator valve, removing ..... 162
  - oil pumps, checking ..... 169
  - piston ring end gap, checking ..... 168
  - piston, checking/measuring ..... 168
  - piston/cylinder, determining the mounting clearance .. 169
  - right engine case section ..... 160
  - rocker arm shafts, checking ..... 175
  - rocker arm, installing ..... 176
  - rocker arm, removing ..... 172
  - shift mechanism, checking ..... 178
  - shift shaft, preassembling ..... 179
  - spring length of oil pressure regulator valve, checking . 162
  - starter drive, checking ..... 185
  - timing assembly, checking ..... 171
  - timing chain sprocket, installing ..... 165
  - timing chain sprocket, removing ..... 165
  - transmission, checking ..... 182
  - valve spring seat, checking ..... 174
  - valve springs, checking ..... 174
  - valves, checking ..... 173
  - valves, installing ..... 175
  - valves, removing ..... 172
  - water pump, installing ..... 164
  - water pump, removing ..... 163
- Engine assembly**
- alternator cover, installing ..... 201
  - camshaft, installing ..... 200
  - clutch cover, installing ..... 194
  - clutch discs, installing ..... 193
  - clutch push rod, installing ..... 203
  - cylinder head, installing ..... 199
  - engine, removing from engine assembly stand ..... 204
  - force pump, installing ..... 189
  - freewheel gear, installing ..... 189
  - ignition pulse generator, installing ..... 196
  - kickstarter idler gear, installing ..... 191
  - kickstarter shaft, installing ..... 191
  - kickstarter, installing ..... 202
  - left engine case, installing ..... 188
  - locking lever, installing ..... 190
  - oil filter, installing ..... 203
  - oil pump gear wheels, installing ..... 190
  - oil screen, installing ..... 203
  - outer clutch hub, installing ..... 192
  - piston, installing ..... 197
  - primary gear nut, installing ..... 193
  - primary gear, installing ..... 189
  - rotor, installing ..... 197
  - shift drum locating unit, installing ..... 190
  - shift drum, installing ..... 188
  - shift forks, installing ..... 187
  - shift rails, installing ..... 188
  - shift shaft, installing ..... 191
  - spark plug, installing ..... 202
  - starter idler gear, installing ..... 191
  - starter motor, installing ..... 202
  - suction pump, installing ..... 195
  - timing chain guide rail, installing ..... 197
  - timing chain securing guide, installing ..... 196
  - timing chain tensioner, installing ..... 200
  - timing chain tensioning rail, installing ..... 197
  - timing chain, installing ..... 196
  - torque limiter, installing ..... 192
  - transmission shafts, installing ..... 187
  - valve clearance, adjusting ..... 201
  - valve cover, installing ..... 202
  - water pump cover, installing ..... 195
- Engine disassembly**
- alternator cover, removing ..... 148
  - camshaft, removing ..... 149
  - clutch discs, removing ..... 153
  - clutch push rod, removing ..... 146
  - crankshaft, removing ..... 159
  - cylinder head, removing ..... 149
  - engine oil, draining ..... 145
  - engine, positioning at ignition top dead center ..... 148
  - force pump, removing ..... 157
  - freewheel gear, removing ..... 157
  - ignition pulse generator, removing ..... 151
  - kickstarter idler gear, removing ..... 155
  - kickstarter, removing ..... 147
  - left section of the engine case, removing ..... 157
  - locking lever, removing ..... 156
  - oil pump gear wheel, removing ..... 156
  - outer clutch hub, removing ..... 154
  - piston, removing ..... 150
  - preparations ..... 145
  - primary gear nut, removing ..... 154
  - primary gear, removing ..... 157
  - rotor, removing ..... 150
  - shift drum locating unit, removing ..... 156
  - shift drum, removing ..... 158
  - shift forks, removing ..... 159
  - shift rails, removing ..... 158
  - shift shaft, removing ..... 155
  - spark plug, removing ..... 147
  - starter idler gear, removing ..... 155
  - starter motor, removing ..... 147
  - suction pump, removing ..... 151
  - timing chain guide rail, removing ..... 150
  - timing chain securing guide, removing ..... 151
  - timing chain tensioner, removing ..... 149
  - timing chain tensioning rail, removing ..... 151
  - timing chain, removing ..... 151
  - valve cover, removing ..... 147
  - water pump cover, removing ..... 152
- Engine guard**
- installing ..... 63
  - removing ..... 63
- Engine number** ..... 10
- Engine oil**
- adding ..... 213

- changing ..... 211
- Engine oil level**
  - checking ..... 210
- Engine oil pressure**
  - checking ..... 213
- Engine sprocket**
  - checking ..... 113
- F**
- Figures** ..... 8
- Filler cap**
  - closing ..... 93
  - opening ..... 93
- Foot brake lever**
  - basic position, adjusting ..... 127
  - free travel, checking ..... 127
- Fork legs**
  - assembling ..... 29, 51
  - bleeding ..... 15
  - cartridge, assembling ..... 28, 50
  - cartridge, disassembling ..... 24, 44
  - checking ..... 26, 47
  - compression damping fitting, assembling ..... 27
  - compression damping fitting, disassembling ..... 26
  - disassembling ..... 21, 41
  - dust boots, cleaning ..... 16
  - fork service, performing ..... 21, 40
  - hydrostop unit, assembling ..... 48
  - hydrostop unit, disassembling ..... 46
  - installing ..... 18
  - piston rod, assembling ..... 49
  - piston rod, disassembling ..... 45
  - removing ..... 18
  - seal ring retainer, assembling ..... 48
  - seal ring retainer, disassembling ..... 46
  - spring preload, adjusting ..... 15
  - spring, removing ..... 43
- Fork protector**
  - installing ..... 20
  - loosening ..... 17
  - positioning ..... 17
  - removing ..... 20
- Fork service, performing** ..... 21, 40
- Frame**
  - checking ..... 63
- Front fender**
  - installing ..... 103
  - removing ..... 103
- Front wheel**
  - installing ..... 108
  - removing ..... 108
- Fuel filter**
  - changing ..... 98
- Fuel pressure**
  - checking ..... 101
- Fuel pump**
  - changing ..... 100

- Fuel screen**
  - changing ..... 97
- Fuel tank**
  - installing ..... 95
  - removing ..... 94
- Fuse**
  - individual power consumers, changing ..... 116
  - main fuse, installing ..... 116
  - main fuse, removing ..... 116
- H**
- Hand brake lever**
  - basic position, adjusting ..... 122
  - free travel, adjusting ..... 122
  - free travel, checking ..... 122
- Handlebar position**
  - adjusting ..... 59
- Headlight**
  - headlight range, adjusting ..... 131
- Headlight mask with headlight**
  - installing ..... 104
  - removing ..... 103
- Headlight setting**
  - checking ..... 131
- Heim joint**
  - changing ..... 85
- Hydrostop unit**
  - fork legs, assembling ..... 48
  - fork legs, disassembling ..... 46
- I**
- Idle speed**
  - adjusting ..... 218
- Ignition coil**
  - secondary winding, checking ..... 215
- Initialization run**
  - executing ..... 219
- K**
- Key number** ..... 9
- L**
- Lower triple clamp**
  - installing ..... 34, 37, 56
  - removing ..... 34, 36, 55
- M**
- Main fuse**
  - installing ..... 116
  - removing ..... 116
- Main silencer**
  - changing glass fiber yarn filling ..... 88
  - installing ..... 88
  - removing ..... 88
- Manifold**
  - installing ..... 87
  - removing ..... 87
- Motorcycle**
  - cleaning ..... 229
  - raising with lift stand ..... 11

removing from lift stand .....	11
<b>D</b>	
Oil circuit .....	210
Oil filter	
changing .....	211
Oil pressure regulator valve	
installing .....	163
removing .....	162
spring length, checking .....	162
Oil screens	
cleaning .....	211
Operating substances .....	8
<b>P</b>	
Piston rod	
fork legs, assembling .....	49
fork legs, disassembling .....	45
Play in throttle cable	
checking .....	60
Preparing for use	
after storage .....	231
<b>R</b>	
Rear sprocket	
checking .....	113
Rear wheel	
installing .....	110
removing .....	109
Rebound damping	
fork, adjusting .....	13
shock absorber, adjusting .....	65
Riding sag	
adjusting .....	67
<b>S</b>	
Seal ring retainer	
fork legs, assembling .....	48
fork legs, disassembling .....	46
Seat	
mounting .....	94
removing .....	93
Service schedule .....	232-233
Servicing the shock absorber .....	68
Shock absorber	
damper, assembling .....	79
damper, bleeding and filling .....	81
damper, checking .....	73
damper, disassembling .....	69
damper, filling with nitrogen .....	83
heim joint, installing .....	75
heim joint, removing .....	75
installing .....	68
pilot bushing, replacing .....	73
piston rod, assembling .....	77
piston rod, disassembling .....	71
rebound adjuster, assembling .....	76
rebound adjuster, disassembling .....	74
removing .....	67
riding sag, checking .....	66

seal ring retainer, assembling .....	77
seal ring retainer, disassembling .....	72
shock absorber, servicing .....	68
spring preload, adjusting .....	66
spring, installing .....	84
spring, removing .....	69
static sag, checking .....	65
Spare parts .....	8
Spark plug connector	
checking .....	215
Speedometer	
additional functions, activating .....	133
clock, setting .....	133
kilometers or miles, setting .....	132
setting .....	133
speedometer overview .....	132
wheel circumference, setting .....	134
Spoke tension	
checking .....	107
Spring	
fork legs, removing .....	43
Starter motor	
checking .....	217
Starting .....	11-12
Stator	
installing .....	216
removing .....	216
Steering head bearing	
greasing .....	33, 55
Steering head bearing play	
adjusting .....	39-40, 58
checking .....	39, 57
Storage .....	231
<b>T</b>	
Technical data	
capacities .....	224
chassis .....	224
chassis tightening torques .....	227
electrical system .....	225
engine .....	221
engine - tolerance, wear limits .....	221
engine tightening torques .....	222
fork .....	225
shock absorber .....	226
tires .....	225
Throttle cable play	
adjusting .....	61
Throttle cable routing	
checking .....	60
Throttle position sensor	
basic settings, adjusting .....	219
circuit A - checking the basic settings .....	218
Tire air pressure	
checking .....	106
Tire condition	
checking .....	106

Type label .....	9
<b>W</b>	
Warranty .....	8
<b>Winter operation</b>	
checks and maintenance steps .....	230
<b>Wiring diagram</b> .....	234-309
page 1 of 6 .....	298
page 1 of 8 .....	234, 250, 266, 282
page 2 of 6 .....	300
page 2 of 8 .....	236, 252, 268, 284
page 3 of 6 .....	302
page 3 of 8 .....	238, 254, 270, 286
page 4 of 6 .....	304
page 4 of 8 .....	240, 256, 272, 288
page 5 of 6 .....	306
page 5 of 8 .....	242, 258, 274, 290
page 6 of 6 .....	308
page 6 of 8 .....	244, 260, 276, 292
page 7 of 8 .....	246, 262, 278, 294
page 8 of 8 .....	248, 264, 280, 296
<b>Work rules</b> .....	7



3206209en

05/2015



**KTM**