

450 SX-F EU
450 SX-F USA
450 XC-F USA

Art. no. 3206208en



KTM

Read this repair manual carefully and thoroughly before beginning work.

The vehicle will only be able to meet the demands placed on it if the specified service work is performed regularly and properly.

This repair manual was written to correspond to the latest state of this series. We reserve the right to make changes in the interest of technical advancement without at the same time updating this repair manual. We shall not provide a description of general workshop methods. Likewise, safety rules that apply in a workshop are not specified here. It is assumed that the repair work will be performed by a fully trained mechanic.

All specifications are non-binding. KTM Sportmotorcycle AG specifically reserves the right to modify or delete technical specifications, prices, colors, forms, materials, services, designs, equipment, etc., without prior notice and without specifying reasons, to adapt these to local conditions, as well as to stop production of a particular model without prior notice. KTM accepts no liability for delivery options, deviations from illustrations and descriptions, misprints, and other errors. The models portrayed partly contain special equipment that does not belong to the regular scope of supply.

© 2014 KTM-Sportmotorcycle AG, Mattighofen Austria

All rights reserved

Reproduction, even in part, as well as copying of all kinds, is permitted only with the express written permission of the copyright owner.



ISO 9001(12 100 6061)

According to the international quality management standard ISO 9001, KTM uses quality assurance processes that lead to the maximum possible quality of the products.

Issued by: TÜV Management Service

REG.NR. 12 100 6061

KTM-Sportmotorcycle AG
5230 Mattighofen, Austria

TABLE OF CONTENTS

1	MEANS OF REPRESENTATION.....	6	6.10.7	Disassembling the hydrostop unit.....	44
1.1	Symbols used.....	6	6.10.8	Disassembling the seal ring retainer.....	45
1.2	Formats used.....	6	6.10.9	Checking the fork legs.....	45
2	SAFETY ADVICE.....	7	6.10.10	Assembling the seal ring retainer.....	46
2.1	Repair Manual.....	7	6.10.11	Assembling the hydrostop unit.....	46
2.2	Safety advice.....	7	6.10.12	Assembling the piston rod.....	47
2.3	Degrees of risk and symbols.....	7	6.10.13	Assembling the cartridge.....	48
2.4	Work rules.....	7	6.10.14	Assembling the fork legs.....	49
3	IMPORTANT NOTES.....	8	6.11	XC-F.....	53
3.1	Guarantee, warranty.....	8	6.11.1	Performing a fork service.....	53
3.2	Operating and auxiliary substances.....	8	6.11.2	Performing a fork service.....	53
3.3	Spare parts, accessories.....	8	6.11.3	Disassembling the fork legs.....	54
3.4	Figures.....	8	6.11.4	Removing the spring.....	56
4	SERIAL NUMBERS.....	9	6.11.5	Disassembling the cartridge.....	57
4.1	Chassis number.....	9	6.11.6	Disassembling the piston rod.....	58
4.2	Type label.....	9	6.11.7	Disassembling the hydrostop unit.....	59
4.3	Engine number.....	9	6.11.8	Disassembling the seal ring retainer.....	59
4.4	Fork part number.....	9	6.11.9	Checking the fork legs.....	60
4.5	Shock absorber part number.....	9	6.11.10	Assembling the seal ring retainer.....	61
5	MOTORCYCLE.....	10	6.11.11	Assembling the hydrostop unit.....	61
5.1	Raising the motorcycle with the lift stand.....	10	6.11.12	Assembling the piston rod.....	62
5.2	Removing the motorcycle from the lift stand.....	10	6.11.13	Assembling the cartridge.....	63
5.3	Starting.....	10	6.11.14	Assembling the fork legs.....	64
5.4	Starting the motorcycle for a check.....	11	6.12	Greasing the steering head bearing.....	68
6	FORK, TRIPLE CLAMP.....	12	6.13	Removing the lower triple clamp.....	68
6.1	Adjusting the compression damping of the fork.....	12	6.14	Installing the lower triple clamp.....	69
6.2	Adjusting the rebound damping of the fork.....	12	6.15	Checking the steering head bearing play.....	71
6.3	Bleeding the fork legs.....	13	6.16	Adjusting the play of the steering head bearing.....	71
6.4	Cleaning the dust boots of the fork legs.....	14	7	HANDLEBAR, CONTROLS.....	73
6.5	Removing the fork legs.....	14	7.1	Handlebar position.....	73
6.6	Installing the fork legs.....	15	7.2	Adjusting the handlebar position.....	73
6.7	Removing the fork protector.....	15	7.3	Adjusting the basic position of the clutch lever.....	73
6.8	Installing the fork protector.....	16	7.4	Checking the throttle cable routing.....	74
6.9	SX-F EU.....	16	7.5	Checking the play in the throttle cable.....	74
6.9.1	Conducting major fork service.....	16	7.6	Adjusting the play in the throttle cable.....	75
6.9.2	Conducting minor fork service.....	16	8	SHOCK ABSORBER, SWINGARM.....	76
6.9.3	Disassembling the fork legs.....	17	8.1	Adjusting the high-speed compression damping of the shock absorber.....	76
6.9.4	Disassembling the cartridge.....	19	8.2	Adjusting the low-speed compression damping of the shock absorber.....	76
6.9.5	Disassembling the piston rod.....	21	8.3	Adjusting the rebound damping of the shock absorber.....	77
6.9.6	Disassembling the screw cap with the membrane holder.....	23	8.4	Measuring rear wheel sag unloaded.....	78
6.9.7	Disassembling the screw sleeve.....	24	8.5	Checking the static sag of the shock absorber....	78
6.9.8	Checking the fork legs.....	24	8.6	Checking the riding sag of the shock absorber....	78
6.9.9	Checking the fork legs - during a minor fork service.....	26	8.7	Adjusting the spring preload of the shock absorber.....	79
6.9.10	Changing the pilot bushing.....	27	8.8	Adjusting the riding sag.....	79
6.9.11	Assembling the screw sleeve.....	28	8.9	Removing the shock absorber.....	80
6.9.12	Assembling the screw cap with the membrane holder.....	28	8.10	Installing the shock absorber.....	81
6.9.13	Assembling the piston rod.....	29	8.11	Checking the shock absorber linkage.....	82
6.9.14	Assembling the cartridge.....	30	8.12	Servicing the shock absorber.....	84
6.9.15	Assembling the fork legs.....	32	8.13	Removing the spring.....	84
6.9.16	Bleeding and filling the cartridge.....	35	8.14	Disassembling the damper.....	85
6.9.17	Filling the cartridge with nitrogen.....	37	8.15	Disassembling the piston rod.....	86
6.10	SX-F USA.....	37	8.16	Disassembling the seal ring retainer.....	87
6.10.1	Performing a fork service.....	37	8.17	Changing the pilot bushing.....	88
6.10.2	Disassembling the fork legs.....	38	8.18	Checking the damper.....	88
6.10.3	Removing the spring.....	40	8.19	Removing the heim joint.....	89
6.10.4	Disassembling the cartridge.....	41	8.20	Installing the heim joint.....	90
6.10.5	Disassembling the cartridge.....	42			
6.10.6	Disassembling the piston rod.....	43			

8.21	Assembling the seal ring retainer.....	91	14	WIRING HARNESS, BATTERY.....	128
8.22	Assembling the piston rod.....	91	14.1	Changing the main fuse.....	128
8.23	Assembling the damper.....	93	14.2	Removing the battery.....	129
8.24	Bleeding and filling the damper.....	95	14.3	Installing the battery.....	129
8.25	Filling the damper with nitrogen.....	97	14.4	Charging the battery.....	129
8.26	Installing the spring.....	98	14.5	Checking the charging voltage.....	130
9	EXHAUST.....	100	14.6	Checking the quiescent current.....	131
9.1	Removing the manifold.....	100	14.7	Checking the capacitor.....	131
9.2	Installing the manifold.....	100	14.8	Checking the starter relay.....	132
9.3	Removing the main silencer.....	101	15	BRAKE SYSTEM.....	134
9.4	Installing the main silencer.....	101	15.1	Checking the front brake linings.....	134
9.5	Changing the glass fiber yarn filling of the main silencer.....	101	15.2	Changing the front brake linings.....	134
10	AIR FILTER.....	103	15.3	Checking the free travel of the hand brake lever.....	135
10.1	Removing the air filter box lid.....	103	15.4	Adjusting the basic position of the hand brake lever.....	136
10.2	Installing the air filter box lid.....	103	15.5	Checking the brake fluid level of the front brake.....	136
10.3	Removing the air filter.....	103	15.6	Adding front brake fluid.....	137
10.4	Installing the air filter.....	104	15.7	Changing the front brake fluid.....	138
10.5	Cleaning the air filter and air filter box.....	104	15.8	Checking the rear brake linings.....	139
10.6	Sealing the air filter box.....	105	15.9	Changing the rear brake linings.....	139
10.7	Securing the air filter box lid.....	105	15.10	Checking the free travel of foot brake lever.....	141
11	FUEL TANK, SEAT, TRIM.....	106	15.11	Adjusting the basic position of the foot brake lever.....	141
11.1	Opening the filler cap.....	106	15.12	Checking the rear brake fluid level.....	141
11.2	Closing the filler cap.....	106	15.13	Adding rear brake fluid.....	142
11.3	Removing the seat.....	107	15.14	Changing the rear brake fluid.....	143
11.4	Mounting the seat.....	107	16	ENGINE.....	145
11.5	Removing the fuel tank.....	107	16.1	Removing the engine.....	145
11.6	Installing the fuel tank.....	108	16.2	Installing the engine.....	149
11.7	Checking the fuel pressure.....	109	16.3	Engine disassembly.....	155
11.8	Changing the fuel pump.....	110	16.3.1	Preparations.....	155
11.9	Changing the fuel filter.....	112	16.3.2	Draining the engine oil.....	155
11.10	Changing the fuel screen.....	114	16.3.3	Removing the clutch push rod.....	156
12	MASK, FENDER.....	116	16.3.4	Removing the oil filter.....	156
12.1	Removing the front fender.....	116	16.3.5	Removing the starter motor.....	156
12.2	Installing the front fender.....	116	16.3.6	Removing the spark plug.....	156
12.3	Removing the start number plate.....	116	16.3.7	Removing the valve cover.....	157
12.4	Installing the start number plate.....	117	16.3.8	Removing the alternator cover.....	157
13	WHEELS.....	118	16.3.9	Positioning the engine at ignition top dead center.....	157
13.1	Checking the tire air pressure.....	118	16.3.10	Removing the timing chain tensloner.....	158
13.2	Checking the tire condition.....	118	16.3.11	Removing the camshaft.....	158
13.3	Checking the brake discs.....	118	16.3.12	Removing the cylinder head.....	159
13.4	Checking the spoke tension.....	119	16.3.13	Removing the piston.....	159
13.5	Front wheel.....	119	16.3.14	Removing the rotor.....	159
13.5.1	Removing the front wheel.....	119	16.3.15	Removing the timing chain.....	160
13.5.2	Installing the front wheel.....	120	16.3.16	Removing the ignition pulse generator.....	160
13.5.3	Removing the brake disc of the front brake.....	121	16.3.17	Removing the suction pump.....	161
13.5.4	Installing the brake disc of the front brake.....	121	16.3.18	Removing the water pump cover.....	161
13.6	Rear wheel.....	121	16.3.19	Removing the clutch cover.....	161
13.6.1	Removing the rear wheel.....	121	16.3.20	Removing the clutch discs.....	162
13.6.2	Installing the rear wheel.....	122	16.3.21	Removing the outer clutch hub.....	163
13.6.3	Removing the brake disc of the rear brake.....	123	16.3.22	Removing the torque limiter.....	164
13.6.4	Installing the brake disc of the rear brake.....	123	16.3.23	Removing the starter idler gear.....	164
13.6.5	Checking the chain tension.....	123	16.3.24	Removing the shift shaft.....	164
13.6.6	Adjusting the chain tension.....	124	16.3.25	Removing the shift drum locating unit.....	164
13.6.7	Checking the chain, rear sprocket, engine sprocket, and chain guide.....	124	16.3.26	Removing the locking lever.....	164
13.6.8	Checking for chain dirt accumulation.....	126	16.3.27	Removing the force pump.....	165
13.6.9	Cleaning the chain.....	126	16.3.28	Removing the primary gear.....	166
			16.3.29	Removing the freewheel gear.....	166

16.3.30	Removing the left engine case section	166	16.5.4	Installing the shift drum	203
16.3.31	Removing the shift rails	167	16.5.5	Installing the shift rails	204
16.3.32	Removing the shift drum	167	16.5.6	Installing the left engine case	204
16.3.33	Removing the shift forks	168	16.5.7	Installing the freewheel gear	206
16.3.34	Removing the transmission shafts	168	16.5.8	Installing the primary gear	206
16.3.35	Removing the crankshaft	169	16.5.9	Installing the force pump	206
16.4	Work on individual parts	170	16.5.10	Installing the locking lever	207
16.4.1	Work on the right section of the engine case	170	16.5.11	Installing the shift drum locating unit	207
16.4.2	Work on the left section of the engine case	171	16.5.12	Installing the shift shaft	207
16.4.3	Removing the oil pressure regulator valve	172	16.5.13	Installing the starter idler gear	208
16.4.4	Checking spring length of oil pressure regulator valve	172	16.5.14	Installing the torque limiter	208
16.4.5	Installing the oil pressure regulator valve	173	16.5.15	Installing the outer clutch hub	208
16.4.6	Changing the crankshaft seal ring in the clutch cover	173	16.5.16	Installing the clutch discs	209
16.4.7	Removing the water pump	173	16.5.17	Installing the clutch cover	210
16.4.8	Installing the water pump	174	16.5.18	Installing the water pump cover	211
16.4.9	Removing the timing chain sprocket	175	16.5.19	Installing the suction pump	211
16.4.10	Installing the timing chain sprocket	175	16.5.20	Installing the ignition pulse generator	212
16.4.11	Changing the connecting rod, conrod bearing, and crank pin	175	16.5.21	Installing the timing chain	212
16.4.12	Checking crankshaft run-out at bearing pin	177	16.5.22	Installing the rotor	213
16.4.13	Cylinder - Nikasil® coating	177	16.5.23	Installing the piston	213
16.4.14	Checking/measuring the cylinder	177	16.5.24	Installing the cylinder head	215
16.4.15	Checking/measuring the piston	178	16.5.25	Installing the camshaft	216
16.4.16	Checking the piston ring end gap	178	16.5.26	Installing the timing chain tensioner	216
16.4.17	Measuring the piston/cylinder mounting clearance	179	16.5.27	Checking the valve clearance	217
16.4.18	Checking the oil pumps	179	16.5.28	Adjusting the valve clearance	217
16.4.19	Disassembling the autodecompressor	179	16.5.29	Installing the alternator cover	217
16.4.20	Assembling the autodecompressor	180	16.5.30	Installing the valve cover	218
16.4.21	Checking camshaft	181	16.5.31	Installing the spark plug	218
16.4.22	Checking the timing assembly	181	16.5.32	Installing the starter motor	218
16.4.23	Removing the rocker arm	182	16.5.33	Installing the oil filter	218
16.4.24	Removing the valves	182	16.5.34	Installing the clutch push rod	219
16.4.25	Changing camshaft bearing	183	16.5.35	Installing the oil screens	219
16.4.26	Checking the valves	183	16.5.36	Removing the engine from the engine assembly stand	220
16.4.27	Checking valve springs	184	17	CLUTCH	221
16.4.28	Checking valve spring seat	184	17.1	Checking/correcting the fluid level of the hydraulic clutch	221
16.4.29	Checking the cylinder head	184	17.2	Changing the hydraulic clutch fluid	221
16.4.30	Checking the rocker arm shafts	185	18	WATER PUMP, COOLING SYSTEM	222
16.4.31	Installing the valves	185	18.1	Cooling system	222
16.4.32	Installing the rocker arm	186	18.2	Checking the antifreeze and coolant level	222
16.4.33	Checking the clutch	187	18.3	Checking the coolant level	222
16.4.34	Checking the shift mechanism	188	18.4	Draining the coolant	223
16.4.35	Preassembling the shift shaft	190	18.5	Refilling coolant	224
16.4.36	Disassembling the main shaft	191	19	LUBRICATION SYSTEM	225
16.4.37	Disassembling the countershaft	192	19.1	Oil circuit	225
16.4.38	Checking the transmission	193	19.2	Checking the engine oil level	225
16.4.39	Assembling the main shaft	196	19.3	Changing the engine oil and oil filter, cleaning the oil screens	226
16.4.40	Assembling the countershaft	197	19.4	Adding engine oil	228
16.4.41	Checking the starter drive	200	19.5	Checking the engine oil pressure	228
16.4.42	Checking the freewheel	200	20	IGNITION SYSTEM	230
16.4.43	Removing the freewheel	201	20.1	Ignition coil - checking the secondary winding	230
16.4.44	Installing the freewheel	201	20.2	Checking the spark plug connector	230
16.5	Engine assembly	202	20.3	Alternator - checking stator winding	230
16.5.1	Installing the crankshaft	202	20.4	Removing the stator	231
16.5.2	Installing the transmission shafts	202	20.5	Installing the stator	231
16.5.3	Installing the shift forks	203	21	ELECTRIC STARTER	232
			21.1	Checking the starter motor	232
			22	THROTTLE VALVE BODY	233
			22.1	Adjusting the idle speed	233

TABLE OF CONTENTS

22.2	Executing the initialization run.....	233
23	TECHNICAL DATA.....	234
23.1	Engine.....	234
23.2	Engine tolerance, wear limits.....	234
23.3	Engine tightening torques.....	235
23.4	Capacities.....	236
23.4.1	Engine oil.....	236
23.4.2	Coolant.....	236
23.4.3	Fuel.....	236
23.5	Chassis.....	236
23.6	Electrical system.....	237
23.7	Tires.....	237
23.8	Fork.....	238
23.8.1	SX-F EU.....	238
23.8.2	SX-F USA.....	238
23.8.3	XC-F.....	238
23.9	Shock absorber.....	239
23.9.1	SX-F EU.....	239
23.9.2	SX-F USA.....	239
23.9.3	XC-F.....	240
23.10	Chassis tightening torques.....	241
24	CLEANING/PROTECTIVE TREATMENT.....	242
24.1	Cleaning the motorcycle.....	242
25	STORAGE.....	243
25.1	Storage.....	243
25.2	Preparing for use after storage.....	243
26	SERVICE SCHEDULE.....	244
26.1	Service schedule.....	244
26.2	Service work (as additional order).....	245
27	WIRING DIAGRAM.....	246
27.1	Page 1 of 3 (SX-F EU, SX-F USA).....	246
27.2	Page 2 of 3 (SX-F EU, SX-F USA).....	248
27.3	Page 3 of 3 (SX-F EU, SX-F USA).....	250
27.4	Page 1 of 3 (XC-F).....	252
27.5	Page 2 of 3 (XC-F).....	254
27.6	Page 3 of 3 (XC-F).....	256
28	SUBSTANCES.....	258
29	AUXILIARY SUBSTANCES.....	260
30	SPECIAL TOOLS.....	262
31	STANDARDS.....	277
	INDEX.....	278

1.1 Symbols used

The meaning of specific symbols is described below.



Indicates an expected reaction (e.g. of a work step or a function).



Indicates an unexpected reaction (e.g. of a work step or a function).



Indicates a page reference (more information is provided on the specified page).



Indicates information with more details or tips.



Indicates the result of a testing step.



Denotes a voltage measurement.



Denotes a current measurement.



Denotes a resistance measurement.

1.2 Formats used

The typographical formats used in this document are explained below.

Proprietary name Identifies a proprietary name.

Name® Identifies a protected name.

Brand™ Identifies a trademark.

2.1 Repair Manual

Read this Repair Manual carefully and thoroughly before beginning work. It contains useful information and tips that will help you repair and maintain your vehicle.

This manual assumes that the necessary special KTM tools and KTM workplace and workshop equipment are available.

2.2 Safety advice

A number of safety instructions need to be followed to operate the vehicle safely. Therefore, read this manual carefully. The safety instructions are highlighted in the text and are referred to at the relevant passages.

 **Info**
The vehicle has various information and warning labels at prominent locations. Do not remove information/warning labels. If they are missing, you or others may not recognize dangers and may therefore be injured.

2.3 Degrees of risk and symbols

 **Danger**
Identifies a danger that will immediately and invariably lead to fatal or serious permanent injury if the appropriate measures are not taken.

 **Warning**
Identifies a danger that is likely to lead to fatal or serious injury if the appropriate measures are not taken.

 **Caution**
Identifies a danger that may lead to minor injuries if the appropriate measures are not taken.

Note
Identifies a danger that will lead to considerable machine and material damage if the appropriate measures are not taken.

 **Warning**
Identifies a danger that will lead to environmental damage if the appropriate measures are not taken.

2.4 Work rules

Special tools are necessary for certain tasks. The tools are not contained in the vehicle but can be ordered under the number in parentheses. E.g.: bearing puller (15112017000)

During assembly, non-reusable parts (e.g. self-locking screws and nuts, seals and seal rings, O-rings, pins, lock washers) must be replaced by new parts.

In some instances, a thread locker (e.g. **Loctite**[®]) is required. The manufacturer instructions for use must be followed.

After disassembly, clean the parts that are to be reused and check them for damage and wear. Change damaged or worn parts.

After you complete the repair or service work, check the operating safety of the vehicle.

3.1 Guarantee, warranty

The work prescribed in the service schedule must be carried out by an authorized KTM workshop only and confirmed in the customer's Service & Warranty Booklet and in the **KTM dealer.net**; otherwise, all warranty claims will be void. No warranty claims can be considered for damage resulting from manipulations and/or alterations to the vehicle.

Additional information on the guarantee or warranty and the procedures involved can be found in the Service & Warranty Booklet.

3.2 Operating and auxiliary substances



Warning

Environmental hazard Improper handling of fuel is a danger to the environment.

- Do not allow fuel to get into the ground water, the ground, or the sewage system.

Use the operating and auxiliary substances (such as fuel and lubricants) as specified in the manual.

3.3 Spare parts, accessories

Only use spare parts and accessories approved and/or recommended by KTM. KTM accepts no liability for other products and any resulting damage or loss.

The current **KTM PowerParts** for your vehicle can be found on the KTM website.

International KTM Website: <http://www.ktm.com>

3.4 Figures

The figures contained in the manual may depict special equipment.

In the interest of clarity, some components may be shown disassembled or may not be shown at all. It is not always necessary to disassemble the component to perform the activity in question. Please follow the instructions in the text.

4.1 Chassis number

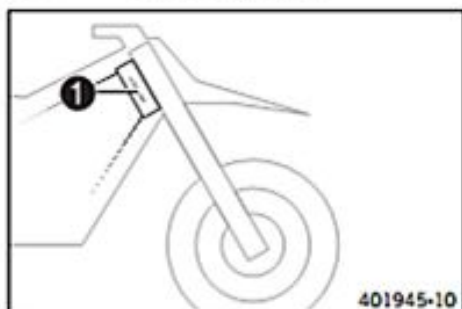

The chassis number ❶ is stamped on the right side of the steering head.

4.2 Type label

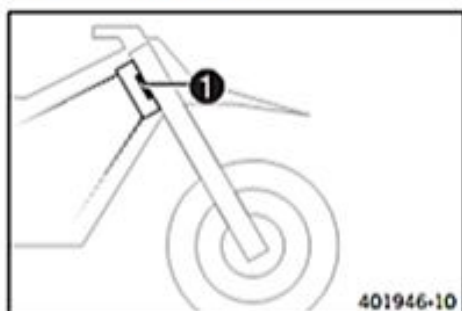

The type label ❶ is fixed to the front of the steering head.

4.3 Engine number

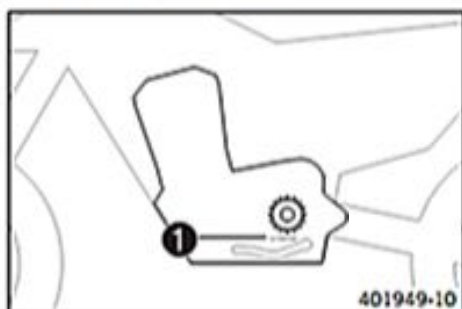

The engine number ❶ is stamped on the left side of the engine under the engine sprocket.

4.4 Fork part number

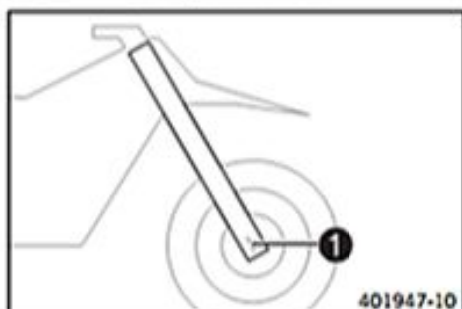

The fork part number ❶ is stamped on the inner side of the axle clamp.

4.5 Shock absorber part number

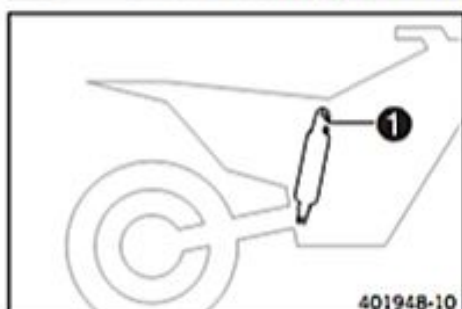

The shock absorber part number ❶ is stamped on the top of the shock absorber above the adjusting ring on the engine side.

5.1 Raising the motorcycle with the lift stand

Note

Danger of damage The parked vehicle may roll away or fall over.

- Always place the vehicle on a firm and even surface.

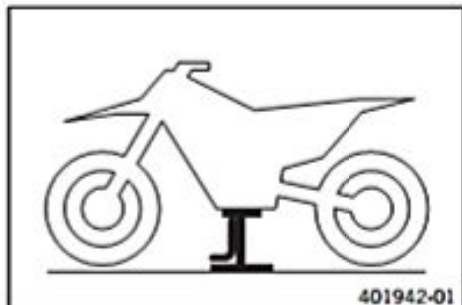

- Raise the motorcycle at the frame underneath the engine.
 - ✓ The wheels must no longer touch the ground.
- Secure the motorcycle against falling over.

Lift stand (54829055000) (☞ p. 264)

5.2 Removing the motorcycle from the lift stand

Note

Danger of damage The parked vehicle may roll away or fall over.

- Always place the vehicle on a firm and even surface.

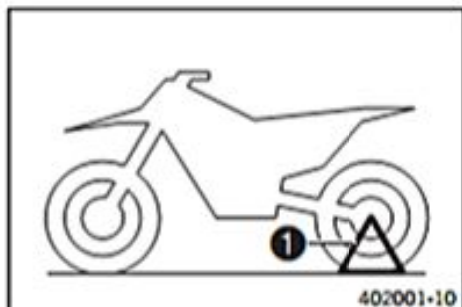

(SX-F EU, SX-F USA)

- Remove the motorcycle from the lift stand.
- Remove the lift stand.
- To park the motorcycle, insert plug-in stand ❶ into the left side of the wheel spindle.



Info

Remove the plug-in stand before riding.

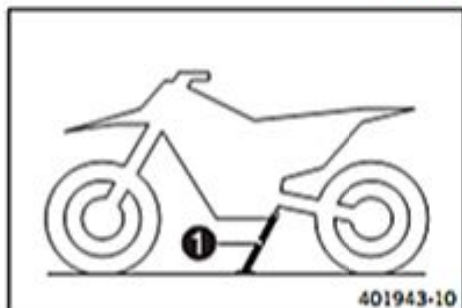

(XC-F)

- Remove the motorcycle from the lift stand.
- Remove the lift stand.
- To park the motorcycle, press side stand ❶ to the ground with your foot and lean the motorcycle on it.



Info

When you are riding, the side stand must be folded up and secured with the rubber band.

5.3 Starting



Danger

Danger of poisoning Exhaust gases are toxic and inhaling them may result in unconsciousness and/or death.

- When running the engine, always make sure there is sufficient ventilation, and do not start or run the engine in an enclosed space without an effective exhaust extraction system.

Note

Engine failure High engine speeds in cold engines have a negative effect on the service life of the engine.

- Always warm up the engine at low engine speeds.

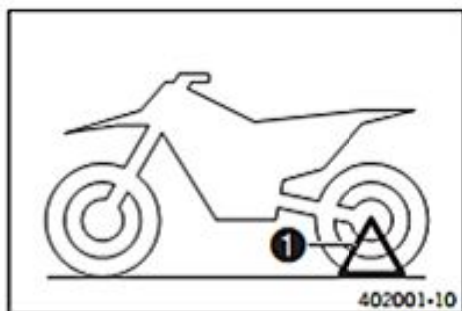

(SX-F EU, SX-F USA)

- Remove plug-in stand ①.

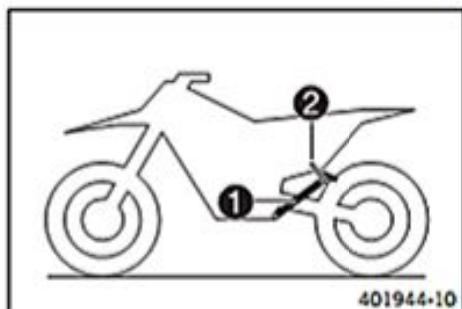

(XC-F)

- Take the motorcycle off of side stand ① and secure the side stand with rubber band ②.
- Shift gear to neutral.

Condition

Ambient temperature: < 20 °C (< 68 °F)

- Pull the cold start button out all the way.

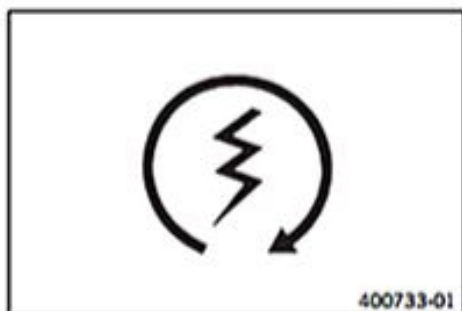

- Press the electric starter button (ⓘ).

i Info

Press the electric starter button for at most 5 seconds. Wait for a least 5 seconds before trying again.

FI warning lamp lights up briefly as a functional control when starting.

5.4 Starting the motorcycle for a check

! Danger

Danger of poisoning Exhaust gases are toxic and inhaling them may result in unconsciousness and/or death.

- When running the engine, always make sure there is sufficient ventilation, and do not start or run the engine in an enclosed space without an effective exhaust extraction system.

i Info

Press the starter for a maximum of 5 seconds. Wait for at least 5 seconds before trying again.



- Shift gear to neutral.
- Press the electric starter button (ⓘ).

i Info

Do not open the throttle.

6.1 Adjusting the compression damping of the fork

- i** Info
The hydraulic compression damping determines the fork suspension behavior.



(SX-F EU)

- Turn adjusting screws ① clockwise all the way.

- i** Info
Adjusting screws ① are located at the top end of the fork legs. Make the same adjustment on both fork legs.

- Turn counterclockwise by the number of clicks corresponding to the fork type.

Guideline

Compression damping	
Comfort	14 clicks
Standard	12 clicks
Sport	10 clicks

- i** Info
Turn clockwise to increase damping; turn counterclockwise to reduce damping.



(SX-F USA, XC-F)

- Turn the white adjusting screw ② all the way clockwise.

- i** Info
Adjusting screw ② is located at the upper end of the left fork leg. The compression damping is located in the left fork leg (white adjusting screw). The rebound damping is located in the right fork leg (red adjusting screw).

- Turn counterclockwise by the number of clicks corresponding to the fork type.

Guideline

Compression damping (SX-F USA)	
Comfort	17 clicks
Standard	15 clicks
Sport	13 clicks
Compression damping (XC-F)	
Comfort	17 clicks
Standard	15 clicks
Sport	13 clicks

- i** Info
Turn clockwise to increase damping; turn counterclockwise to reduce damping.

6.2 Adjusting the rebound damping of the fork

- i** Info
The hydraulic rebound damping determines the fork suspension behavior.

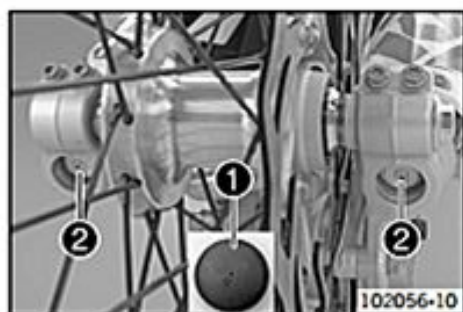

(SX-F EU)

- Remove protection caps ①.
- Turn adjusting screws ② clockwise all the way.

**Info**

Adjusting screws ② are located at the bottom end of the fork legs. Make the same adjustment on both fork legs.

- Turn counterclockwise by the number of clicks corresponding to the fork type.

Guideline

Rebound damping	
Comfort	14 clicks
Standard	12 clicks
Sport	10 clicks

**Info**

Turn clockwise to increase damping; turn counterclockwise to reduce damping.

- Mount protection caps ①.



(SX-F USA, XC-F)

- Turn the red adjusting screw ③ all the way clockwise.

**Info**

Adjusting screw ③ is located at the upper end of the right fork leg. The rebound damping is located in the right fork leg (red adjusting screw). The compression damping is located in the left fork leg (white adjusting screw).

- Turn counterclockwise by the number of clicks corresponding to the fork type.

Guideline

Rebound damping (SX-F USA)	
Comfort	17 clicks
Standard	15 clicks
Sport	13 clicks

Rebound damping (XC-F)	
Comfort	17 clicks
Standard	15 clicks
Sport	13 clicks

**Info**

Turn clockwise to increase damping; turn counterclockwise to reduce damping.

6.3 Bleeding the fork legs

**Preparatory work**

- Raise the motorcycle with the lift stand. (☛ p. 10)

Main work

- Release bleeder screws ①.
 - ✓ Any excess pressure escapes from the interior of the fork.
- Tighten the bleeder screws.

Finishing work

- Remove the motorcycle from the lift stand. (☛ p. 10)

6.4 Cleaning the dust boots of the fork legs



Preparatory work

- Raise the motorcycle with the lift stand. (☞ p. 10)
- Remove the fork protector. (☞ p. 15)

Main work

- Push dust boots ① of both fork legs downward.



Info

The dust boots remove dust and coarse dirt particles from the inside fork tubes. Over time, dirt can penetrate behind the dust boots. If this dirt is not removed, the oil seals behind can start to leak.



Warning

Danger of accidents Reduced braking efficiency due to oil or grease on the brake discs.

- Always keep the brake discs free of oil and grease, and clean them with brake cleaner when necessary.

- Clean and oil the dust boots and inner fork tube of both fork legs.

Universal oil spray (☞ p. 261)

- Press the dust boots back into their normal position.
- Remove excess oil.

Finishing work

- Install the fork protector. (☞ p. 16)
- Remove the motorcycle from the lift stand. (☞ p. 10)

6.5 Removing the fork legs

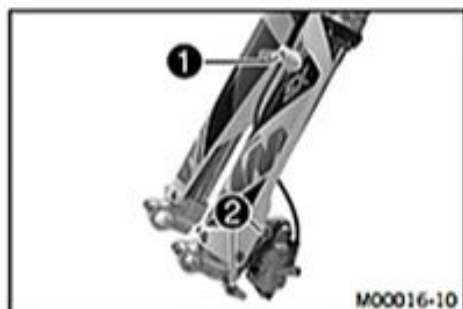

Preparatory work

- Raise the motorcycle with the lift stand. (☞ p. 10)
- Remove the front wheel. (☞ p. 119)

Main work

- Remove screws ① and take off the clamp.
- Remove screws ② and take off the brake caliper.
- Allow the brake caliper and brake line to hang tension-free to the side.



Info

Do not pull the hand brake lever if the front wheel has been removed.

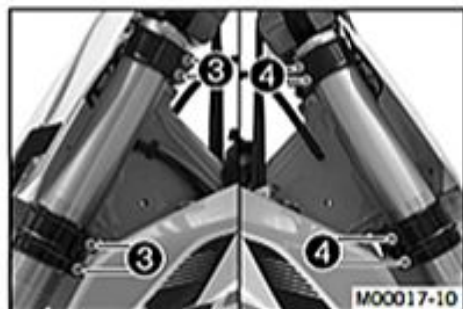

- Loosen screws ③. Take out the left fork leg.
- Unscrew screws ④. Take out the right fork leg.

6.6 Installing the fork legs

Main work
(SX-F EU)

- Position the fork legs.
- ✓ Position bleeder screws 1 toward the front.



Info

Grooves are milled into the side of the upper end of the fork legs. The second milled groove (from the top) must be flush with the top edge of the upper triple clamp.



(SX-F USA, XC-F)

- Position the fork legs.
- ✓ Position bleeder screws 1 toward the front.



Info

The rebound damping is located in the right fork leg (red adjusting screw). The compression damping is located in the left fork leg (white adjusting screw).

Grooves are milled into the side of the upper end of the fork legs. The second milled groove (from the top) must be flush with the top edge of the upper triple clamp.

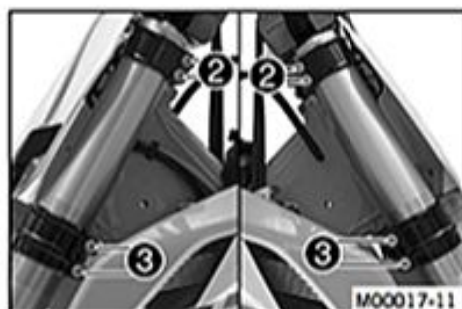

- Tighten screws 2.

Guideline

Screw, top triple clamp	M8	17 Nm (12.5 lbf ft)
-------------------------	----	------------------------

- Tighten screws 3.

Guideline

Screw, bottom triple clamp	M8	12 Nm (8.9 lbf ft)
----------------------------	----	--------------------

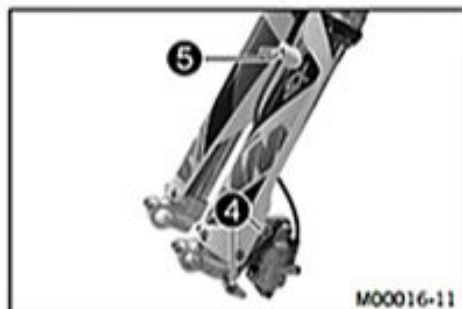

- Position the brake caliper. Mount and tighten screws 4.

Guideline

Screw, front brake caliper	M8	25 Nm (18.4 lbf ft)	Loctite® 243™
----------------------------	----	------------------------	---------------

- Position the brake line and clamp. Mount and tighten screws 5.

Finishing work

- Install the front wheel. (☛ p. 120)

6.7 Removing the fork protector

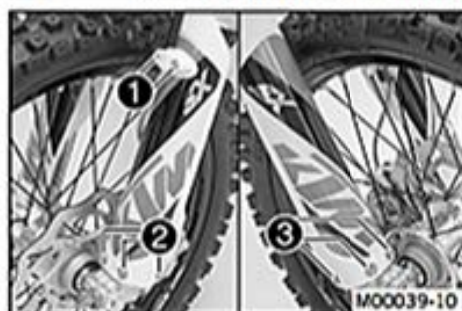

- Remove screws 1. Take off the clamp.
- Remove screws 2. Take off the left fork protector.
- Remove screws 3. Take off the right fork protector.

6.8 Installing the fork protector

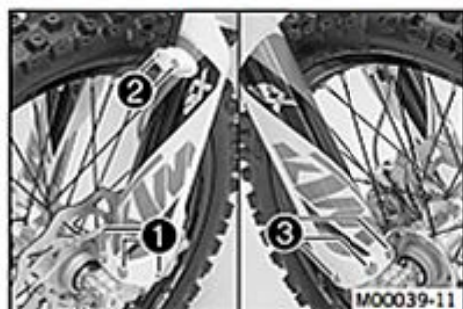

- Position the fork protection on the left fork leg. Mount and tighten screws **1**.

Guideline

Remaining screws, chassis	M6	10 Nm (7.4 lbf ft)
---------------------------	----	--------------------

- Position the brake line and clamp. Mount and tighten screws **2**.
- Position the fork protector on the right fork leg. Mount and tighten screws **3**.

Guideline

Remaining screws, chassis	M6	10 Nm (7.4 lbf ft)
---------------------------	----	--------------------

6.9 SX-F EU

6.9.1 Conducting major fork service

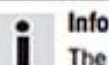

Info

The steps are identical for both fork legs.

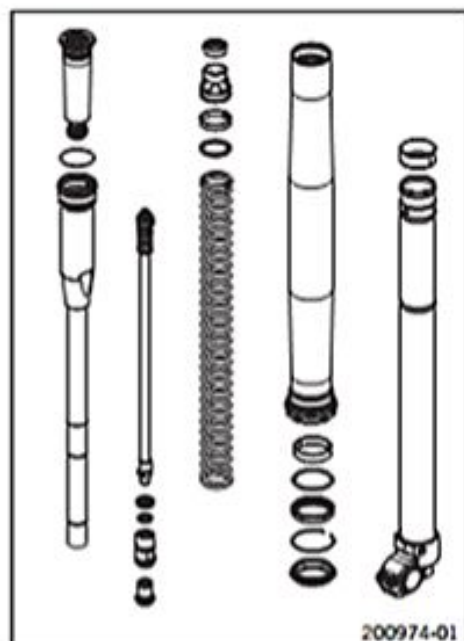

Condition

The fork legs are disassembled.

- Disassemble the fork legs. (☛ p. 17)
- Disassemble the cartridge. (☛ p. 19)
- Disassemble the piston rod. (☛ p. 21)
- Disassemble the screw cap with the membrane holder. (☛ p. 23)
- Disassemble the screw sleeve. (☛ p. 24)
- Check the fork legs. (☛ p. 24)
- Change the pilot bushing. (☛ p. 27)
- Assemble the screw sleeve. (☛ p. 28)
- Assemble the screw cap with the membrane holder. (☛ p. 28)
- Assemble the piston rod. (☛ p. 29)
- Assemble the cartridge. (☛ p. 30)
- Assemble the fork legs. (☛ p. 32)

6.9.2 Conducting minor fork service



Info

The steps are identical for both fork legs.

Condition

The fork legs are disassembled.

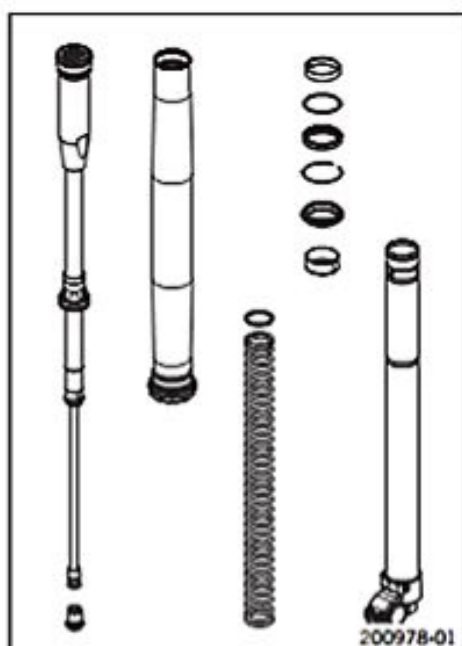

- Disassemble the fork legs. (☛ p. 17)
- Check the fork legs - during a minor fork service. (☛ p. 26)
- Assemble the fork legs. (☛ p. 32)

6.9.3 Disassembling the fork legs

i Info
The steps are identical for both fork legs.

Condition

The fork legs are disassembled.



- Remove protection cap **A**.
- Note down the present state of rebound damping **1** and compression damping **2**.
- Fully open the adjusters of the rebound and compression damping.



- Clamp the fork leg in the area of the lower triple clamp.

Clamping stand (T1403S) (☛ p. 275)

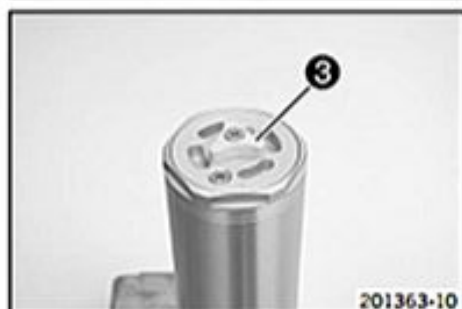

- Remove the screw. Remove adjuster **3** of the compression damping.



- Loosen cartridge **4**.

Ring wrench (T14017) (☞ p. 273)



Info

The cartridge cannot be taken off yet.



- Unclamp the fork leg.
- Push the outer tube down. Drain the fork oil.

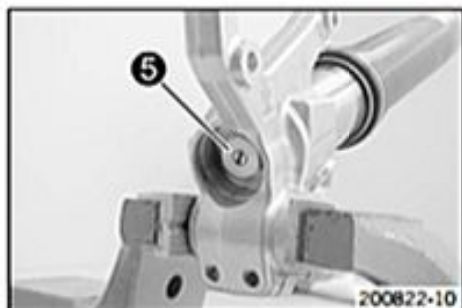

- Clamp the fork leg with the axle clamp.
- Guideline

Use soft jaws.

- Loosen rebound adjustment **5**.



Info

Do not use an impact wrench.
Place a fluid collector beneath it, as usually some oil will drain out.
The rebound adjustment cannot be removed yet.

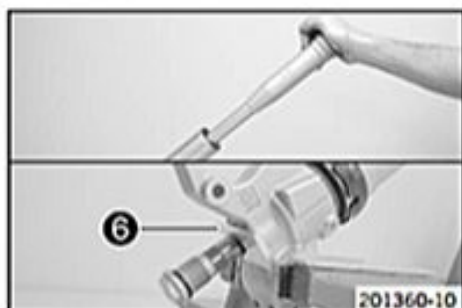

- Press the cartridge against the spring and mount special tool **6** on the piston rod.

Support tool (T14020) (☞ p. 273)

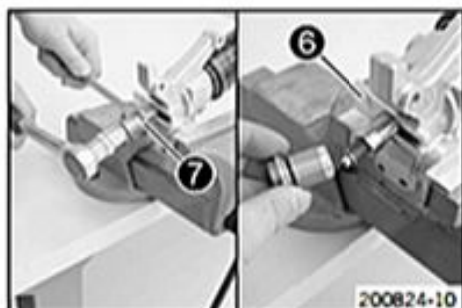

- Hold nut **7** and remove the rebound adjuster.
- Press the cartridge against the spring and remove special tool **6**.
- Remove the cartridge from the fork leg.
- Unclamp the fork leg.

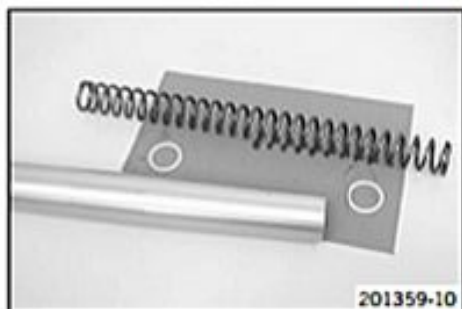

- Remove the preload spacers and spring.

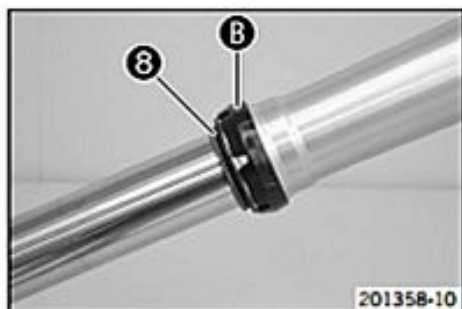

- Remove dust boot **8**.
- Remove fork protection ring **6**.

i Info

The fork protection ring does not necessarily need to be removed for repair work.

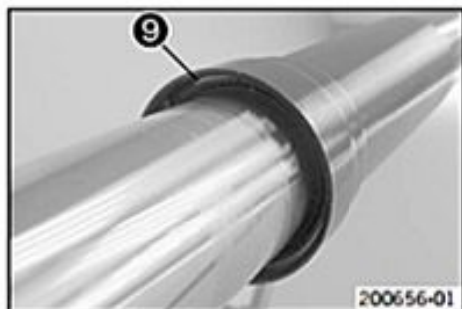

- Remove lock ring **9**.

i Info

The lock ring has a ground end against which a screwdriver can be positioned.

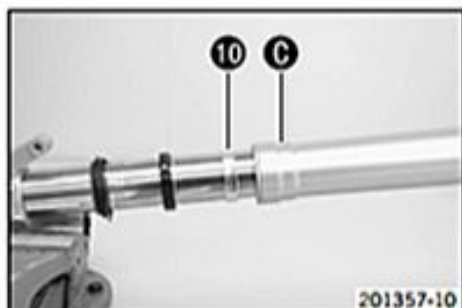

- Warm the outer tube in area **B** of the lower sliding bushing.

Guideline

50 °C (122 °F)

- Pull the outer tube forcefully off of the inner tube.

i Info

The lower sliding bushing **10** must be pulled out of its bearing seat.



- Remove upper sliding bushing **11**.

i Info

Without using a tool, carefully pull the stack apart by hand.



- Take off the lower sliding bushing **10**.
- Take off support ring **12**.
- Take off seal ring **13**.
- Take off lock ring **9**.
- Take off dust boot **8**.
- Unclamp the fork leg.

6.9.4 Disassembling the cartridge

i Info

The steps are identical for both fork legs.

Preparatory work

- Disassemble the fork legs. (☛ p. 17)



Main work

- Remove adjusting tube ① and nut ②.



- Clamp the cartridge into a vise.



Info

Use soft jaws.

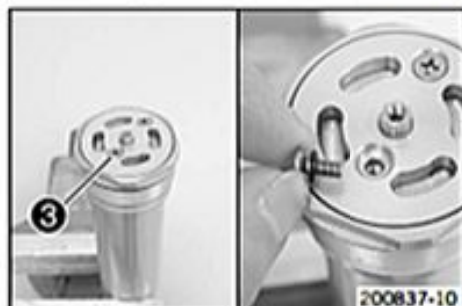

- Remove filling screw ③.



- Pierce the membrane with the needle of the special tool.

Nitrogen charging tool (T14019) (☞ p. 273)

- ✓ The pressurized nitrogen is bled off.



- Loosen and remove screw cap ④ with the membrane holder.

Pin wrench (T103) (☞ p. 270)

- Unclamp the cartridge.



- Empty the cartridge.



- Reclamp the cartridge upside down.

Guideline

Use soft jaws.

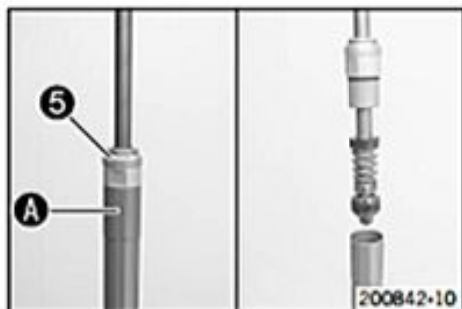

- Heat the cartridge in area **A** of pilot bushing **5**.

Guideline

100 °C (212 °F)

- Loosen the screw sleeve and remove the piston rod.

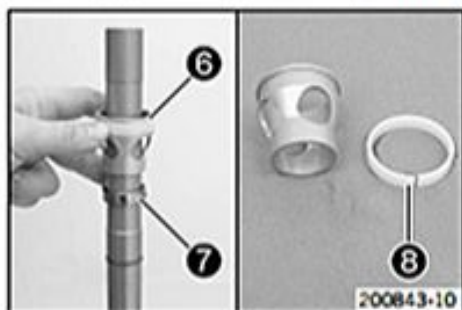

- Remove spring guide **6** and ring **7**.
- Remove guide ring **8**.

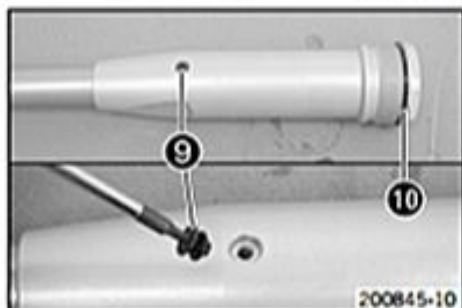

- Remove filling screw **9** and O-ring **10**.

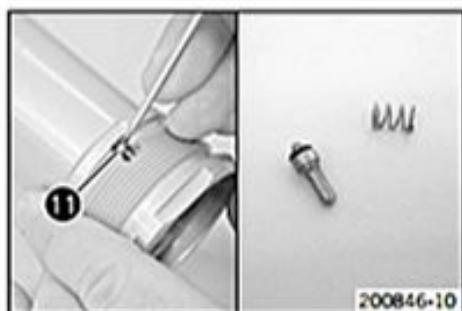

- Press check valve **11** against the spring and remove it.

6.9.5 Disassembling the piston rod



Info

The steps are identical for both fork legs.

Preparatory work

- Disassemble the fork legs. (☛ p. 17)
- Disassemble the cartridge. (☛ p. 19)



Main work

- Remove screw sleeve ① and washer ② from the piston rod.

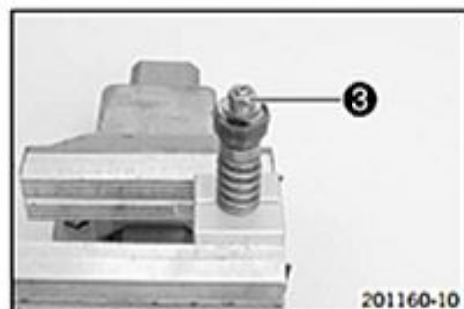

- Degrease the piston rod.
- Clamp the piston rod with the special tool as far up as possible.

Clamping stand (T14016S) (☞ p. 273)

- Remove nut ③.

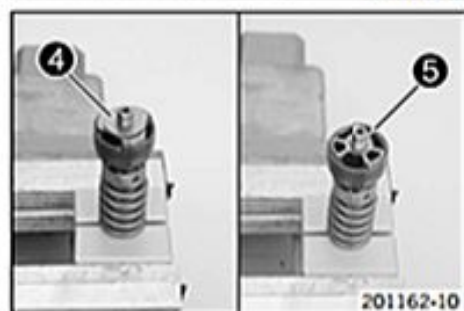

- Remove rebound shim stack ④.
- Remove rebound piston ⑤.



- Remove the piston ring from the piston.

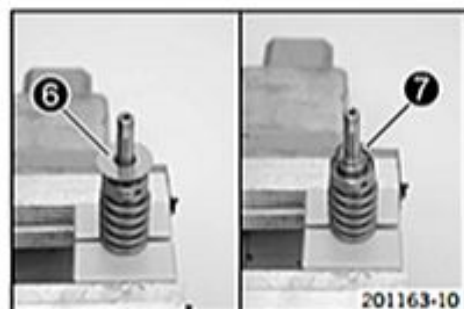

- Remove compression shim stack ⑥.
- Remove spring ⑦.

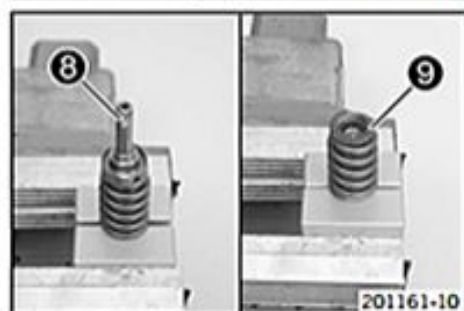

- Remove tap rebound ⑧.
- Remove spring ⑨ with the sleeve.

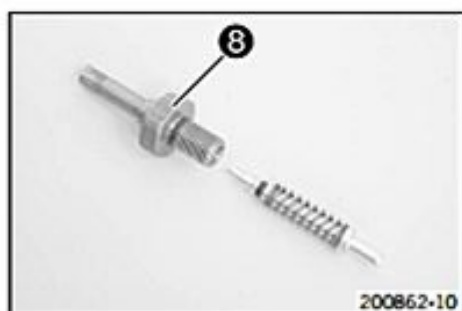

- Remove the valve with the spring from tap rebound ⑧.
- Remove the O-rings.

6.9.6 Disassembling the screw cap with the membrane holder

i Info
The steps are identical for both fork legs.

Preparatory work

- Disassemble the fork legs. (☛ p. 17)
- Disassemble the cartridge. (☛ p. 19)

Main work

- Clamp the screw cap with the membrane holder and the special tool into a vise.

Guideline

Use soft jaws.

Pin wrench (T103) (☛ p. 270)

i Info
Only tighten the vise lightly.

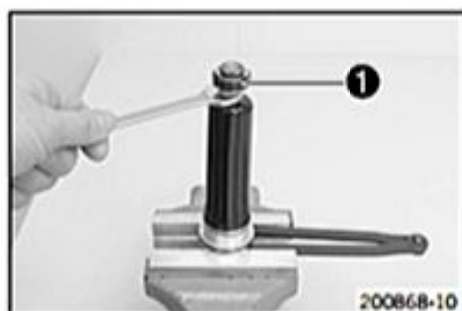

- Remove compression holder ①.
- Remove membrane ②. Unclamp the special tool.
- Remove O-ring ③.

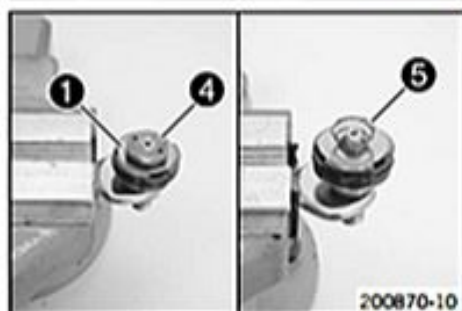
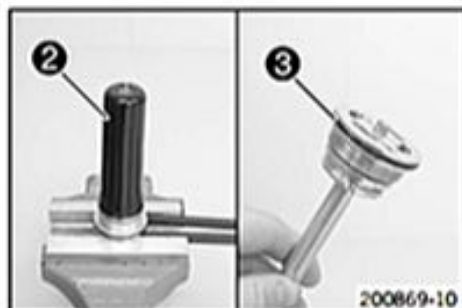

- Clamp the open end wrench in a vise. Position compression holder ①.
- Remove nut ④.
- Remove spring ⑤.

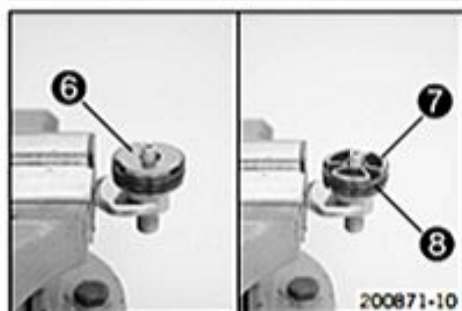

- Remove rebound washer ⑥.
- Remove compression piston ⑦. Remove O-ring ⑧.

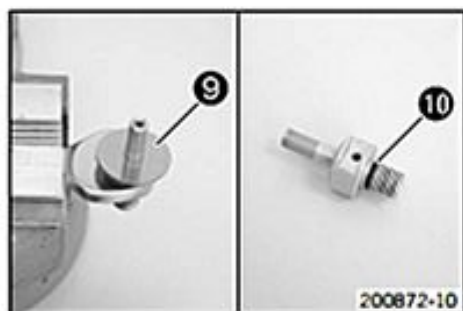

- Remove compression shim stack ⑨.
- Remove O-ring ⑩.

6.9.7 Disassembling the screw sleeve

Info

The steps are identical for both fork legs.

Preparatory work

- Disassemble the fork legs. (☛ p. 17)
- Disassemble the cartridge. (☛ p. 19)
- Disassemble the piston rod. (☛ p. 21)

Main work

- Remove O-ring ①.
- Remove lock ring ②. Remove ring ③.

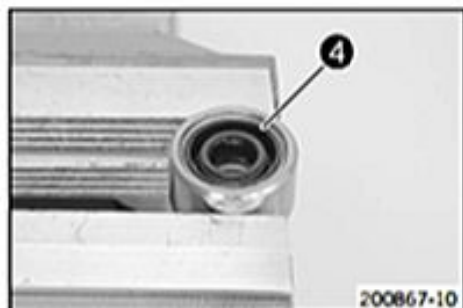

- Screw the special tool onto the screw sleeve.

Threaded bushing (T14023) (☛ p. 274)

- ✓ The special tool must have an overhang to protect the thread.

Overhang	1 mm (0.04 in)
----------	----------------

- Pry out seal ring ④, being sure only to brace the lever against the special tool.

6.9.8 Checking the fork legs

Condition

The fork legs have been disassembled.

- Check the inner tube and axle clamp for damage.
 - If there is damage:
 - Change the inner tube.

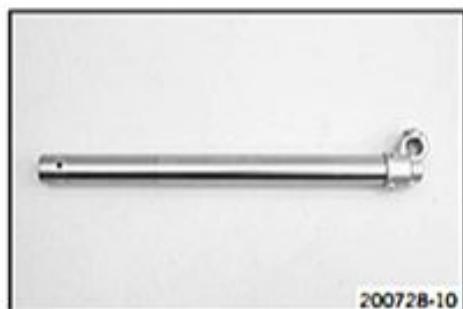

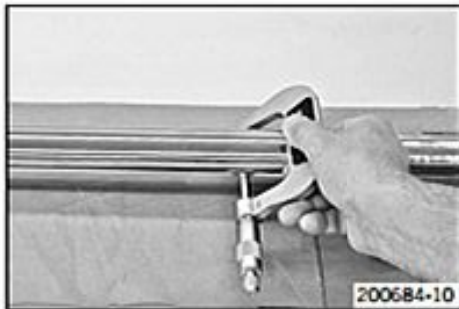

- Measure the outside diameter of the inner tube at several locations.

Outside diameter of the inner tube	47.975... 48.005 mm (1.88878... 1.88996 in)
------------------------------------	---

- If the measured value is less than the specified value:
 - Change the inner tube.

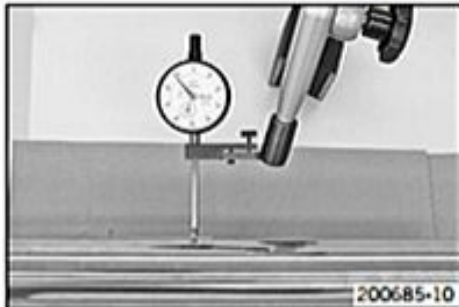

- Measure the run-out of the inner tube.

Inner tube run-out	≤ 0.20 mm (≤ 0.0079 in)
--------------------	-------------------------

- If the measured value is greater than the specified value:
 - Change the inner tube.

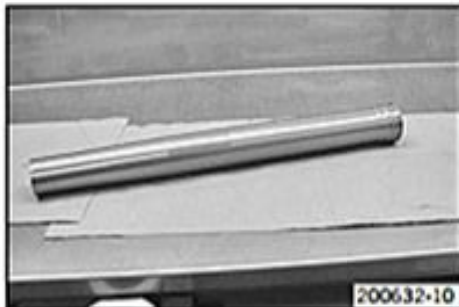

- Measure the inside diameter of the outer tube at several locations.

Inside diameter of the outer tube	≤ 49.20 mm (≤ 1.937 in)
-----------------------------------	-------------------------

- If the measured value is greater than the specified value:
 - Change the outer tube.
- Check the outer tube for damage.
 - If there is damage:
 - Change the outer tube.



- Check the surface of the sliding bushing.

- If the bronze-colored layer **A** under the sliding layer **B** is visible or the surface is rough:
 - Replace the sliding bushing.

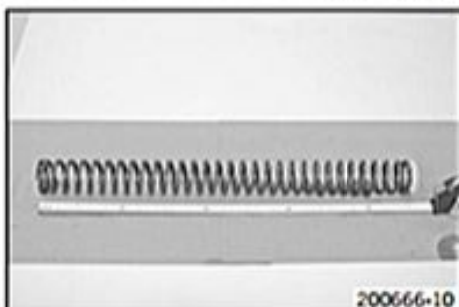

- Check the spring length.

Guideline

Spring length with preload spacer(s)	490 mm (19.29 in)
--------------------------------------	-------------------

- If the measured value is greater than the specified value:
 - Reduce the thickness of the preload spacers.
- If the measured value is less than the specified value:
 - Increase the thickness of the preload spacers.

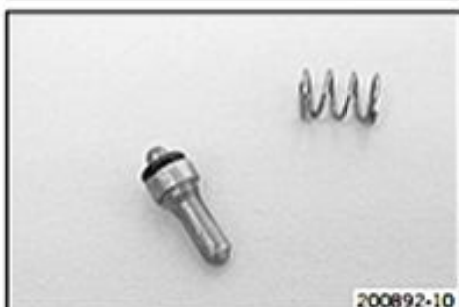

- Check the check valve spring length.

Guideline

Spring length of the check valve	≥ 5.8 mm (≥ 0.228 in)
----------------------------------	-----------------------

- If the measured value is less than the specified value:
 - Change the spring.



- Check the piston rod for damage.
 - If there is damage:
 - Replace the piston rod.
- Measure the outside diameter of the piston rod at several locations.

Outside diameter of the piston rod	$\geq 11.965 \text{ mm } (\geq 0.47106 \text{ in})$
------------------------------------	---

- If the measured value is less than the specified value:
 - Replace the piston rod.
- Measure the run-out of the piston rod.

Run-out of the piston rod	$\leq 0.40 \text{ mm } (\leq 0.0157 \text{ in})$
---------------------------	--

- If the measured value is greater than the specified value:
 - Replace the piston rod.

6.9.9 Checking the fork legs - during a minor fork service

Condition

The fork legs have been disassembled.

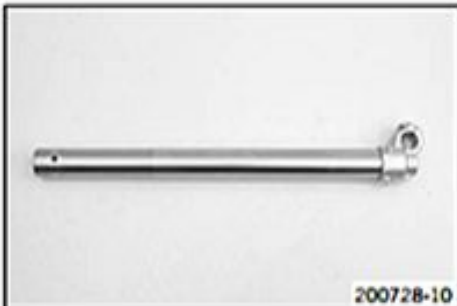

- Check the inner tube and axle clamp for damage.
 - If there is damage:
 - Change the inner tube.

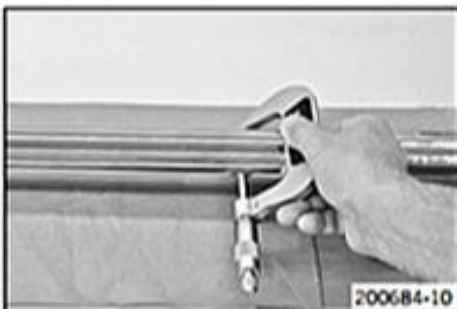

- Measure the outside diameter of the inner tube at several locations.

Outside diameter of the inner tube	$47.975... 48.005 \text{ mm } (1.88878... 1.88996 \text{ in})$
------------------------------------	--

- If the measured value is less than the specified value:
 - Change the inner tube.

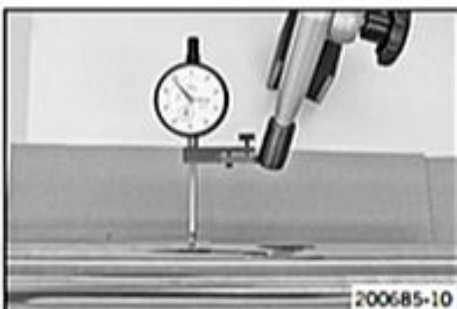

- Measure the run-out of the inner tube.

Inner tube run-out	$\leq 0.20 \text{ mm } (\leq 0.0079 \text{ in})$
--------------------	--

- If the measured value is greater than the specified value:
 - Change the inner tube.

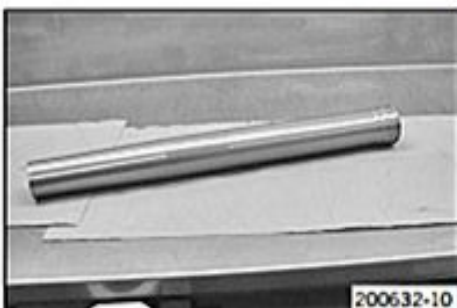

- Measure the inside diameter of the outer tube at several locations.

Inside diameter of the outer tube	$\leq 49.20 \text{ mm } (\leq 1.937 \text{ in})$
-----------------------------------	--

- If the measured value is greater than the specified value:
 - Change the outer tube.
- Check the outer tube for damage.
 - If there is damage:
 - Change the outer tube.



- Check the surface of the sliding bushing.
 - If the bronze-colored layer **A** under the sliding layer **B** is visible or the surface is rough:
 - Replace the sliding bushing.

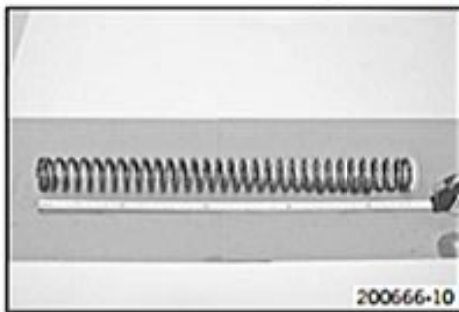

- Check the spring length.

Guideline

Spring length with preload spacer(s)	490 mm (19.29 in)
--------------------------------------	-------------------

- If the measured value is greater than the specified value:
 - Reduce the thickness of the preload spacers.
- If the measured value is less than the specified value:
 - Increase the thickness of the preload spacers.

6.9.10 Changing the pilot bushing

Preparatory work

- Disassemble the fork legs. (☞ p. 17)
- Disassemble the cartridge. (☞ p. 19)
- Disassemble the piston rod. (☞ p. 21)
- Disassemble the screw sleeve. (☞ p. 24)



Main work

- Press the pilot bushing out of screw sleeve **1** using the special tool.

Mounting tool (T14022) (☞ p. 274)

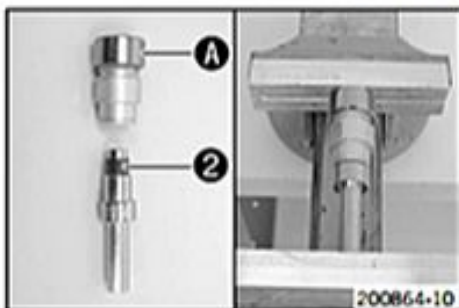

- Slide the new pilot bushing **2** onto the special tool.

Mounting tool (T14022) (☞ p. 274)

- Ensure that special tool **A** is mounted and that there is an overhang to protect the thread.

Guideline

Overhang	1 mm (0.04 in)
----------	----------------

Threaded bushing (T14023) (☞ p. 274)

- Position the pilot bushing in the screw sleeve with the special tool and press it in all the way.

Mounting tool (T14022) (☞ p. 274)

- Lubricate the special tool.

Fork oil (SAE 4) (48601166S1) (☞ p. 258)
--

Calibrating unit (T14021) (☞ p. 273)

- Press the special tool through the new pilot bushing a number of times.

Calibrating unit (T14021) (☞ p. 273)

✓ The pilot bushing is calibrated.



Finishing work

- Assemble the screw sleeve. (☞ p. 28)

6.9.11 Assembling the screw sleeve

i Info
The steps are identical for both fork legs.



- Mount and lubricate O-ring ①.
- | |
|-----------------------------|
| Lubricant (T158) (☛ p. 260) |
|-----------------------------|
- Mount ring ②.
 - Mount lock ring ③.

i Info
The seal ring is mounted when the piston rod is assembled.

6.9.12 Assembling the screw cap with the membrane holder

i Info
The steps are identical for both fork legs.

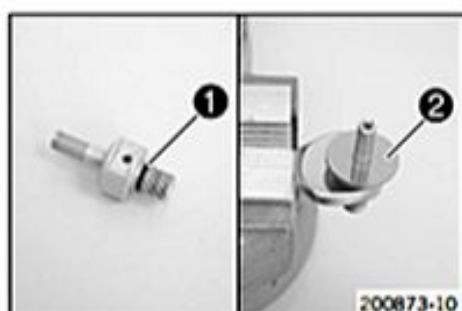

- Preparatory work**
- Check the fork legs. (☛ p. 24)

Main work

- Lubricate and mount O-ring ①.
- | |
|-----------------------------|
| Lubricant (T158) (☛ p. 260) |
|-----------------------------|
- Clamp the open end wrench in a vise. Position compression holder.
 - Mount the compression shim stack ② with the smaller shims facing downward.

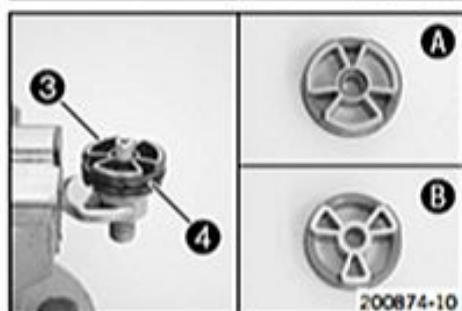

- Grind compression piston ③ on both sides on a surfacing plate using 1200 grit sandpaper.
- Clean the compression piston.
- Mount and grease O-ring ④.

Lubricant (T158) (☛ p. 260)

- Mount the compression piston.

Guideline

View ①	Compression piston from above
View ②	Compression piston from below

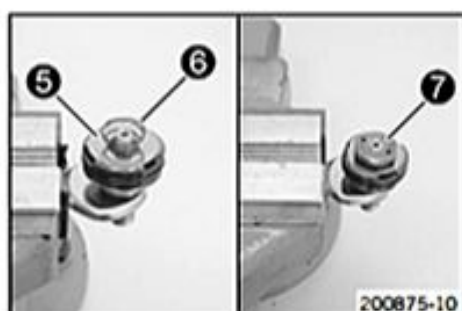

- Mount rebound damping washer ⑤.
- Mount spring ⑥ with the tighter coil at the bottom.
- Mount and tighten new nut ⑦ with the collar facing downward.

Guideline

Nut, compression piston	M6x0.5	3 Nm (2.2 lbf ft)
-------------------------	--------	-------------------

- ✓ The collar centers the rebound washer and the spring.
- Check the freedom of movement of the rebound washer against the spring.
- Secure the nut by locking.



- Mount and grease O-ring 8.

Lubricant (T158) (☛ p. 260)

- Clamp the screw cap with the membrane holder and the special tool into a vise.

Pin wrench (T103) (☛ p. 270)

Info

Only tighten the vise lightly.

- Mount membrane 9.
- Mount and tighten compression holder 10.

Guideline

Compression holder	M9x1	8 Nm (5.9 lbf ft)	Loctite® 241
--------------------	------	----------------------	--------------

- Unclamp the special tool.

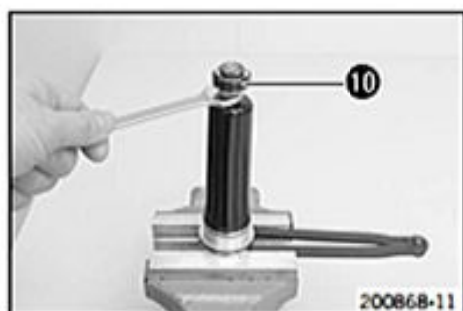

6.9.13 Assembling the piston rod

Info

The steps are identical for both fork legs.



- Mount and grease the O-rings of tap rebound 1 and the valve.

Lubricant (T158) (☛ p. 260)

- Position the valve with the spring in the tap rebound.

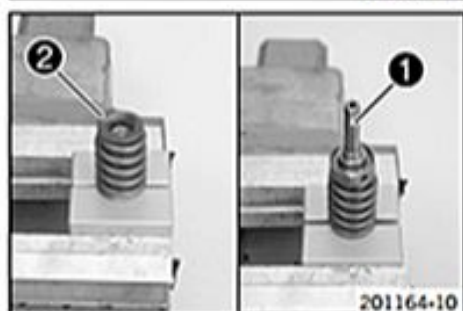

- Degrease the piston rod.
- Clamp the piston rod with the special tool.

Clamping stand (T14016S) (☛ p. 273)

- Mount spring 2 with the sleeve.
- Mount and tighten tap rebound 1.

Guideline

Tap rebound	M9x1	18 Nm (13.3 lbf ft)	Loctite® 2701™
-------------	------	------------------------	----------------

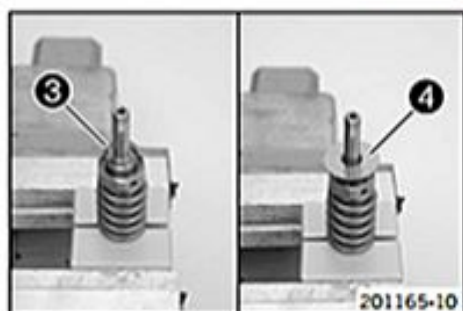

- Mount spring 3.
- Mount compression shim stack 4 with the smaller washer facing downward.

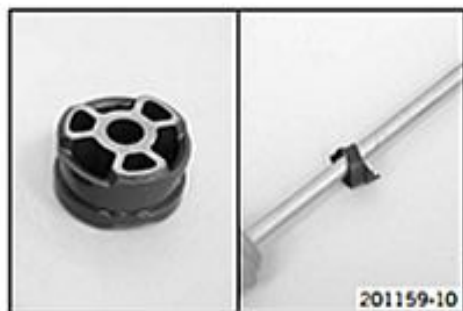

- Grind the rebound piston on both sides on a surface plate with 1200 grit sandpaper.
- Clean the rebound piston.
- Wrap the piston ring around the shaft of a screwdriver before mounting.
- Mount the piston ring.
- Lubricate the piston ring.

Fork oil (SAE 4) (48601166S1) (☛ p. 258)

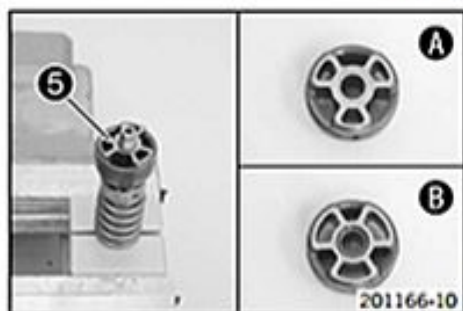

- Mount rebound piston ⑤.

Guideline

View A	Rebound piston from above
View B	Rebound piston from below

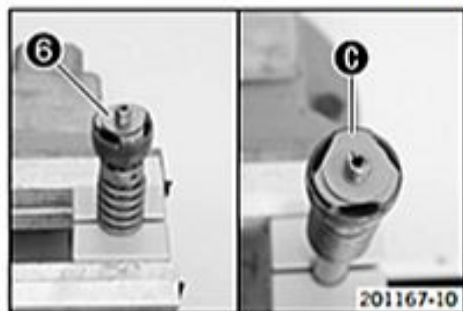

- Mount rebound shim stack ⑥.

i Info

Align triangular plates ⑥ exactly with the openings of the rebound piston.

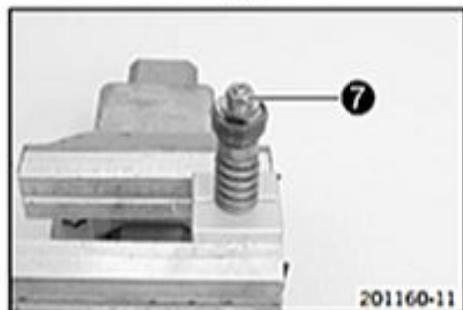

- Mount and tighten new nut ⑦ with the collar facing downward.

Guideline

Rebound nut	M6x0.5	5 Nm (3.7 lbf ft)
-------------	--------	-------------------

i Info

Do not twist the triangular plates!

- Secure the nut by locking.
- Take out the piston rod.

6.9.14 Assembling the cartridge



Info

The steps are identical for both fork legs.

Preparatory work

- Check the fork legs. (☛ p. 24)
- Assemble the screw cap with the membrane holder. (☛ p. 28)
- Assemble the piston rod. (☛ p. 29)

Main work

- Lubricate and mount O-ring ①.

Lubricant (T158) (☛ p. 260)

- Mount the spring and O-ring on check valve ②.

Lubricant (T158) (☛ p. 260)

- Mount the check valve with the special tool.

Tweezers (T14033) (☛ p. 274)

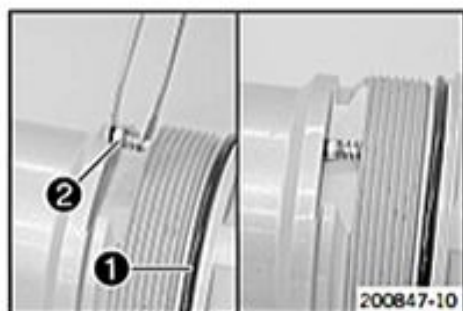



- Mount guide ring ③.
- Mount spring guide ④ and ring ⑤.

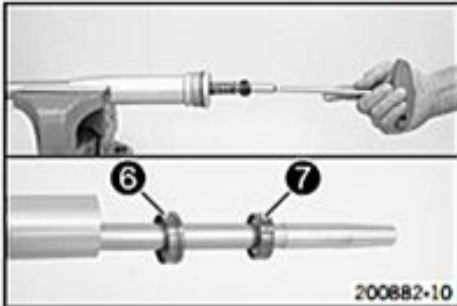

- Clamp the cartridge in a bench vise.

Guideline

Use soft jaws.

- Push the piston rod into the cartridge.



Info

Check that the piston ring is correctly seated.

- Slide washer ⑥ onto the piston rod with the open side forward.
- Place the special tool onto the piston rod.

Mounting sleeve (T14029) (☛ p. 274)

- Grease seal ring ⑦ and slide onto the piston rod with the open side forward. Remove the special tool.

Lubricant (T511) (☛ p. 260)



- Slide screw sleeve ⑧ onto the piston rod.
- Press the seal ring flush into the screw sleeve.
- Grease the O-ring of the screw sleeve.

Lubricant (T158) (☛ p. 260)

- Tighten the screw sleeve.

Guideline

Screw sleeve on the cartridge	M24x1	40 Nm (29.5 lbf ft)	Loctite® 241
-------------------------------	-------	------------------------	--------------

M24x1

40 Nm
(29.5 lbf ft)

Loctite® 241

- Mount filling screw ⑨ with the O-ring.

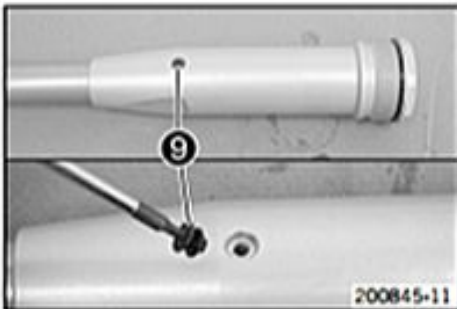

- Clamp the cartridge vertically and fill with fork oil to the lower edge ① of the upper part of the cartridge.

Fork oil (SAE 4) (48601166S1) (☛ p. 258)

✓ The piston rod is fully extended.

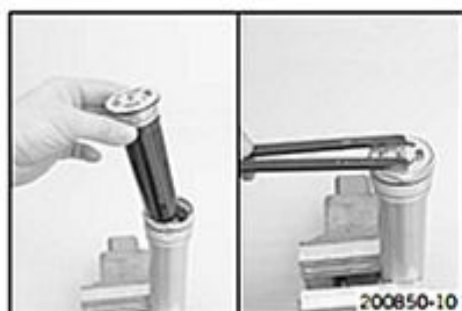

- Mount the screw cap with the membrane holder and tighten with the special tool.

Guideline

Screw cap on the cartridge	M41x1	30 Nm (22.1 lbf ft)
----------------------------	-------	------------------------

Pin wrench (T103) (☛ p. 270)

- Bleed and fill the cartridge. (☛ p. 35)
- Fill the cartridge with nitrogen. (☛ p. 37)



- Mount adjusting tube 10.
- Screw nut 11 all the way on with the collar facing forward.

i Info

The nut must be screwed tightly against the stop. Do not use a tool.

6.9.15 Assembling the fork legs



Info

The steps are identical for both fork legs.

Preparatory work

- Check the fork legs. (☛ p. 24)
- Assemble the screw cap with the membrane holder. (☛ p. 28)
- Assemble the piston rod. (☛ p. 29)
- Assemble the cartridge. (☛ p. 30)

Main work

- Clamp in the inner tube with the axle clamp.

Guideline

Use soft jaws.

- Mount the special tool.

Protecting sleeve (T1401) (☛ p. 272)

- Lubricate and slide on dust boot 1.

Lubricant (T511) (☛ p. 260)

i Info

Always change the dust boot, seal ring, lock ring and support ring. Mount the sealing lip with the spring expander facing downward.

- Slide on lock ring 2.
- Lubricate and slide on seal ring 3.

Lubricant (T511) (☛ p. 260)

✓ Mount with the sealing lip facing downward the open side facing upward.

- Slide on support ring 4.
- Remove the special tool.





- Roughen, clean and lubricate the edges of the sliding bushings using 600 grit sandpaper.

Fork oil (SAE 4) (48601166S1) (☞ p. 258)



- Slide on lower sliding bushing ⑤.
- Mount upper sliding bushing ⑥.

i Info

Gently pull them apart without using a tool.



- Slide on the outer tube.
- Warm up the outer tube in area A of the lower sliding bushing.

Guideline

50 °C (122 °F)

- Hold the lower sliding bushing with the longer shoulder of the special tool.
- Mounting tool (T14040S) (☞ p. 275)
- Press the outer tube all the way in.



- Position the support ring.
- Hold the seal ring with the shorter shoulder of the special tool.

Mounting tool (T14040S) (☞ p. 275)

- Press the outer tube all the way in.

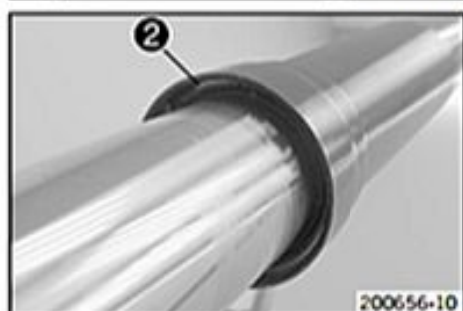

- Mount lock ring ②.

i Info

The lock ring must audibly lock into place.

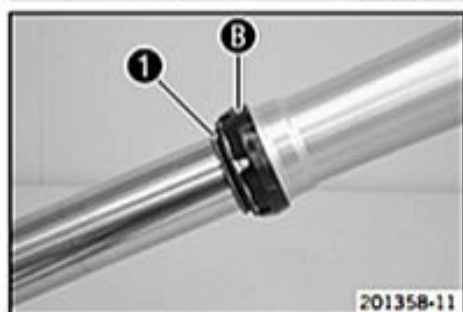

- Install dust boot ①.
- Mount fork protector ring B.

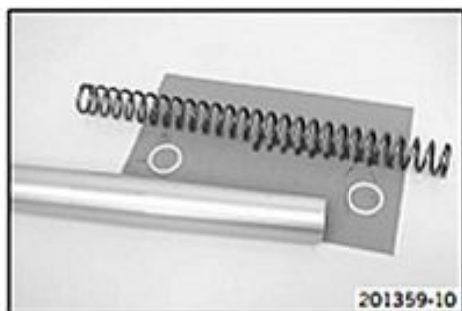

- Mount the preload spacers and spring.

Guideline

Spring rate		
Weight of rider: 65... 75 kg (143... 165 lb.)		4.6 N/mm (26.3 lb/in)
Weight of rider: 75... 85 kg (165... 187 lb.)		4.8 N/mm (27.4 lb/in)
Weight of rider: 85... 95 kg (187... 209 lb.)		5.0 N/mm (28.6 lb/in)

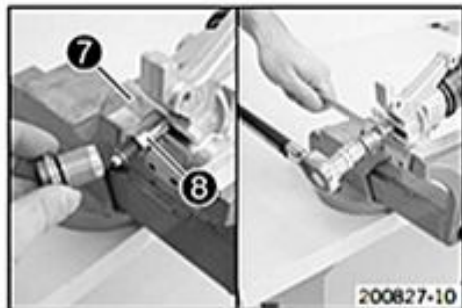

- Push the cartridge into the fork leg.
- Press the cartridge against the spring and mount special tool 7.

Support tool (T14020) (☛ p. 273)

- Grease the O-ring of the rebound adjuster.

Lubricant (T158) (☛ p. 260)

- Mount the rebound adjuster.
 - ✓ The rebound adjuster must reach the stop before the piston rod turns with it. In case of tight piston rod threads, it must be held to keep it from turning.
 - ✗ If the rebound adjuster is not turned all the way to the stop, the rebound damping cannot be correctly adjusted.

- Hold onto nut 8 and tighten the rebound adjuster.

Guideline

Rebound adjuster on the piston rod	M12x1	30 Nm (22.1 lbf ft)
------------------------------------	-------	---------------------

- Press the cartridge against the spring and remove special tool 7.
- Tighten the rebound adjuster.

Guideline

Rebound adjuster on the axle clamp	M20x1	30 Nm (22.1 lbf ft)
------------------------------------	-------	---------------------

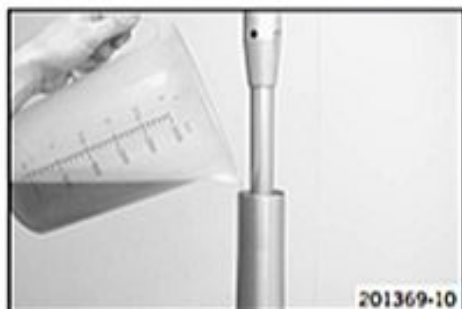
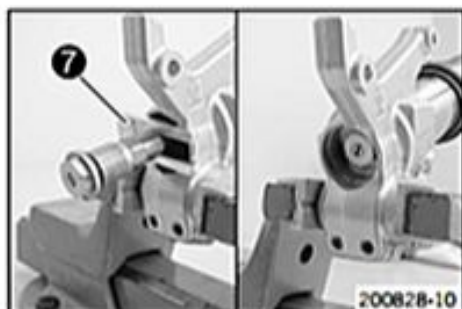

- Clamp in the fork vertically.

Guideline

Use soft jaws.

- Fill with fork oil.

Oil capacity fork leg without cartridge	400 ml (13.52 fl. oz.)	Fork oil (SAE 4) (48601166S1) (☛ p. 258)
---	------------------------	--



- Lubricate O-ring 9 of the cartridge.

Lubricant (T158) (☛ p. 260)

- Push the outer tube upward.
- Clamp the outer tube in the area of the lower triple clamp.

Clamping stand (T1403S) (☛ p. 275)

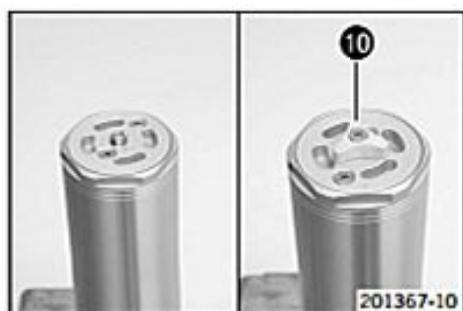

- Tighten the cartridge.

Guideline

Cartridge on the outer tube	M51x1.5	50 Nm (36.9 lbf ft)
-----------------------------	---------	------------------------

Ring wrench (T14017) (☞ p. 273)

- Mount adjuster 10 of the compression damping. Mount and tighten the screw.

Guideline

Screw, compression adjuster	M4x0.5	1.5 Nm (1.11 lbf ft)
-----------------------------	--------	-------------------------



Alternative 1

- Turn adjusting screw of compression damping 11 and adjusting screw of rebound damping 12 clockwise all the way.
- Turn back counterclockwise by the number of clicks corresponding to the fork type.

Guideline

Rebound damping	
Comfort	14 clicks
Standard	12 clicks
Sport	10 clicks
Compression damping	
Comfort	14 clicks
Standard	12 clicks
Sport	10 clicks

Alternative 2



Warning

Danger of accidents Modifications to the suspension settings can seriously alter the vehicle's ride behavior.

- Extreme modifications to the adjustment of the suspension components can cause a serious deterioration in the handling characteristics and overload some components.
 - Only make adjustments within the recommended range.
 - After making adjustments, ride slowly at first to get the feel of the new ride behavior.
-
- Set the adjusting screws to the position determined before removal.
 - Mount protection cap 13.

6.9.16 Bleeding and filling the cartridge



Info

Before working with the vacuum pump, carefully read the vacuum pump operating manual.

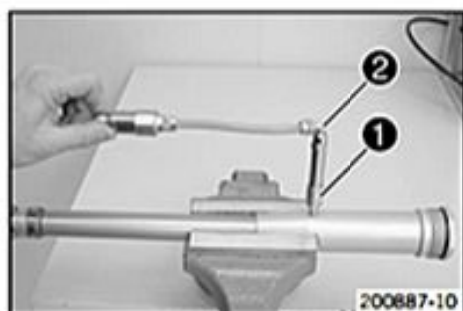

- Clamp the cartridge as shown in the figure.

Guideline

Use soft jaws.



Info

Clamp the cartridge only lightly.

The filling port must be located at the highest point.

During the filling procedure, the cartridge must be lower than the oil tank of the vacuum pump.

The piston rod moves in and out during filling; do not immobilize it by holding it with your hand.

- Remove the screw of the filling port.

- Mount special tool ① on the cartridge.

Filling adapter (T14030) (☞ p. 274)



Info

Hand-tighten only without using a tool.

- Connect adapter ② to special tool ①.
- Connect adapter ② to the filling port of vacuum pump ⑧.

Vacuum pump (T1240S) (☞ p. 272)

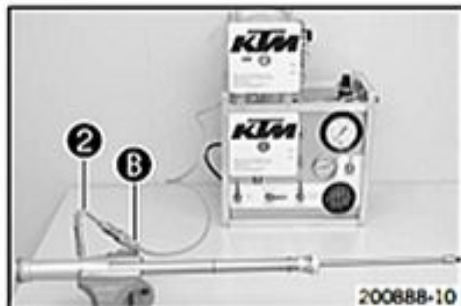

- Clamp the control lever as shown in the figure.
 - ✓ Control lever External tank ③ is set to Closed; Damper ④ is set to Vacuum; and Oil reservoir ⑤ is set to Vacuum.
- Activate On/Off switch ⑥.
 - ✓ The suction process begins.
 - ✓ Pressure gauge ⑦ drops to the required value.

< 0 bar

- ✓ Vacuum gauge ⑧ drops to the required value.

10 mbar

- When the vacuum gauge reaches the required value, turn control lever Oil reservoir ⑤ to Equalize pressure.

Guideline

10 mbar

- ✓ The pressure gauge increases to the required value.

0 bar

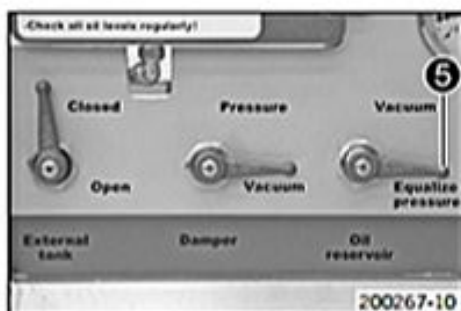

- When the pressure gauge reaches the required value, turn control lever Damper ④ to Pressure.

Guideline

0 bar

- ✓ Oil is pumped into the cartridge.
- ✓ The pressure gauge increases to the required value.

3 bar

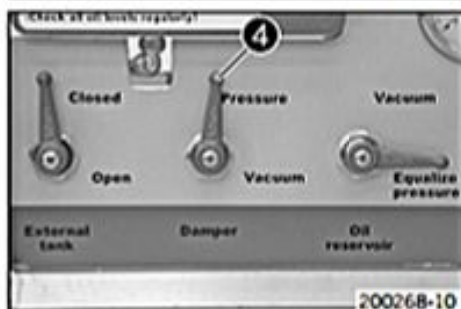

- When the pressure gauge reaches the required value, turn control lever Damper ④ to Vacuum.

Guideline

3 bar

- ✓ The pressure gauge drops to the required value.

0 bar

- When the pressure gauge reaches the required value, activate the On/Off switch.

Guideline

0 bar

- ✓ The vacuum pump is switched off.

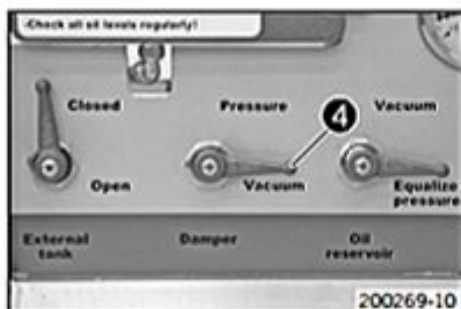

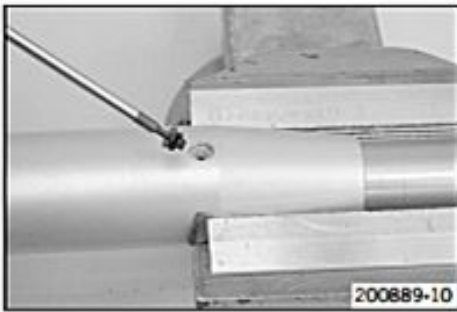

- Disconnect the vacuum pump. Remove the special tool.



Info

The filling port must be positioned at the highest point.

- Mount and tighten the filling screw with the O-ring.

Guideline

Cartridge filling screw	M4x0.5	2 Nm (1.5 lbf ft)
-------------------------	--------	-------------------

6.9.17 Filling the cartridge with nitrogen

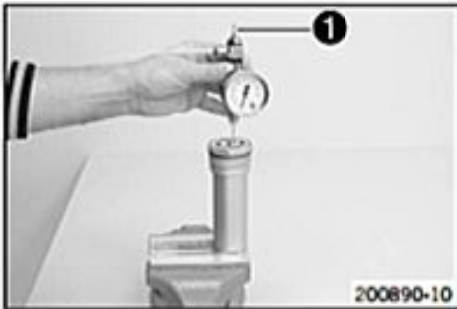

- Clamp the cartridge in a vise using soft jaws.



Info

Clamp the cartridge only lightly.

- Connect the connector of the special tool to the pressure regulator of the nitrogen bottle.

Nitrogen charging tool (T14019) (☛ p. 273)

Filling gas - nitrogen

- Adjust the pressure regulator of the nitrogen bottle.

Guideline

Gas pressure	1.2 bar (17 psi)
--------------	------------------

- Pierce the membrane with the needle of the special tool.

- Open valve ①.

- Fill the cartridge for at least 15 seconds.

Guideline

Gas pressure	1.2 bar (17 psi)
--------------	------------------



Info

Watch the pressure regulator dial.

Ensure that the cartridge is filled to the specified pressure.

- Close the valve.
- Close the nitrogen bottle.
- Remove the special tool.
- Mount and tighten filling screw ② with the O-ring.

Guideline

Nitrogen filling screw of the fork leg	M4x0.5	2.5 Nm (1.84 lbf ft)
--	--------	-------------------------



6.10 SX-F USA

6.10.1 Performing a fork service

Condition

The fork legs have been removed.

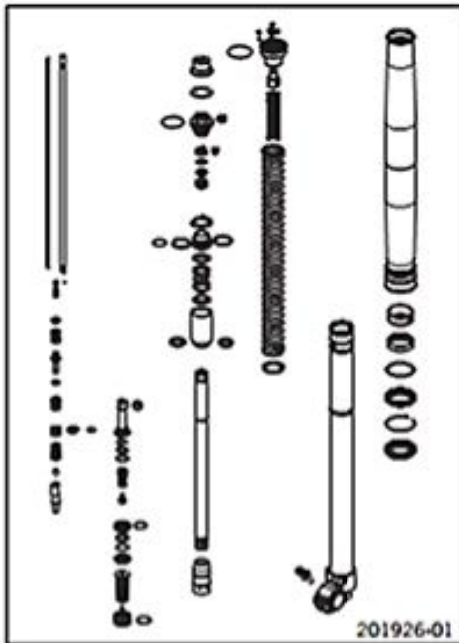

- Disassemble the fork legs. (☞ p. 38)
- Remove the spring. (☞ p. 40)
- Disassemble the cartridge. (☞ p. 41)
- Disassemble the piston rod. (☞ p. 43)
- Disassemble the hydrostop unit. (☞ p. 44)
- Disassemble the seal ring retainer. (☞ p. 45)
- Check the fork legs. (☞ p. 45)
- Assemble the seal ring retainer. (☞ p. 46)
- Assemble the hydrostop unit. (☞ p. 46)
- Assemble the piston rod. (☞ p. 47)
- Assemble the cartridge. (☞ p. 48)
- Assemble the fork legs. (☞ p. 49)

6.10.2 Disassembling the fork legs

i Info
The steps are identical for both fork legs.

Condition
The fork legs are disassembled.

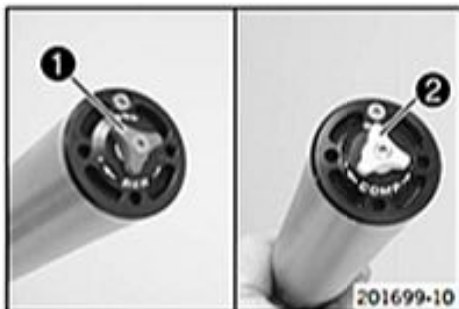

- Note down the current state of rebound damping **1** REB (red adjuster of right fork leg).
- Note down the current state of compression damping **2** COMP (white adjuster of left fork leg).
- Fully open the adjusters of the rebound and compression damping.



- Clamp the fork leg in the area of the lower triple clamp.

Clamping stand (T1403S) (☞ p. 275)

- Remove the screw. Remove adjuster **3**.



- Release screw cap **4**.

Special socket (T14047) (☞ p. 275)

i Info
The cartridge cannot be taken off yet.



- Unclamp the fork leg.
- Push the outer tube down. Drain the fork oil.

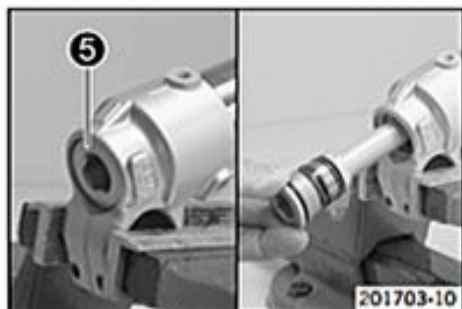

- Clamp the fork leg with the axle clamp.
- Release hydrostop unit **5** and remove it.



Info

Do not use an impact wrench.
Place a pan underneath since oil will run out.

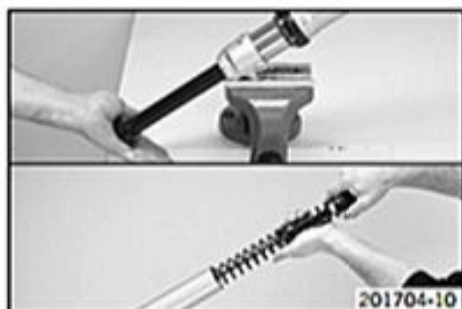

- Remove the cartridge from the fork leg.

Press-out tool (T14051) (☞ p. 275)



Info

Removing the O-ring seat from the cartridge usually requires the application of force.

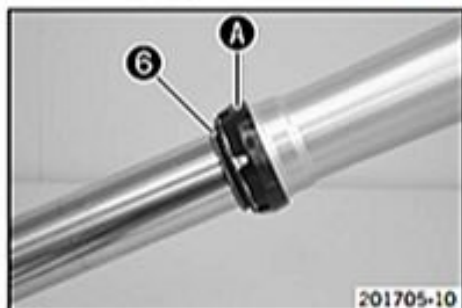

- Remove dust boot **6**.
- Remove fork protection ring **A**.



Info

The fork protection ring does not necessarily need to be removed for repair work.



- Remove lock ring **7**.



Info

The lock ring has a ground end against which a screwdriver can be positioned.



- Warm the outer tube in area **B** of the lower sliding bushing.

Guideline

50 °C (122 °F)

- Pull the outer tube forcefully off of the inner tube.



Info

The lower sliding bushing **8** must be pulled out of its bearing seat.



- Remove the upper sliding bushing 9.



Info

Do not use a tool; pull the ends apart slightly by hand.



- Take off the lower sliding bushing 8.
- Take off support ring 10.
- Take off seal ring 11.
- Take off lock ring 7.
- Take off dust boot 6.
- Unclamp the fork leg.

6.10.3 Removing the spring



Info

The steps are identical for both fork legs.

Preparatory work

- Disassemble the fork legs. (☛ p. 38)

Main work

- Pull the spring down. Mount the open end wrench on the hexagonal part.

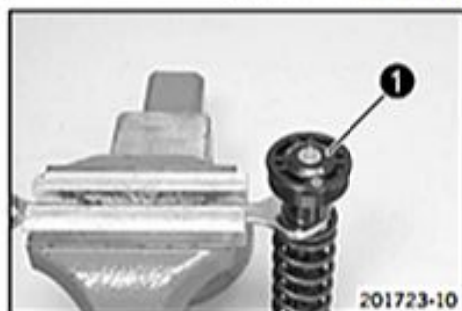

- Clamp the open end wrench in the vise. Release screw cap 1 but do not remove it yet.

Special socket (T14047) (☛ p. 275)



- Pull the spring down. Remove the open end wrench.
- Remove the screw cap.
- Remove the spring with the preload spacer(s).

6.10.4 Disassembling the cartridge

i Info
The steps are identical for both fork legs.

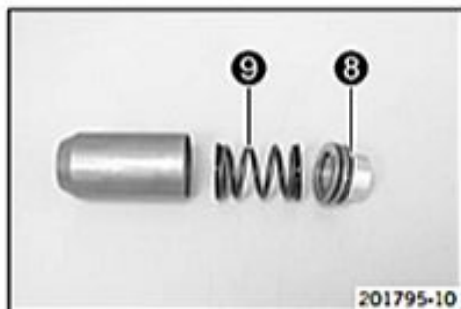
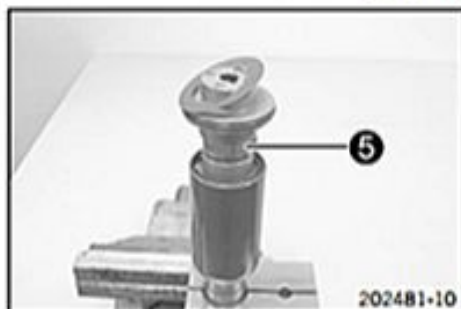
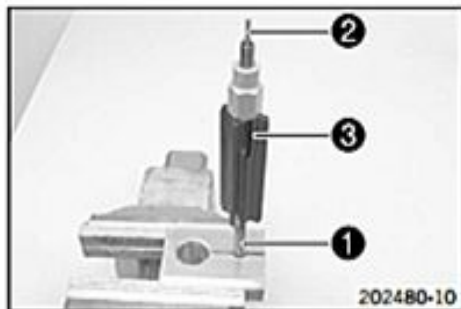

Preparatory work

- Disassemble the fork legs. (☞ p. 38)
- Remove the spring. (☞ p. 40)

Main work

- Degrease piston rod ① and clamp it in the vise.

Clamping stand (T14049S) (☞ p. 275)

- Remove adjusting tube ②. Unscrew spring guide ③.

- Remove spring seat ④.
- Pull the piston rod out of the cartridge.

- Clamp the tube of the cartridge into a vise.

Clamping stand (T14049S) (☞ p. 275)

- Release seal ring retainer ⑤ and remove with the washer.

- Remove lock ring ⑥.
- Pull reservoir ⑦ off of the tube.

- Pull sleeve ⑧ out of the reservoir.
- Remove spring ⑨.

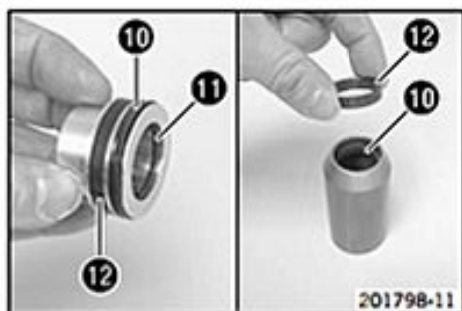

- Remove seal rings 10 and O-ring 11.
- Remove pilot bushings 12.

6.10.5 Disassembling the cartridge

i Info
The steps are identical for both fork legs.

Preparatory work

- Disassemble the fork legs. (☞ p. 38)
- Remove the spring. (☞ p. 40)

Main work

- Degrease piston rod 1 and clamp it in the vise.

Clamping stand (T14049S) (☞ p. 275)

- Remove adjusting tube 2. Unscrew spring guide 3.

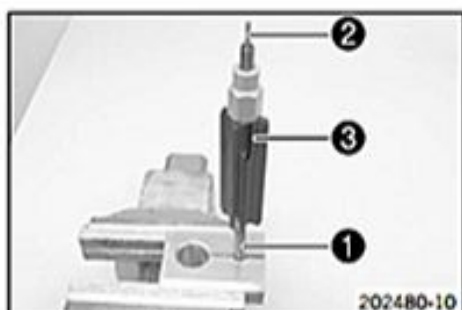

- Remove spring seat 4.
- Pull the piston rod out of the cartridge.

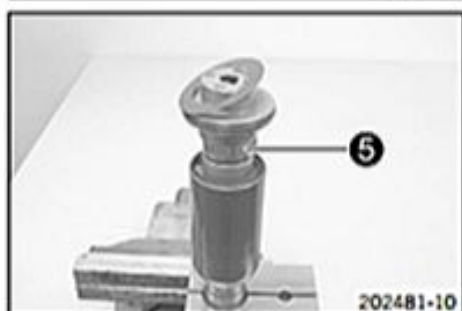

- Clamp the tube of the cartridge into a vise.

Clamping stand (T14049S) (☞ p. 275)

- Release seal ring retainer 5 and remove with the washer.



- Remove lock ring 6.
- Pull reservoir 7 off of the tube.

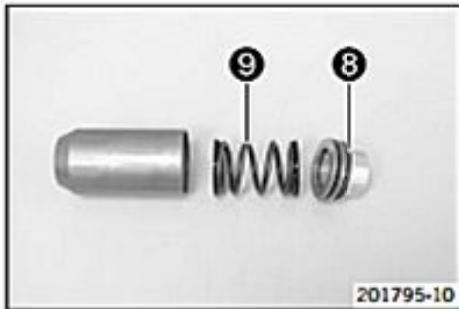

- Pull sleeve 8 out of the reservoir.
- Remove spring 9.

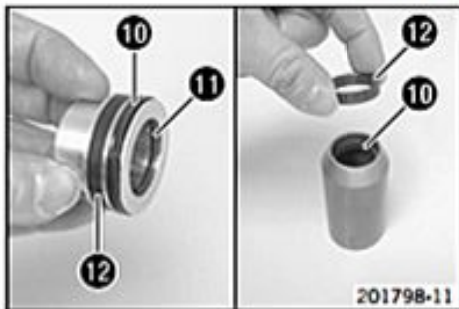

- Remove seal rings 10 and O-ring 11.
- Remove pilot bushings 12.

6.10.6 Disassembling the piston rod



Info

The steps are identical for both fork legs, except for the hydrostop needle and valve.

Preparatory work

- Disassemble the fork legs. (☛ p. 38)
- Remove the spring. (☛ p. 40)
- Disassemble the cartridge. (☛ p. 42)

Main work

- Degrease the piston rod.
- Clamp the piston rod with the special tool as far up as possible.

Clamping stand (T14049S) (☛ p. 275)

- Release hydrostop needle 1 and remove it from the piston rod.
- ✓ The valve 2 usually remains in the hydrostop needle.

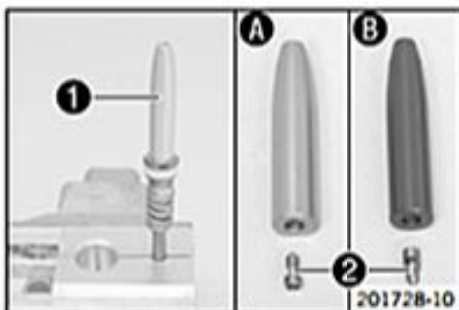

Info

- A - silver hydrostop needle on compression damping side.
- B - red hydrostop needle on rebound damping side.

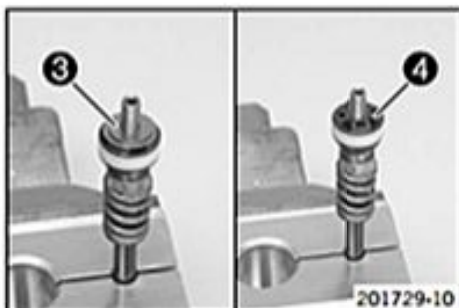

- Remove the rebound shim stack 3.
- Remove piston 4.

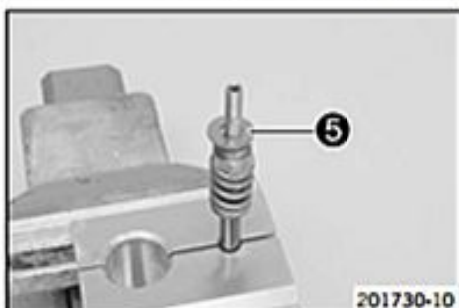

- Remove the compression shim stack 5.
- Remove spring.

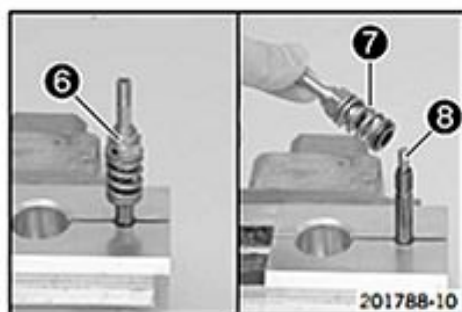

- Remove adapter ⑥ with spring ⑦ and washer.
- Remove spring ⑧.

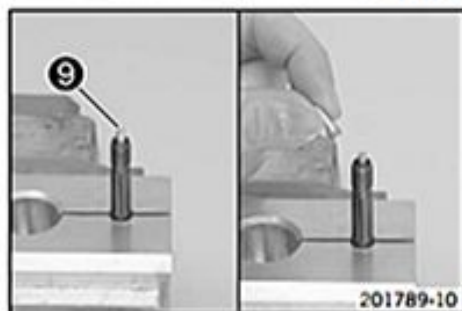

- Remove valve needle ⑨ from the piston rod.

Info

The adjusting tube can be used for this.

6.10.7 Disassembling the hydrostop unit

Info

The steps are identical for both fork legs.

Preparatory work

- Disassemble the fork legs. (☛ p. 38)

Main work

- Mount the hydrostop unit on a fitting hexagon socket and clamp into a vice.
- Remove sleeve ①.
- Remove shim stack ②.

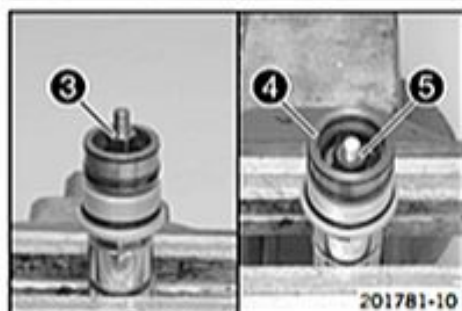
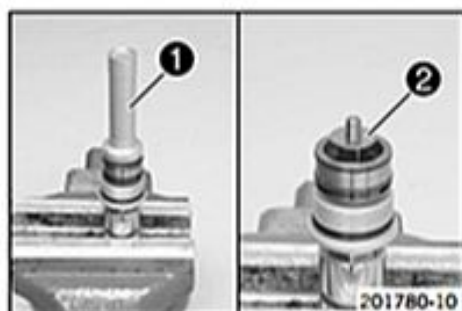

- Remove adapter ③.
- Remove hub ④ with washers ⑤.

Info

It is possible that only one washer or no washer is present.

- Remove the O-ring from the hub.

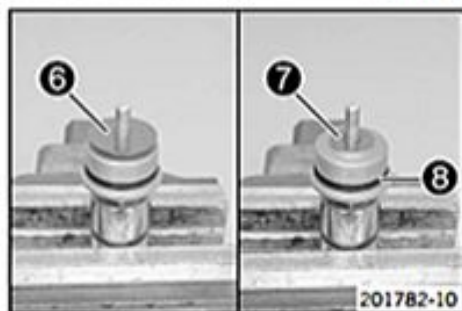

- Remove shim stack ⑥.
- Remove washer ⑦.
- Remove O-ring ⑧.

6.10.8 Disassembling the seal ring retainer

i Info
The steps are identical for both fork legs.

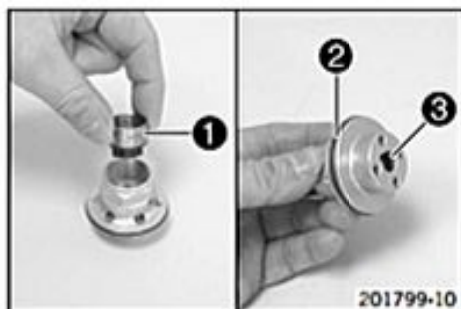

Preparatory work

- Disassemble the fork legs. (☛ p. 38)
- Remove the spring. (☛ p. 40)
- Disassemble the cartridge. (☛ p. 42)

Main work

- Remove pilot bushing support ①.
- Remove O-ring ② and seal ring ③.

6.10.9 Checking the fork legs

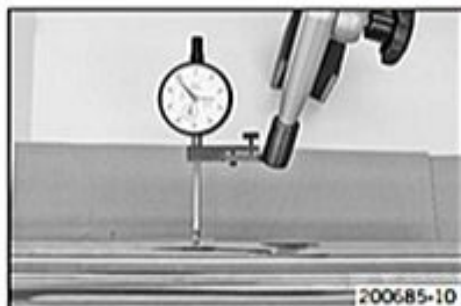
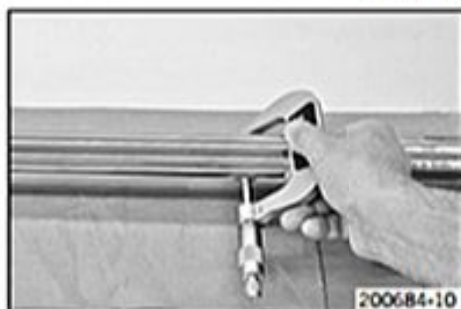
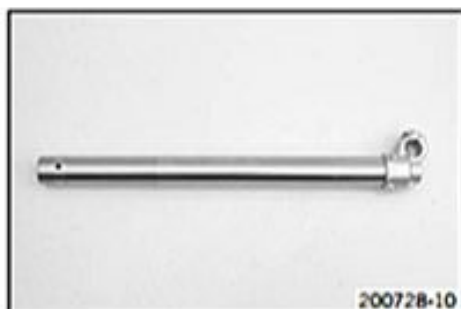

Condition

The fork legs have been disassembled.

- Check the inner tube and axle clamp for damage.
 - If there is damage:
 - Change the inner tube.

- Measure the outside diameter at multiple locations of the inner tube.

Outside diameter of inner tube	47.975... 48.005 mm (1.88878... 1.88996 in)
--------------------------------	---

- If the measured value is smaller than the specified value:
 - Change the inner tube.

- Measure the run-out of the inner tube.

Inner tube run-out	≤ 0.20 mm (≤ 0.0079 in)
--------------------	-------------------------

- If the measured value is larger than the specified value:
 - Change the inner tube.

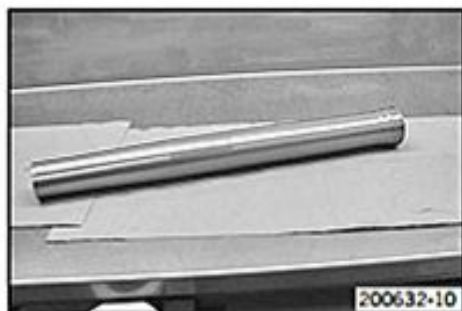

- Measure the inside diameter at multiple locations of the outer tube.

Inside diameter of outer tube	≤ 49.20 mm (≤ 1.937 in)
-------------------------------	-------------------------

- If the measured value is larger than the specified value:
 - Change the outer tube.
- Check the outer tube for damage.
 - If there is damage:
 - Change the outer tube.



- Check the surface of the sliding bushings.
 - If the bronze-colored layer **A** under sliding layer **B** is visible or the surface is rough:
 - Change the sliding bushings.

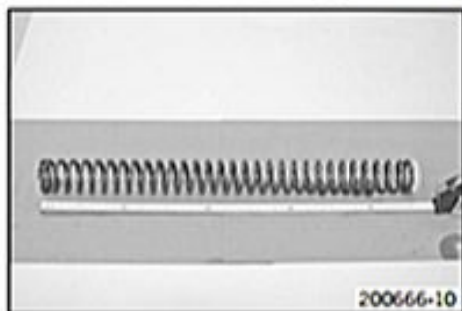

- Check the spring length.

Guideline

Spring length with preload spacer(s)	480 mm (18.9 in)
--------------------------------------	------------------

- If the measured value is larger than the specified value:
 - Reduce the thickness of the preload spacers.
 - If the measured value is smaller than the specified value:
 - Increase the thickness of the preload spacers.

6.10.10 Assembling the seal ring retainer

i Info
The steps are identical for both fork legs.

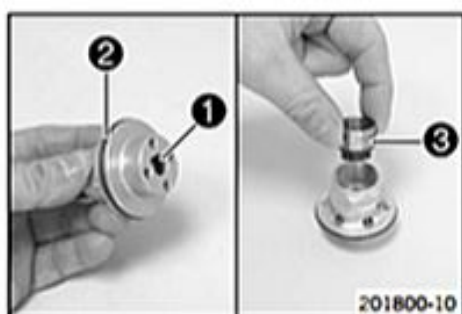

- Mount and grease seal ring **1**.
Lubricant (T158) (☞ p. 260)
- Mount and grease O-ring **2**.
Lubricant (T158) (☞ p. 260)
- Position pilot bushing support **3**.

6.10.11 Assembling the hydrostop unit

i Info
The steps are identical for both fork legs.

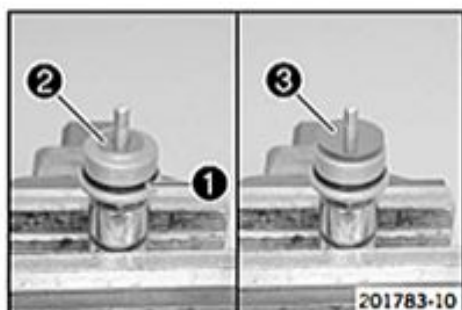

- Mount and grease O-ring **1**.
Lubricant (T158) (☞ p. 260)
- Mount washer **2**.
- Mount shim stack **3** with the smaller washers facing downward.

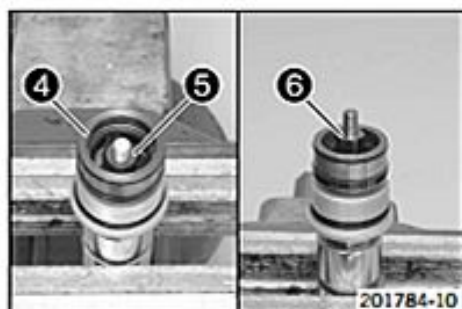

- Mount the new O-ring on hub ④.
- Mount the hub with washers ⑤.

**Info**

It is possible that only one or no washer is present.

- Mount and tighten adapter ⑥.

Guideline

Hydrostop unit adapter	M6x0.5	7 Nm (5.2 lbf ft)
------------------------	--------	-------------------

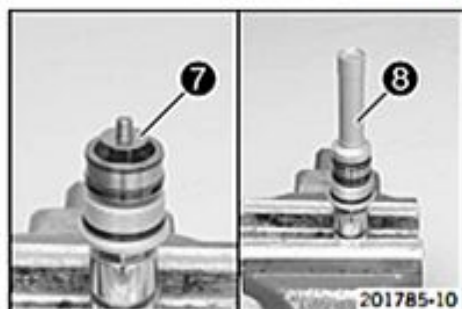

- Mount shim stack ⑦ with the smaller washers facing downward.
- Mount and tighten sleeve ⑧.

Guideline

Hydrostop unit sleeve	M6x0.5	7 Nm (5.2 lbf ft)
-----------------------	--------	-------------------

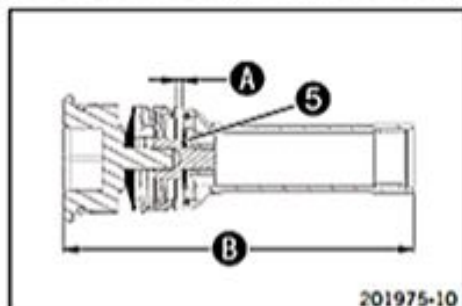

- Check distance A and total length B of the hydrostop.

Guideline

Hydrostop distance	$\geq 1.5 \text{ mm}$ ($\geq 0.059 \text{ in}$)
Hydrostop length	108.5... 109.5 mm (4.272... 4.311 in)

- If the dimensions are out of tolerance:
 - Add or remove washers ⑤.

6.10.12 Assembling the piston rod**Info**

The steps are identical for both fork legs, except for the hydrostop needle and valve.

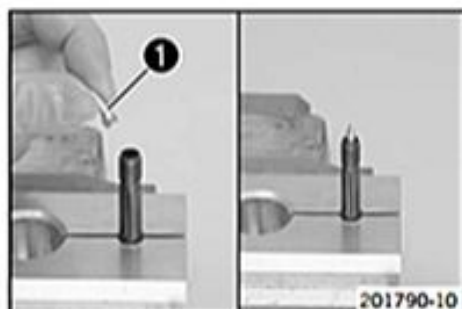

- Degrease the piston rod.
- Clamp the piston rod with the special tool.

Clamping stand (T14049S) (☞ p. 275)

- Lubricate the O-ring. Mount valve needle ① in the piston rod.

Lubricant (T158) (☞ p. 260)

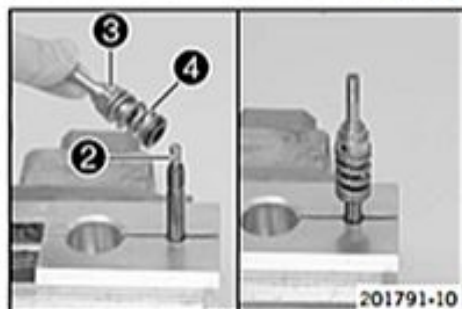

- Mount spring ②.
- Mount and tighten adapter ③ with spring ④ and washer.

Guideline

Adapter of piston rod	M6x0.5	12 Nm (8.9 lbf ft)
-----------------------	--------	--------------------

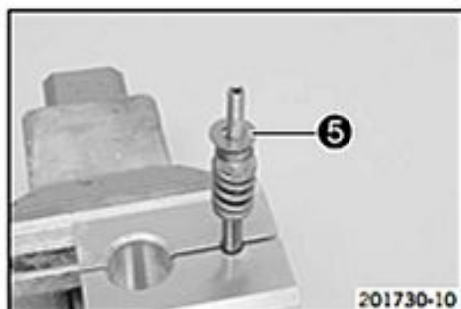

- Position the spring.
- Mount the compression shim stack **5** with the smaller washers facing downward.

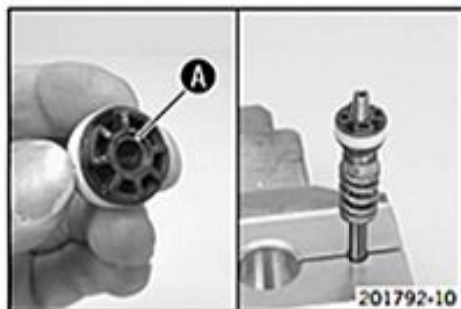

- Grind the piston on both sides on a surfacing plate using 1200 grit sandpaper.
- Clean the piston.
- Lubricate the piston ring.

Fork oil (SAE 4) (48601166S1) (☞ p. 258)

- Mount the piston with chamfer **A** facing down.

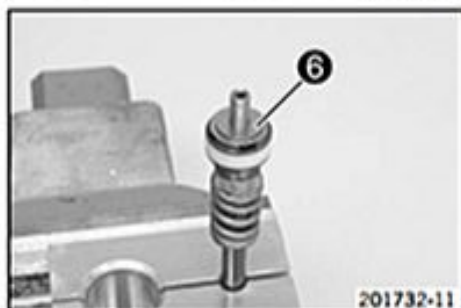

- Mount the rebound shim stack **6** with the smaller washers facing upward.

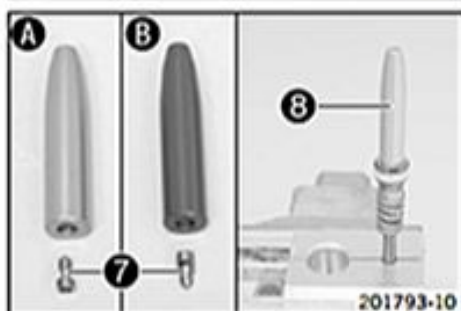

- Press the piston downward against the spring.
✓ The piston should not squeeze the shims.
- Position valve **7** in the hydrostop needle **8**. Mount and tighten the hydrostop needle.

Guideline

Hydrostop needle on piston rod	M6x0.5	7 Nm (5.2 lbf ft)
--------------------------------	--------	-------------------



Info

- A** - silver hydrostop needle on compression damping side.
- B** - red hydrostop needle on rebound damping side.

- Unclamp the piston rod.

6.10.13 Assembling the cartridge



Info

The steps are identical for both fork legs.

Preparatory work

- Assemble the seal ring retainer. (☞ p. 46)
- Assemble the piston rod. (☞ p. 47)

Main work

- Mount and grease seal rings **1** and O-ring **2**.

Lubricant (T158) (☞ p. 260)

- Mount and lubricate pilot bushings **3**.

Fork oil (SAE 4) (48601166S1) (☞ p. 258)

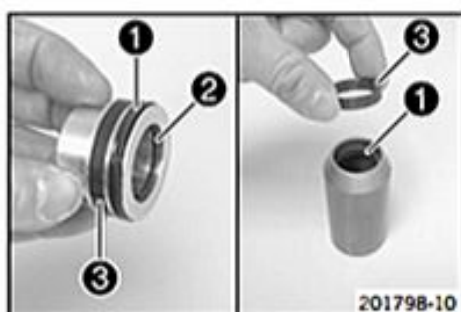



- Check the length of the reservoir spring.

Guideline

Reservoir spring length with preload spacer	46 mm (1.81 in)
---	-----------------

- If the length is out of tolerance:
 - Correct the preload spacers.
- Position the spring with the preload spacers in the reservoir.
- Position sleeve (4) in the reservoir.

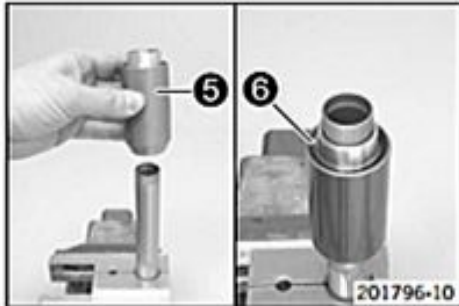

- Clamp the tube of the cartridge into a vise.

Clamping stand (T14049S) (☛ p. 275)

- Slide reservoir (5) onto the tube.

i Info
Hold the sleeve in the reservoir to prevent it from sliding out.

- Mount lock ring (6).



- Mount seal ring retainer (7) with the washer and tighten.

Guideline

Seal ring retainer	M23.5x0.75	46 Nm (33.9 lbf ft)	Loctite® 2701™
--------------------	------------	---------------------	----------------

- Unclamp the cartridge.



- Slide piston rod (8) into the cartridge.

i Info
Ensure that the piston ring is seated correctly.

- Mount spring seat (9).

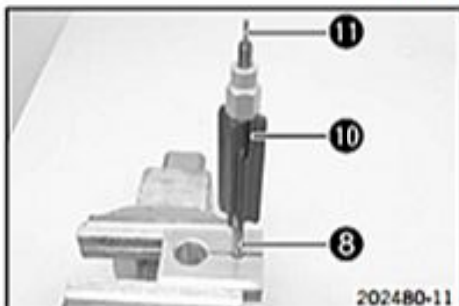

- Degrease piston rod (8) and clamp in the vise.

Clamping stand (T14049S) (☛ p. 275)

- Screw spring guide (10) all the way on.

i Info
The nut must be firmly tightened against the stop by hand. Do not use a tool.

- Mount adjusting tube (11).
- Unclamp the piston rod. Mount the preload spacer(s).

6.10.14 Assembling the fork legs

i Info
When assembling, ensure that the right cartridge is mounted in the corresponding inner tube and the right adjuster is mounted on the corresponding screw cap.
Compression damping side – screw cap with mark **COMP**, brake caliper holder, white adjuster.
Rebound damping side – screw cap with mark **REB**, no brake caliper holder, red adjuster.

- Preparatory work**
- Assemble the hydrostop unit. (☛ p. 46)



Main work

- Clamp the inner tube with the axle clamp.

Guideline

Use soft jaws.

- Mount special tool.

Protecting sleeve (T1401) (☛ p. 272)

- Lubricate and mount dust boot ①.

Lubricant (T511) (☛ p. 260)



Info

Always change the dust boot, seal ring, lock ring and support ring. Mount the sealing lip with the spring expander facing downward.

- Slide on lock ring ②.
- Lubricate and slide on seal ring ③.

Lubricant (T511) (☛ p. 260)



Info

Mount with the sealing lip facing down and the open side facing up.

- Slide on support ring ④.
- Remove the special tool.
- Grind the edges of the sliding bushings with sandpaper grit 600, clean the bushings and lubricate them.

Fork oil (SAE 4) (48601166S1) (☛ p. 258)



- Slide on the lower sliding bushing ⑤.
- Mount the upper sliding bushing ⑥.



Info

Do not use a tool; pull the ends apart slightly by hand.



- Warm the outer tube in area A of the lower sliding bushing.

Guideline

50 °C (122 °F)

- Slide the outer tube onto the inner tube.
- Hold the lower sliding bushing with the longer section of the special tool.

Mounting tool (T14040S) (☛ p. 275)

- Push the sliding bushing all the way into the outer tube.



- Position the support ring.
- Hold the seal ring with the shorter section of the special tool.

Mounting tool (T14040S) (☞ p. 275)

- Push the seal ring and support ring all the way into the outer tube.

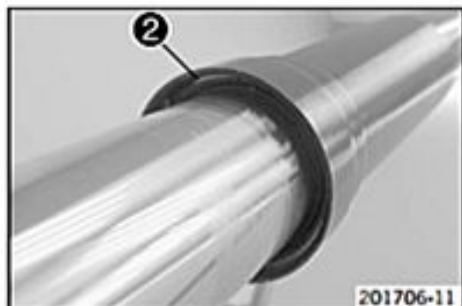

- Mount lock ring ②.



Info

The lock ring must engage audibly.

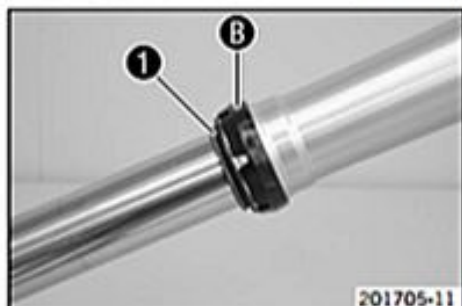

- Mount dust boot ①.
- Mount fork protection ring B.



- Lubricate the O-ring. Slide the cartridge all the way into the fork leg.

Fork oil (SAE 4) (48601166S1) (☞ p. 258)



- Turn the fork. Have the entire filling quantity of fork oil available.

Oil capacity per fork leg	665 ml (22.48 fl. oz.)	Fork oil (SAE 4) (48601166S1) (☞ p. 258)
---------------------------	------------------------	--

- Add some of the fork oil while pulling out and pushing in the piston rod numerous times.

Guideline

Fork oil quantity	510 ml (17.24 fl. oz.)
-------------------	------------------------

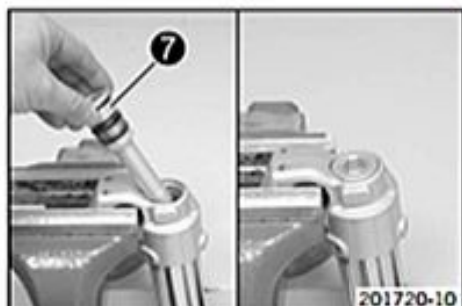

- Mount and tighten hydrostop unit ⑦.

Guideline

Hydrostop unit	M30x1	40 Nm (29.5 lbf ft)
----------------	-------	---------------------



- Clamp the fork vertically.
- Add the remaining quantity of fork oil.

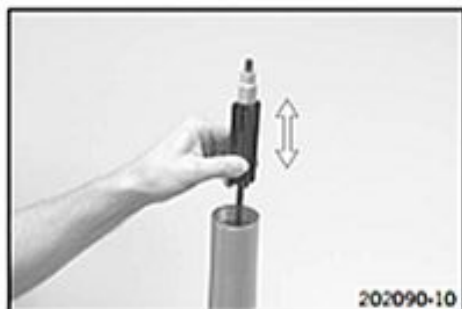

- Pull out the piston rod and push it back in numerous times while pressing it to one side slightly.
 - ✓ Air bubbles emerge and the cartridge is bled.
- Keep bleeding until no more air bubbles emerge.
 - ✓ The piston rod moves out automatically to the middle of the total stroke distance.

i Info

When fully bled, the correct air chamber length is achieved automatically.

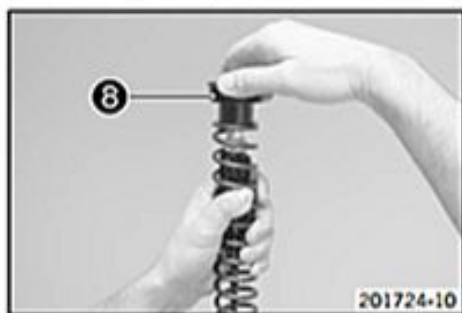

- Position spring.
- Pull the spring down. Mount screw cap 8.

i Info

When assembling, ensure that the screw caps are correctly mounted according to the hydrostop needles.
 Rebound damping side – red hydrostop needle, screw cap with mark **REB**.
 Compression damping side – silver hydrostop needle, screw cap with mark **COMP**.



- Pull the spring down. Mount the open end wrench on the hexagonal part.
- Hold the open end wrench. Tighten screw cap 8.

Guideline

Screw cap on piston rod	M8x0.75	18 Nm (13.3 lbf ft)
-------------------------	---------	------------------------

Special socket (T14047) (☛ p. 275)



- Push the outer tube up.
- Clamp the outer tube in the area of the lower triple clamp.

Clamping stand (T1403S) (☛ p. 275)

- Tighten screw cap 8.

Guideline

Cartridge on outer tube	M51x1.5	40 Nm (29.5 lbf ft)
-------------------------	---------	------------------------

Special socket (T14047) (☛ p. 275)



- Mount the adjuster. Mount and tighten screw 9.

Guideline

Screw, adjuster	M4x0.5	2.5 Nm (1.84 lbf ft)
-----------------	--------	-------------------------

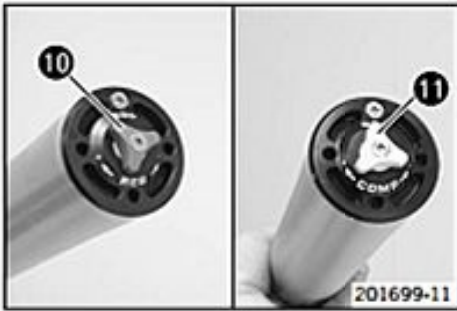

Alternative 1

- Turn the adjuster of compression damping **10** (mark **COMP**) and the adjuster of rebound damping **11** (mark **REB**) all the way clockwise.

Guideline

Rebound damping	
Comfort	17 clicks
Standard	15 clicks
Sport	13 clicks
Compression damping	
Comfort	17 clicks
Standard	15 clicks
Sport	13 clicks

- Turn counterclockwise by the number of clicks corresponding to the fork type.

Alternative 2



Warning

Danger of accidents Modifications to the suspension settings can seriously alter the vehicle's ride behavior.

- Extreme modifications to the adjustment of the suspension components can cause a serious deterioration in the handling characteristics and overload some components.
- Only make adjustments within the recommended range.
- After making adjustments, ride slowly at first to get the feel of the new ride behavior.

- Set the adjusters to the positions determined upon removal.

6.11 XC-F

6.11.1 Performing a fork service

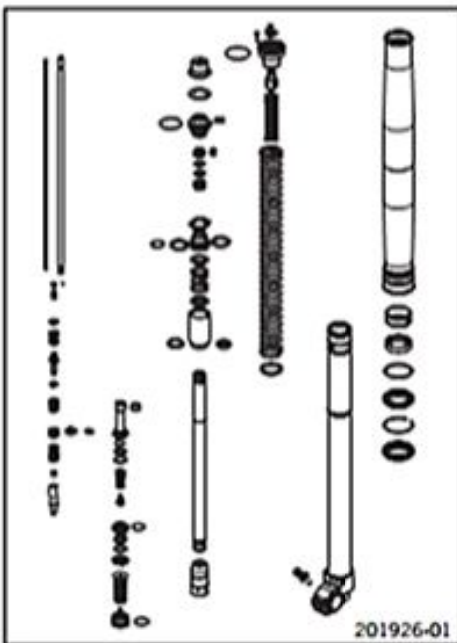

Condition

The fork legs have been removed.

- Disassemble the fork legs. (☞ p. 54)
- Remove the spring. (☞ p. 56)
- Disassemble the cartridge. (☞ p. 57)
- Disassemble the piston rod. (☞ p. 58)
- Disassemble the hydrostop unit. (☞ p. 59)
- Disassemble the seal ring retainer. (☞ p. 59)
- Check the fork legs. (☞ p. 60)
- Assemble the seal ring retainer. (☞ p. 61)
- Assemble the hydrostop unit. (☞ p. 61)
- Assemble the piston rod. (☞ p. 62)
- Assemble the cartridge. (☞ p. 63)
- Assemble the fork legs. (☞ p. 64)

6.11.2 Performing a fork service

Condition

The fork legs have been removed.

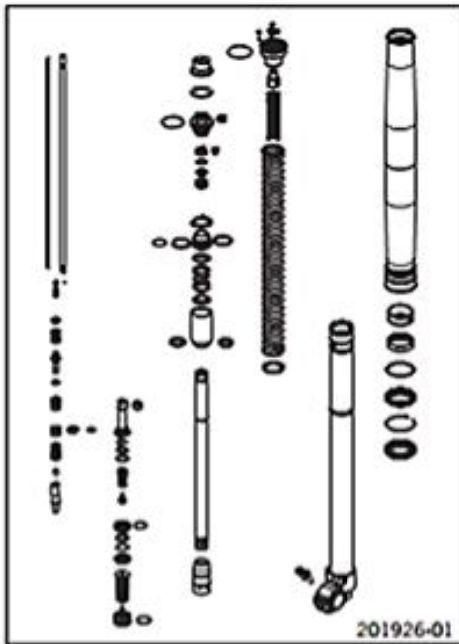

- Disassemble the fork legs. (☞ p. 54)
- Remove the spring. (☞ p. 56)
- Disassemble the cartridge. (☞ p. 57)
- Disassemble the piston rod. (☞ p. 58)
- Disassemble the hydrostop unit. (☞ p. 59)
- Disassemble the seal ring retainer. (☞ p. 59)
- Check the fork legs. (☞ p. 60)
- Assemble the seal ring retainer. (☞ p. 61)
- Assemble the hydrostop unit. (☞ p. 61)
- Assemble the piston rod. (☞ p. 62)
- Assemble the cartridge. (☞ p. 63)
- Assemble the fork legs. (☞ p. 64)

6.11.3 Disassembling the fork legs

i Info
The steps are identical for both fork legs.

Condition

The fork legs are disassembled.

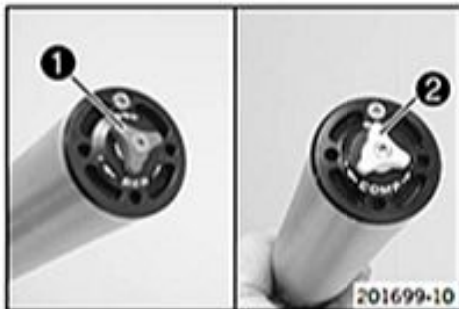

- Note down the current state of rebound damping **1** **REB** (red adjuster of right fork leg).
- Note down the current state of compression damping **2** **COMP** (white adjuster of left fork leg).
- Fully open the adjusters of the rebound and compression damping.



- Clamp the fork leg in the area of the lower triple clamp.

Clamping stand (T1403S) (☞ p. 275)

- Remove the screw. Remove adjuster **3**.



- Release screw cap **4**.

Special socket (T14047) (☞ p. 275)

i Info
The cartridge cannot be taken off yet.



- Unclamp the fork leg.
- Push the outer tube down. Drain the fork oil.

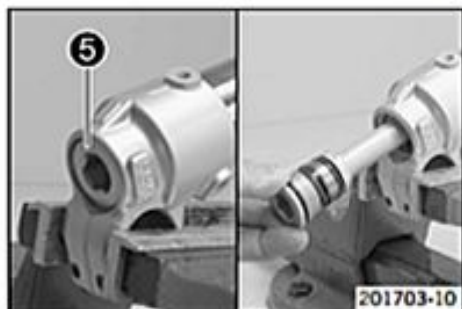

- Clamp the fork leg with the axle clamp.
- Release hydrostop unit **5** and remove it.



Info

Do not use an impact wrench.
Place a pan underneath since oil will run out.

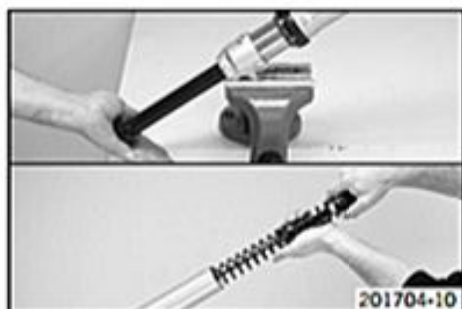

- Remove the cartridge from the fork leg.

Press-out tool (T14051) (← p. 275)



Info

Removing the O-ring seat from the cartridge usually requires the application of force.

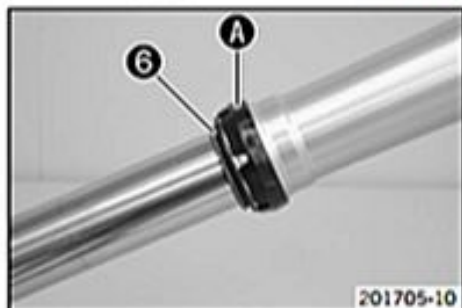

- Remove dust boot **6**.
- Remove fork protection ring **A**.



Info

The fork protection ring does not necessarily need to be removed for repair work.



- Remove lock ring **7**.



Info

The lock ring has a ground end against which a screwdriver can be positioned.



- Warm the outer tube in area **B** of the lower sliding bushing.

Guideline

50 °C (122 °F)

- Pull the outer tube forcefully off of the inner tube.



Info

The lower sliding bushing **8** must be pulled out of its bearing seat.



- Remove the upper sliding bushing 9.



Info

Do not use a tool; pull the ends apart slightly by hand.



- Take off the lower sliding bushing 8.
- Take off support ring 10.
- Take off seal ring 11.
- Take off lock ring 7.
- Take off dust boot 6.
- Unclamp the fork leg.

6.11.4 Removing the spring



Info

The steps are identical for both fork legs.

Preparatory work

- Disassemble the fork legs. (☛ p. 54)

Main work

- Pull the spring down. Mount the open end wrench on the hexagonal part.

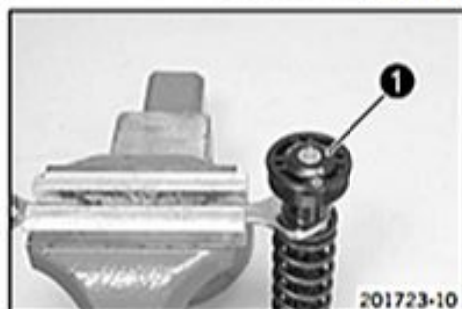

- Clamp the open end wrench in the vise. Release screw cap 1 but do not remove it yet.

Special socket (T14047) (☛ p. 275)



- Pull the spring down. Remove the open end wrench.
- Remove the screw cap.
- Remove the spring with the preload spacer(s).

6.11.5 Disassembling the cartridge

i Info
The steps are identical for both fork legs.

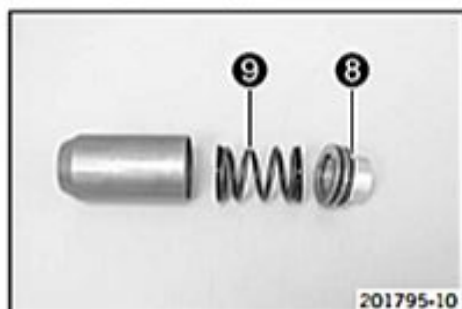
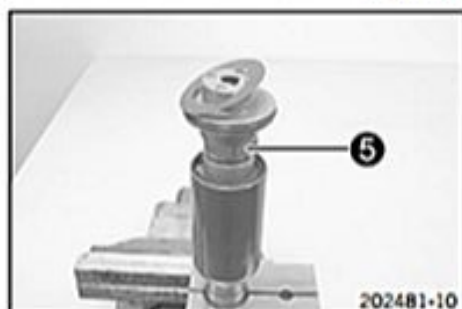
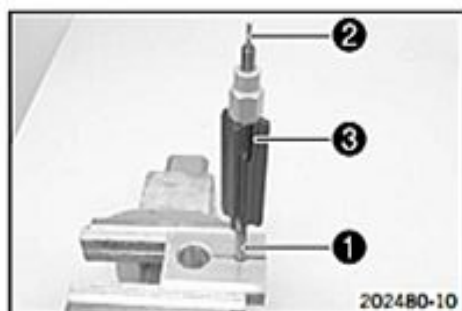

Preparatory work

- Disassemble the fork legs. (☞ p. 54)
- Remove the spring. (☞ p. 56)

Main work

- Degrease piston rod ① and clamp it in the vise.

Clamping stand (T14049S) (☞ p. 275)

- Remove adjusting tube ②. Unscrew spring guide ③.

- Remove spring seat ④.
- Pull the piston rod out of the cartridge.

- Clamp the tube of the cartridge into a vise.

Clamping stand (T14049S) (☞ p. 275)

- Release seal ring retainer ⑤ and remove with the washer.

- Remove lock ring ⑥.
- Pull reservoir ⑦ off of the tube.

- Pull sleeve ⑧ out of the reservoir.
- Remove spring ⑨.

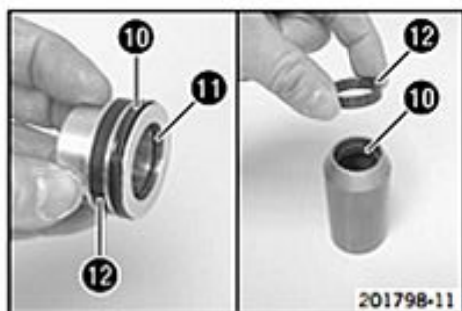

- Remove seal rings 10 and O-ring 11.
- Remove pilot bushings 12.

6.11.6 Disassembling the piston rod



Info

The steps are identical for both fork legs, except for the hydrostop needle and valve.

Preparatory work

- Disassemble the fork legs. (☛ p. 54)
- Remove the spring. (☛ p. 56)
- Disassemble the cartridge. (☛ p. 57)

Main work

- Degrease the piston rod.
- Clamp the piston rod with the special tool as far up as possible.

Clamping stand (T14049S) (☛ p. 275)

- Release hydrostop needle 1 and remove it from the piston rod.
- ✓ The valve 2 usually remains in the hydrostop needle.

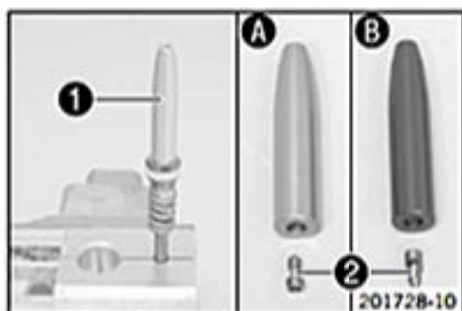

Info

- A - silver hydrostop needle on compression damping side.
- B - red hydrostop needle on rebound damping side.

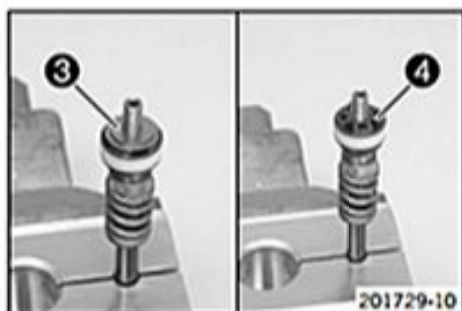

- Remove the rebound shim stack 3.
- Remove piston 4.

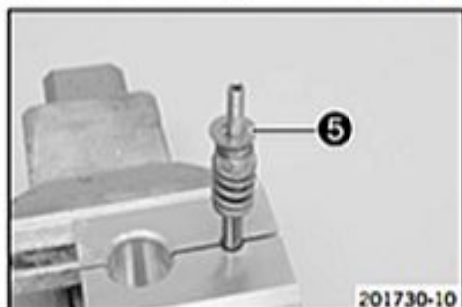

- Remove the compression shim stack 5.
- Remove spring.

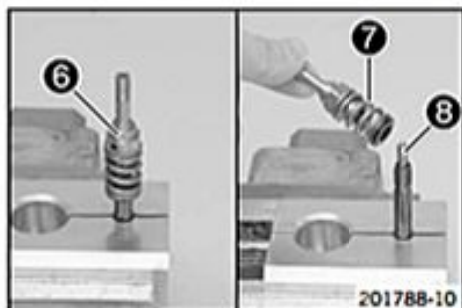

- Remove adapter 6 with spring 7 and washer.
- Remove spring 8.

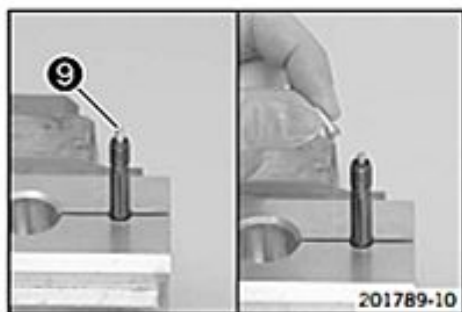

- Remove valve needle 9 from the piston rod.

Info

The adjusting tube can be used for this.

6.11.7 Disassembling the hydrostop unit

Info

The steps are identical for both fork legs.

Preparatory work

- Disassemble the fork legs. (☛ p. 54)

Main work

- Mount the hydrostop unit on a fitting hexagon socket and clamp into a vice.
- Remove sleeve 1.
- Remove shim stack 2.

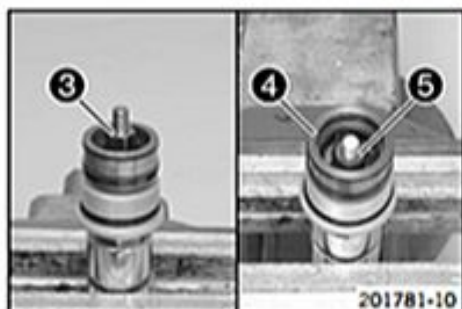
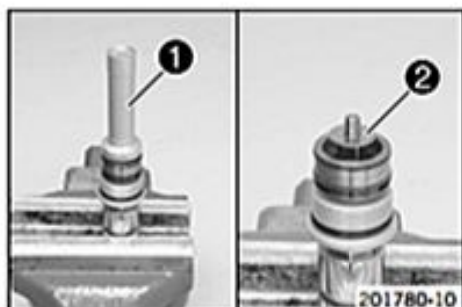

- Remove adapter 3.
- Remove hub 4 with washers 5.

Info

It is possible that only one washer or no washer is present.

- Remove the O-ring from the hub.

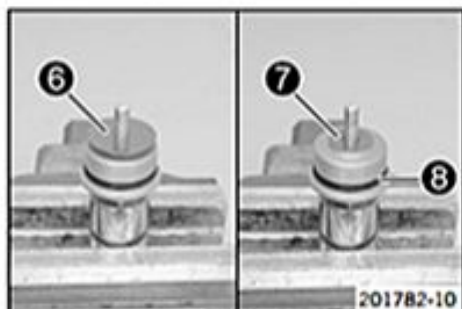

- Remove shim stack 6.
- Remove washer 7.
- Remove O-ring 8.

6.11.8 Disassembling the seal ring retainer

Info

The steps are identical for both fork legs.

Preparatory work

- Disassemble the fork legs. (☛ p. 54)
- Remove the spring. (☛ p. 56)
- Disassemble the cartridge. (☛ p. 57)

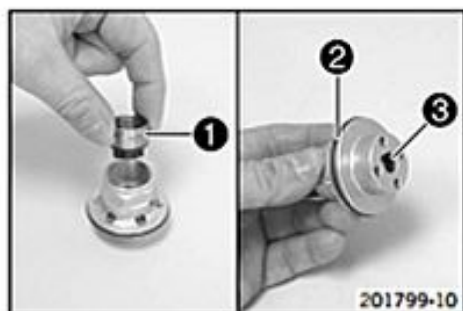

Main work

- Remove pilot bushing support **1**.
- Remove O-ring **2** and seal ring **3**.

6.11.9 Checking the fork legs

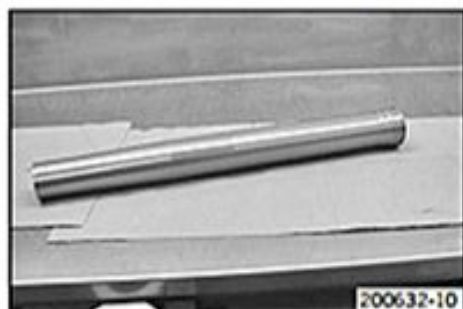
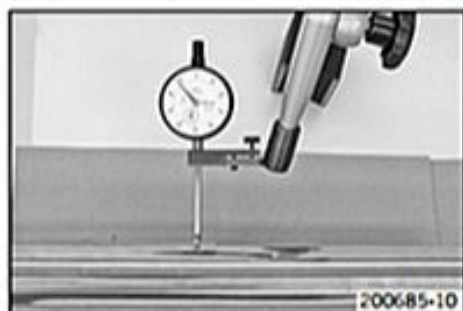
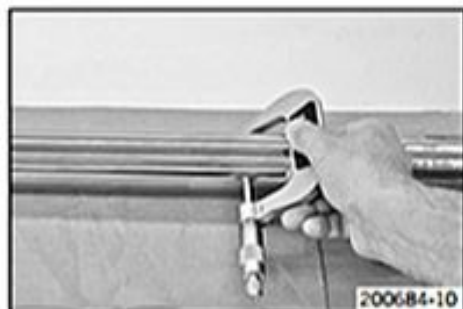
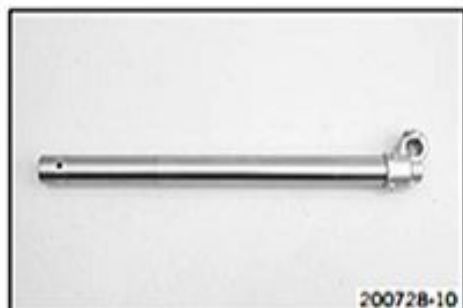

Condition

The fork legs have been disassembled.

- Check the inner tube and axle clamp for damage.
 - If there is damage:
 - Change the inner tube.

- Measure the outside diameter at multiple locations of the inner tube.

Outside diameter of inner tube	47.975... 48.005 mm (1.88878... 1.88996 in)
--------------------------------	---

- If the measured value is smaller than the specified value:
 - Change the inner tube.

- Measure the run-out of the inner tube.

Inner tube run-out	≤ 0.20 mm (≤ 0.0079 in)
--------------------	-------------------------

- If the measured value is larger than the specified value:
 - Change the inner tube.

- Measure the inside diameter at multiple locations of the outer tube.

Inside diameter of outer tube	≤ 49.20 mm (≤ 1.937 in)
-------------------------------	-------------------------

- If the measured value is larger than the specified value:
 - Change the outer tube.
- Check the outer tube for damage.
 - If there is damage:
 - Change the outer tube.



- Check the surface of the sliding bushings.
 - If the bronze-colored layer **A** under sliding layer **B** is visible or the surface is rough:
 - Change the sliding bushings.

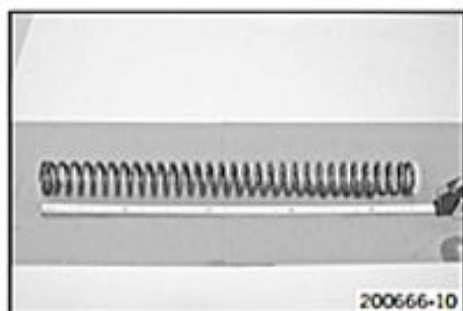

- Check the spring length.

Guideline

Spring length with preload spacer(s)	480 mm (18.9 in)
--------------------------------------	------------------

- If the measured value is larger than the specified value:
 - Reduce the thickness of the preload spacers.
- If the measured value is smaller than the specified value:
 - Increase the thickness of the preload spacers.

6.11.10 Assembling the seal ring retainer

i Info
The steps are identical for both fork legs.

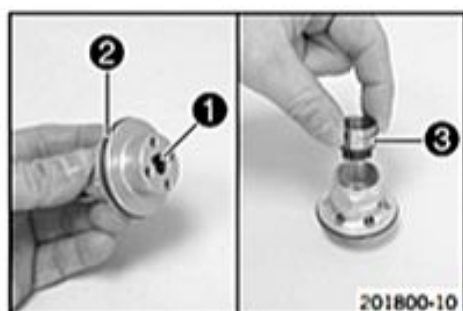

- Mount and grease seal ring **1**.
Lubricant (T158) (☞ p. 260)
- Mount and grease O-ring **2**.
Lubricant (T158) (☞ p. 260)
- Position pilot bushing support **3**.

6.11.11 Assembling the hydrostop unit

i Info
The steps are identical for both fork legs.

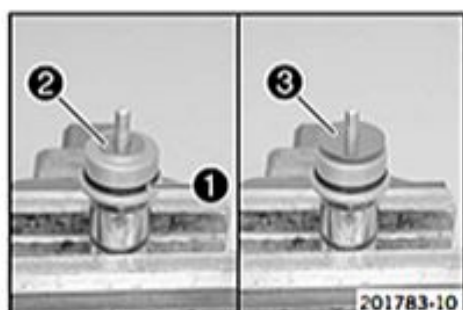

- Mount and grease O-ring **1**.
Lubricant (T158) (☞ p. 260)
- Mount washer **2**.
- Mount shim stack **3** with the smaller washers facing downward.

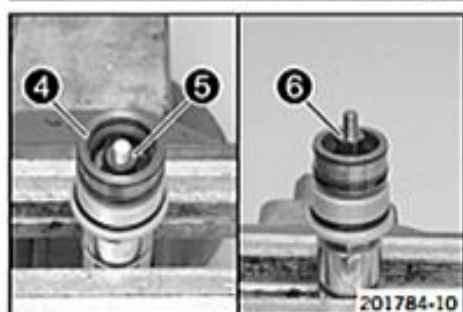

- Mount the new O-ring on hub **4**.
- Mount the hub with washers **5**.

i Info
It is possible that only one or no washer is present.

- Mount and tighten adapter **6**.

Guideline

Hydrostop unit adapter	M6x0.5	7 Nm (5.2 lbf ft)
------------------------	--------	-------------------

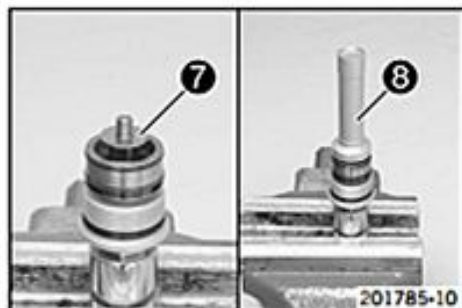

- Mount shim stack **7** with the smaller washers facing downward.
- Mount and tighten sleeve **8**.

Guideline

Hydrostop unit sleeve	M6x0.5	7 Nm (5.2 lbf ft)
-----------------------	--------	-------------------

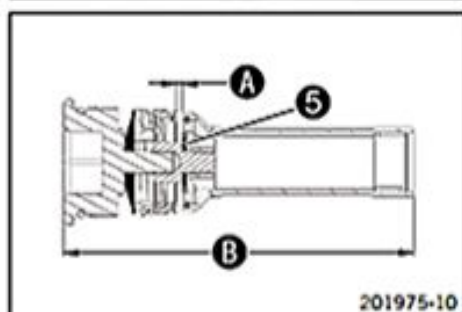

- Check distance **A** and total length **B** of the hydrostop.

Guideline

Hydrostop distance	≥ 1.5 mm (≥ 0.059 in)
Hydrostop length	108.5... 109.5 mm (4.272... 4.311 in)

- If the dimensions are out of tolerance:
 - Add or remove washers **5**.

6.11.12 Assembling the piston rod



Info

The steps are identical for both fork legs, except for the hydrostop needle and valve.

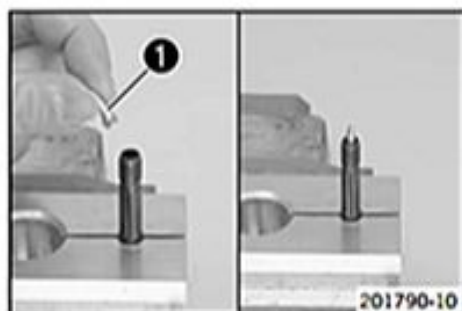

- Degrease the piston rod.
- Clamp the piston rod with the special tool.

Clamping stand (T14049S) (☞ p. 275)

- Lubricate the O-ring. Mount valve needle **1** in the piston rod.

Lubricant (T158) (☞ p. 260)

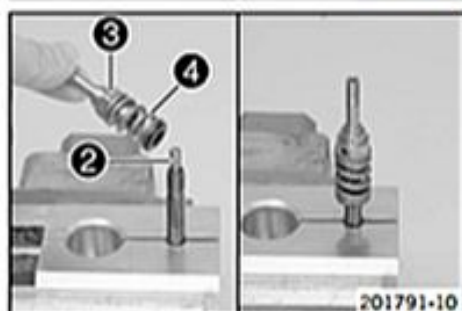

- Mount spring **2**.
- Mount and tighten adapter **3** with spring **4** and washer.

Guideline

Adapter of piston rod	M6x0.5	12 Nm (8.9 lbf ft)
-----------------------	--------	--------------------

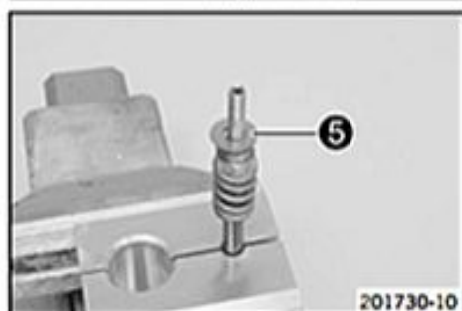

- Position the spring.
- Mount the compression shim stack **5** with the smaller washers facing downward.

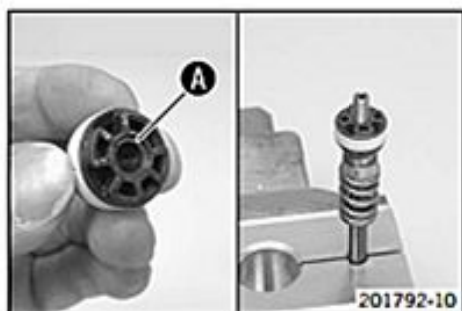

- Grind the piston on both sides on a surfacing plate using 1200 grit sandpaper.
- Clean the piston.
- Lubricate the piston ring.

Fork oil (SAE 4) (48601166S1) (☞ p. 258)

- Mount the piston with chamfer **A** facing down.

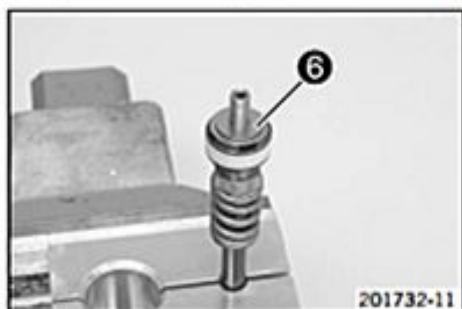

- Mount the rebound shim stack **6** with the smaller washers facing upward.

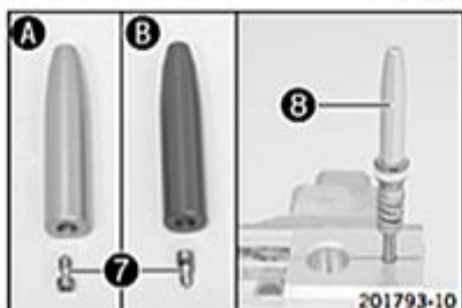

- Press the piston downward against the spring.
✓ The piston should not squeeze the shims.
- Position valve **7** in the hydrostop needle **8**. Mount and tighten the hydrostop needle.

Guideline

Hydrostop needle on piston rod	M6x0.5	7 Nm (5.2 lbf ft)
--------------------------------	--------	-------------------

Info

- A** - silver hydrostop needle on compression damping side.
- B** - red hydrostop needle on rebound damping side.

- Unclamp the piston rod.

6.11.13 Assembling the cartridge

Info
The steps are identical for both fork legs.

Preparatory work

- Assemble the seal ring retainer. (☞ p. 61)
- Assemble the piston rod. (☞ p. 62)

Main work

- Mount and grease seal rings **1** and O-ring **2**.

Lubricant (T158) (☞ p. 260)

- Mount and lubricate pilot bushings **3**.

Fork oil (SAE 4) (48601166S1) (☞ p. 258)

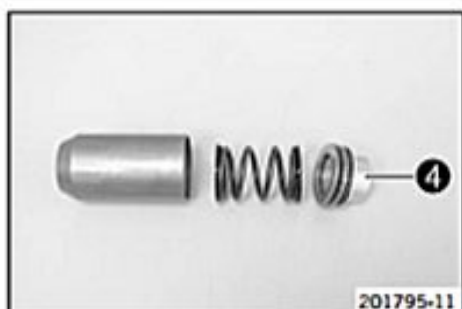
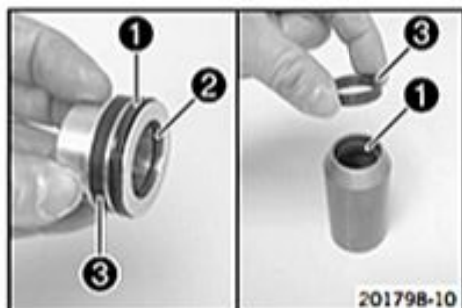

- Check the length of the reservoir spring.

Guideline

Reservoir spring length with preload spacer	46 mm (1.81 in)
---	-----------------

- If the length is out of tolerance:
 - Correct the preload spacers.
- Position the spring with the preload spacers in the reservoir.

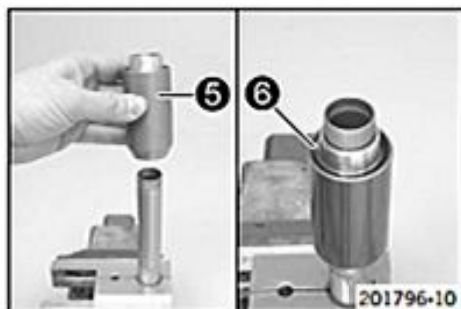

- Position sleeve **4** in the reservoir.
- Clamp the tube of the cartridge into a vise.

Clamping stand (T14049S) (☛ p. 275)

- Slide reservoir **5** onto the tube.

Info

Hold the sleeve in the reservoir to prevent it from sliding out.

- Mount lock ring **6**.

- Mount seal ring retainer **7** with the washer and tighten.

Guideline

Seal ring retainer	M23.5x0.75	46 Nm (33.9 lbf ft)	Loctite® 2701™
--------------------	------------	------------------------	----------------

- Unclamp the cartridge.



- Slide piston rod **8** into the cartridge.

Info

Ensure that the piston ring is seated correctly.

- Mount spring seat **9**.



- Degrease piston rod **8** and clamp in the vise.

Clamping stand (T14049S) (☛ p. 275)

- Screw spring guide **10** all the way on.

Info

The nut must be firmly tightened against the stop by hand. Do not use a tool.

- Mount adjusting tube **11**.

- Unclamp the piston rod. Mount the preload spacer(s).

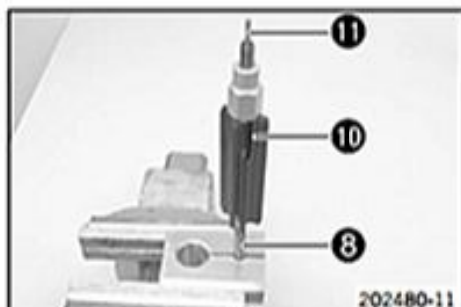

6.11.14 Assembling the fork legs

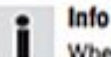
Info

When assembling, ensure that the right cartridge is mounted in the corresponding inner tube and the right adjuster is mounted on the corresponding screw cap.

Compression damping side – screw cap with mark **COMP**, brake caliper holder, white adjuster.

Rebound damping side – screw cap with mark **REB**, no brake caliper holder, red adjuster.

Preparatory work

- Assemble the hydrostop unit. (☛ p. 61)

Main work

- Clamp the inner tube with the axle clamp.

Guideline

Use soft jaws.

- Mount special tool.

Protecting sleeve (T1401) (☛ p. 272)



- Lubricate and mount dust boot ①.

Lubricant (T511) (☛ p. 260)



Info

Always change the dust boot, seal ring, lock ring and support ring. Mount the sealing lip with the spring expander facing downward.

- Slide on lock ring ②.
- Lubricate and slide on seal ring ③.

Lubricant (T511) (☛ p. 260)



Info

Mount with the sealing lip facing down and the open side facing up.

- Slide on support ring ④.
- Remove the special tool.
- Grind the edges of the sliding bushings with sandpaper grit 600, clean the bushings and lubricate them.

Fork oil (SAE 4) (48601166S1) (☛ p. 258)



- Slide on the lower sliding bushing ⑤.
- Mount the upper sliding bushing ⑥.



Info

Do not use a tool; pull the ends apart slightly by hand.



- Warm the outer tube in area A of the lower sliding bushing.

Guideline

50 °C (122 °F)

- Slide the outer tube onto the inner tube.
- Hold the lower sliding bushing with the longer section of the special tool.

Mounting tool (T14040S) (☛ p. 275)

- Push the sliding bushing all the way into the outer tube.



- Position the support ring.
- Hold the seal ring with the shorter section of the special tool.

Mounting tool (T14040S) (☛ p. 275)

- Push the seal ring and support ring all the way into the outer tube.

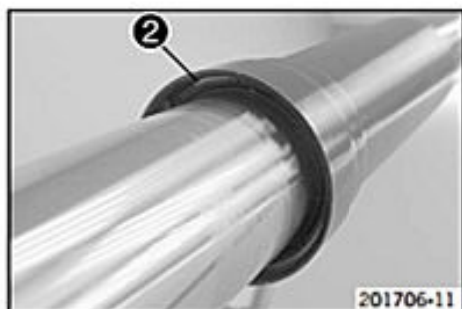

- Mount lock ring ②.



Info

The lock ring must engage audibly.

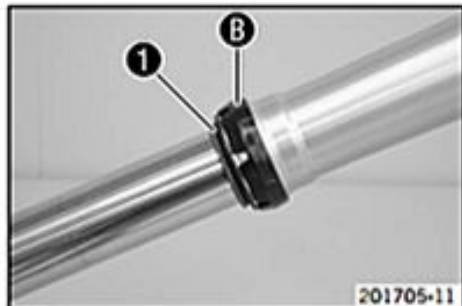

- Mount dust boot ①.
- Mount fork protection ring B.



- Lubricate the O-ring. Slide the cartridge all the way into the fork leg.

Fork oil (SAE 4) (48601166S1) (☛ p. 258)
--



- Turn the fork. Have the entire filling quantity of fork oil available.

Oil capacity per fork leg	680 ml (22.99 fl. oz.)	Fork oil (SAE 4) (48601166S1) (☛ p. 258)
---------------------------	------------------------	--

- Add some of the fork oil while pulling out and pushing in the piston rod numerous times.

Guideline

Fork oil quantity	510 ml (17.24 fl. oz.)
-------------------	------------------------

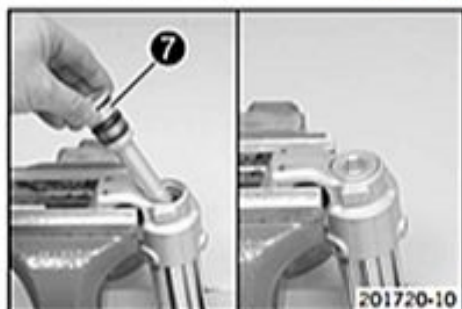

- Mount and tighten hydrostop unit ⑦.

Guideline

Hydrostop unit	M30x1	40 Nm (29.5 lbf ft)
----------------	-------	---------------------



- Clamp the fork vertically.
- Add the remaining quantity of fork oil.

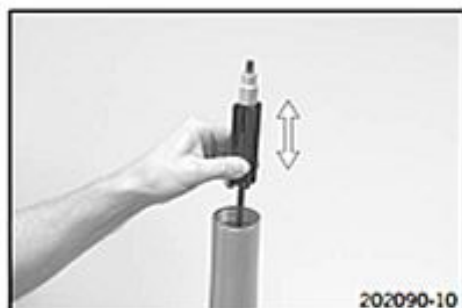

- Pull out the piston rod and push it back in numerous times while pressing it to one side slightly.
 - ✓ Air bubbles emerge and the cartridge is bled.
- Keep bleeding until no more air bubbles emerge.
 - ✓ The piston rod moves out automatically to the middle of the total stroke distance.

i Info

When fully bled, the correct air chamber length is achieved automatically.

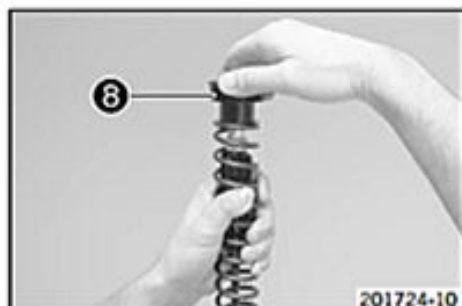

- Position spring.
- Pull the spring down. Mount screw cap **8**.

i Info

When assembling, ensure that the screw caps are correctly mounted according to the hydrostop needles.

Rebound damping side – red hydrostop needle, screw cap with mark **REB**.
Compression damping side – silver hydrostop needle, screw cap with mark **COMP**.



- Pull the spring down. Mount the open end wrench on the hexagonal part.
- Hold the open end wrench. Tighten screw cap **8**.

Guideline

Screw cap on piston rod	M8x0.75	18 Nm (13.3 lbf ft)
Special socket (T14047) (☛ p. 275)		



- Push the outer tube up.
- Clamp the outer tube in the area of the lower triple clamp.

Clamping stand (T1403S) (☛ p. 275)

- Tighten screw cap **8**.

Guideline

Cartridge on outer tube	M51x1.5	40 Nm (29.5 lbf ft)
Special socket (T14047) (☛ p. 275)		

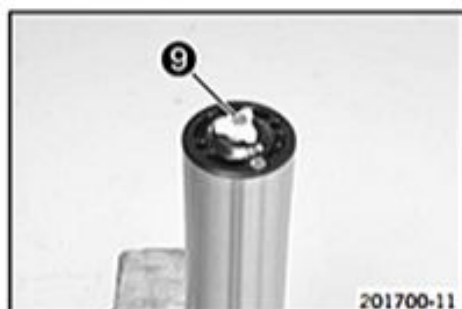

- Mount the adjuster. Mount and tighten screw **9**.

Guideline

Screw, adjuster	M4x0.5	2.5 Nm (1.84 lbf ft)
-----------------	--------	-------------------------

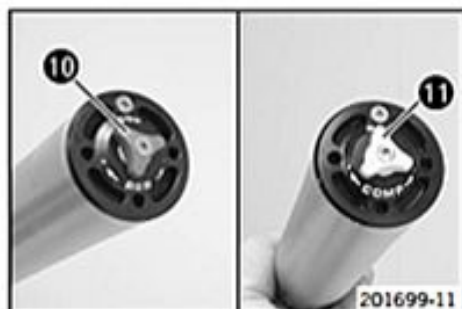

Alternative 1

- Turn the adjuster of compression damping **10** (mark **COMP**) and the adjuster of rebound damping **11** (mark **REB**) all the way clockwise.

Guideline

Rebound damping	
Comfort	17 clicks
Standard	15 clicks
Sport	13 clicks
Compression damping	
Comfort	17 clicks
Standard	15 clicks
Sport	13 clicks

- Turn counterclockwise by the number of clicks corresponding to the fork type.

Alternative 2

**Warning**

Danger of accidents Modifications to the suspension settings can seriously alter the vehicle's ride behavior.

- Extreme modifications to the adjustment of the suspension components can cause a serious deterioration in the handling characteristics and overload some components.
- Only make adjustments within the recommended range.
- After making adjustments, ride slowly at first to get the feel of the new ride behavior.

- Set the adjusters to the positions determined upon removal.

6.12 Greasing the steering head bearing

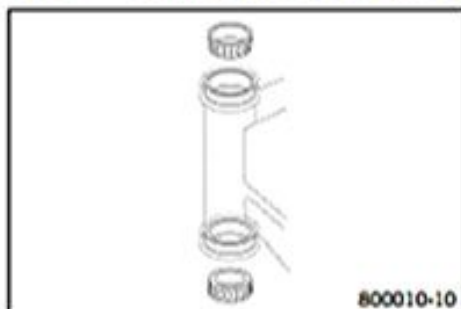

- Remove the lower triple clamp. (☞ p. 68)
- Install the lower triple clamp. (☞ p. 69)

6.13 Removing the lower triple clamp

Preparatory work

- Raise the motorcycle with the lift stand. (☞ p. 10)
- Remove the front wheel. (☞ p. 119)
- Remove the fork legs. (☞ p. 14)
- Remove the start number plate. (☞ p. 116)
- Remove the front fender. (☞ p. 116)
- Remove the handlebar cushion.

Main work

- Remove screw ①.
- Remove screw ②.
- Take off the top triple clamp with the handlebar and set it aside.

**Info**

Protect the motorcycle and its attachments against damage by covering them.
Do not bend the cables and lines.

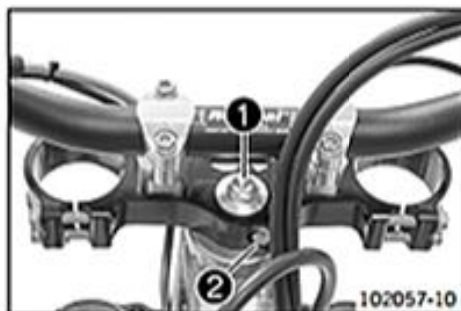



- Remove O-ring ③. Remove protective ring ④.
- Take out the lower triple clamp with the steering stem.
- Take out the upper steering head bearing.

6.14 Installing the lower triple clamp

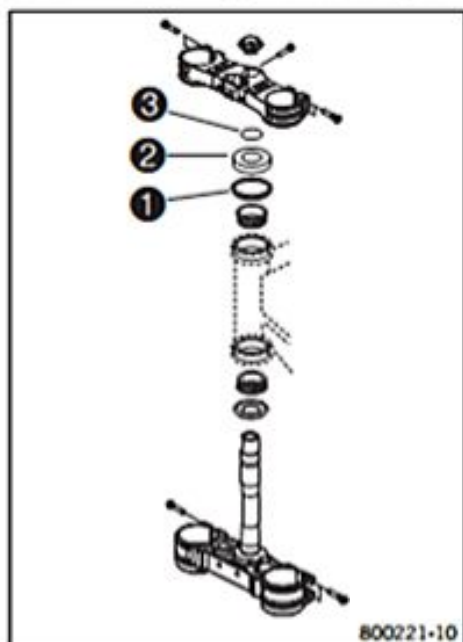

Main work

- Clean the bearing and sealing elements, check for damage, and grease.

High viscosity grease (☛ p. 260)

- Insert the lower triple clamp with the steering stem. Mount the upper steering head bearing.
- Check whether the upper steering head seal ① is correctly positioned.
- Slide on protective ring ② and O-ring ③.

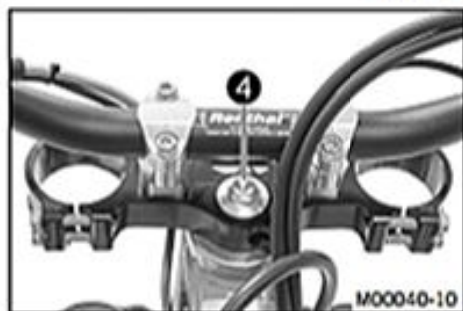

- Position the upper triple clamp with the handlebar.
- Mount screw ④ but do not tighten yet.

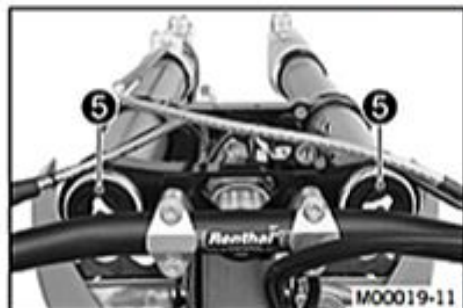

(SX-F EU)

- Position the fork legs.
 - ✓ Bleeder screws ⑤ face forward.



Info

Grooves are milled into the side of the upper end of the fork legs. The second milled groove (from the top) must be flush with the top edge of the upper triple clamp.



(SX-F USA, XC-F)

- Position the fork legs.
 - ✓ Bleeder screws ⑤ face forward.

i Info

The rebound damping is located in the right fork leg (red adjusting screw). The compression damping is located in the left fork leg (white adjusting screw).

Grooves are milled into the side of the upper end of the fork legs. The second milled groove (from the top) must be flush with the top edge of the upper triple clamp.



- Tighten screws 6.

Guideline

Screw, bottom triple clamp	M8	12 Nm (8.9 lbf ft)
----------------------------	----	--------------------

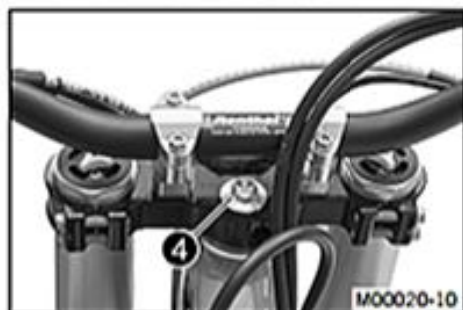

- Tighten screw 4.

Guideline

Screw, top steering head	M20x1.5	12 Nm (8.9 lbf ft)
--------------------------	---------	--------------------



- Mount and tighten screw 7.

Guideline

Screw, top steering stem	M8	17 Nm (12.5 lbf ft)	Loctite® 243™
--------------------------	----	------------------------	---------------

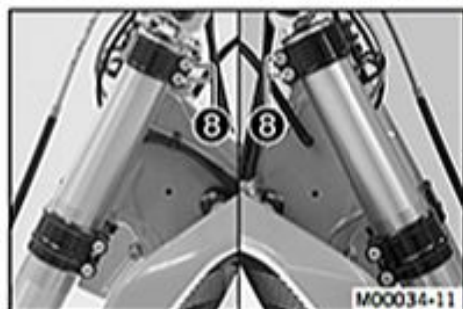

- Using a plastic hammer, tap lightly on the upper triple clamp to avoid strains.

- Tighten screws 8.

Guideline

Screw, top triple clamp	M8	17 Nm (12.5 lbf ft)
-------------------------	----	------------------------

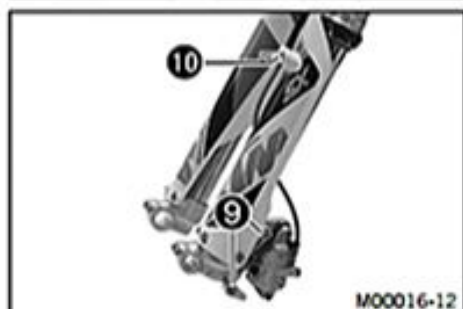

- Position the brake caliper. Mount and tighten screws 9.

Guideline

Screw, front brake caliper	M8	25 Nm (18.4 lbf ft)	Loctite® 243™
----------------------------	----	------------------------	---------------

- Position the brake line and clamp. Mount and tighten screws 10.

Finishing work

- Install the front fender. (☛ p. 116)

- Mount the handlebar cushion.
- Install the start number plate. (☞ p. 117)
- Install the front wheel. (☞ p. 120)
- Check that the wiring harness, throttle cables and brake and clutch lines can move freely and are routed correctly.
- Check the steering head bearing play. (☞ p. 71)
- Remove the motorcycle from the lift stand. (☞ p. 10)

6.15 Checking the steering head bearing play



Warning

Danger of accidents Unstable vehicle handling from incorrect steering head bearing play.

- Adjust the steering head bearing play without delay.



Info

If the bike is ridden with play in the steering head bearing, the bearing and the bearing seats in the frame can become damaged over time.

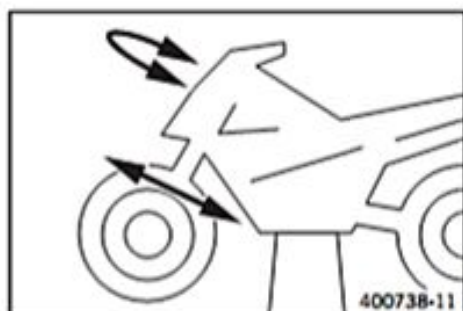

Preparatory work

- Raise the motorcycle with the lift stand. (☞ p. 10)

Main work

- Move the handlebar to the straight-ahead position. Move the fork legs to and fro in the direction of travel.

No play should be noticeable in the steering head bearing.

- If there is noticeable play present:
 - Adjust the play of the steering head bearing. (☞ p. 71)
- Move the handlebar to and fro over the entire steering range.

The handlebar must be able to move easily over the entire steering range. No resting locations should be noticeable.

- If click positions are noticeable:
 - Adjust the play of the steering head bearing. (☞ p. 71)
 - Check the steering head bearing and change if necessary.

Finishing work

- Remove the motorcycle from the lift stand. (☞ p. 10)

6.16 Adjusting the play of the steering head bearing

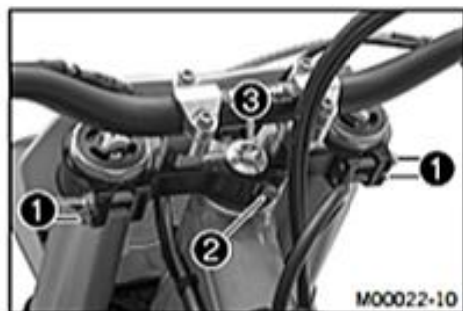

Preparatory work

- Raise the motorcycle with the lift stand. (☞ p. 10)
- Remove the handlebar cushion.

Main work

- Loosen screw ①. Remove screw ②.
- Loosen and retighten screw ③.

Guideline

Screw, top steering head	M20x1.5	12 Nm (8.9 lbf ft)
--------------------------	---------	--------------------

- Using a plastic hammer, tap lightly on the upper triple clamp to avoid strains.
- Fully tighten screws ①.

Guideline

Screw, top triple clamp	M8	17 Nm (12.5 lbf ft)
-------------------------	----	---------------------

- Mount and tighten screw ②.

Guideline

Screw, top steering stem	M8	17 Nm (12.5 lbf ft)	Loctite® 243™
--------------------------	----	---------------------	---------------

- Check the steering head bearing play. (☞ p. 71)

Finishing work

- Mount the handlebar cushion.
- Remove the motorcycle from the lift stand. (☛ p. 10)

7.1 Handlebar position

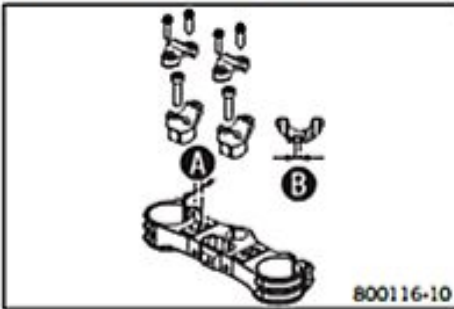

On the upper triple clamp, there are two holes at a distance of **A** to each other.

Hole distance A	15 mm (0.59 in)
-----------------	-----------------

The holes on the handlebar support are placed at a distance of **B** from the center.

Hole distance B	3.5 mm (0.138 in)
-----------------	-------------------

The handlebar can be mounted in four different positions. In this way, the handlebar can be mounted in the position that is most comfortable for the rider.

7.2 Adjusting the handlebar position

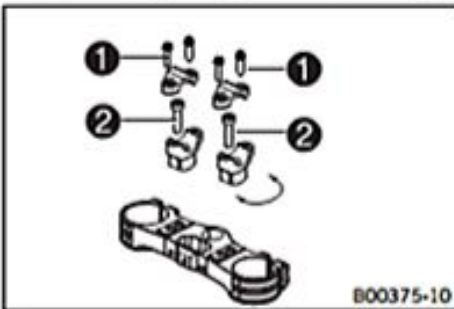

- Remove screws **1**. Take off the handlebar clamps. Take off the handlebar and lay it to one side.

i Info
Protect the components against damage by covering them.
Do not bend the cables and lines.

- Remove screws **2**. Remove the handlebar supports.
- Place the handlebar supports in the required position. Mount and tighten screws **2**.

Guideline

Screw, handlebar support	M10	40 Nm (29.5 lbf ft)	Loctite® 243™
--------------------------	-----	------------------------	---------------

i Info
Position the left and right handlebar supports evenly.

- Position the handlebar.

i Info
Make sure the cables and wiring are positioned correctly.

- Position the handlebar clamps. Mount and tighten screws **1** evenly.

Guideline

Screw, handlebar clamp	M8	20 Nm (14.8 lbf ft)
------------------------	----	------------------------

7.3 Adjusting the basic position of the clutch lever



- Adjust the basic setting of the clutch lever to your hand size by turning adjusting screw **1**.

i Info
Turn the adjusting screw counterclockwise to decrease the distance between the clutch lever and the handlebar.
Turn the adjusting screw clockwise to increase the distance between the clutch lever and the handlebar.
The range of adjustment is limited.
Turn the adjusting screw by hand only, and do not apply any force.
Do not make any adjustments while riding!

7.4 Checking the throttle cable routing

**Preparatory work**

- Remove the seat. (☛ p. 107)
- Remove the fuel tank. (☛ p. 107)

Main work

- Check the throttle cable routing.

Both throttle cables must be routed to the throttle valve body side by side behind the handlebars and above the fuel tank bracket.

- If the throttle cable is not routed as specified:
 - Correct the throttle cable routing.

Finishing work

- Install the fuel tank. (☛ p. 108)
- Mount the seat. (☛ p. 107)

7.5 Checking the play in the throttle cable

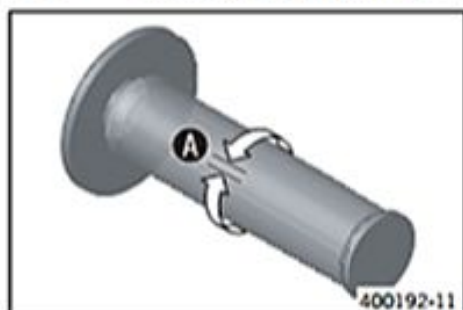

- Check the throttle grip for smooth operation.
- Move the handlebar to the straight-ahead position. Turn the throttle grip back and forth slightly and determine the play in throttle cable **A**.

Play in throttle cable	3... 5 mm (0.12... 0.2 in)
------------------------	----------------------------

- If the throttle cable play does not meet specifications:
 - Adjust the play in the throttle cable. (☛ p. 75)

**Danger**

Danger of poisoning Exhaust gases are toxic and inhaling them may result in unconsciousness and/or death.

- When running the engine, always make sure there is sufficient ventilation, and do not start or run the engine in an enclosed space without an effective exhaust extraction system.

- Start the engine and let it run idle. Move the handlebar to and fro over the entire steering range.

The idle speed must not change.

- If the idle speed changes:
 - Adjust the play in the throttle cable. (☛ p. 75)

7.6 Adjusting the play in the throttle cable

**Preparatory work**

- Remove the seat. (☞ p. 107)
- Remove the fuel tank. (☞ p. 107)
- Check the throttle cable routing. (☞ p. 74)

Main work

- Move the handlebar to the straight-ahead position.
- Push back sleeves ①.
- Loosen nut ②. Turn adjusting screw ③ in as far as possible.
- Loosen nut ④. Turn adjusting screw ⑤ so that there is play in the throttle cable at the throttle grip.

Guideline

Play in throttle cable	3... 5 mm (0.12... 0.2 in)
------------------------	----------------------------

- Tighten nut ④.
- Press and hold the throttle grip in the closed setting. Turn adjusting screw ③ out until there is no play in the throttle cable ⑥.
- Tighten nut ②.
- Push sleeves ① on. Check the throttle grip for smooth operation.

Finishing work

- Check the play in the throttle cable. (☞ p. 74)
- Install the fuel tank. (☞ p. 108)
- Mount the seat. (☞ p. 107)

8.1 Adjusting the high-speed compression damping of the shock absorber

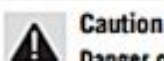
Caution

Danger of accidents Disassembly of pressurized parts can lead to injury.

- The shock absorber is filled with high density nitrogen. Adhere to the description provided.

Info

The high-speed setting can be seen during the fast compression of the shock absorber.



- Turn adjusting screw **1** all the way clockwise with a socket wrench.

Info

Do not loosen fitting **2**!

- Turn counterclockwise by the number of turns corresponding to the shock absorber type.

Guideline

Compression damping, high-speed (SX-F EU)	
Comfort	2.5 turns
Standard	2 turns
Sport	1.5 turns
Compression damping, high-speed (SX-F USA)	
Comfort	2.5 turns
Standard	2 turns
Sport	1.5 turns
Compression damping, high-speed (XC-F)	
Comfort	2.5 turns
Standard	2 turns
Sport	1.5 turns

Info

Turn clockwise to increase damping; turn counterclockwise to reduce damping.

8.2 Adjusting the low-speed compression damping of the shock absorber

Caution

Danger of accidents Disassembly of pressurized parts can lead to injury.

- The shock absorber is filled with high density nitrogen. Adhere to the description provided.

Info

The low-speed setting can be seen during the slow to normal compression of the shock absorber.



- Turn adjusting screw **1** clockwise with a screwdriver up to the last perceptible click.

Info

Do not loosen fitting **2**!

- Turn counterclockwise by the number of clicks corresponding to the shock absorber type.

Guideline

Compression damping, low-speed (SX-F EU)	
Comfort	17 clicks
Standard	15 clicks
Sport	13 clicks
Compression damping, low-speed (SX-F USA)	
Comfort	17 clicks
Standard	15 clicks
Sport	13 clicks
Compression damping, low-speed (XC-F)	
Comfort	17 clicks
Standard	15 clicks
Sport	13 clicks

Info
Turn clockwise to increase damping; turn counterclockwise to reduce damping.

8.3 Adjusting the rebound damping of the shock absorber

Caution
Danger of accidents Disassembly of pressurized parts can lead to injury.

- The shock absorber is filled with high density nitrogen. Adhere to the description provided.



- Turn adjusting screw ① clockwise up to the last perceptible click.
- Turn counterclockwise by the number of clicks corresponding to the shock absorber type.

Guideline

Rebound damping (SX-F EU)	
Comfort	17 clicks
Standard	15 clicks
Sport	13 clicks
Rebound damping (SX-F USA)	
Comfort	17 clicks
Standard	15 clicks
Sport	13 clicks
Rebound damping (XC-F)	
Comfort	17 clicks
Standard	15 clicks
Sport	13 clicks

Info
Turn clockwise to increase damping; turn counterclockwise to reduce damping.

8.4 Measuring rear wheel sag unloaded

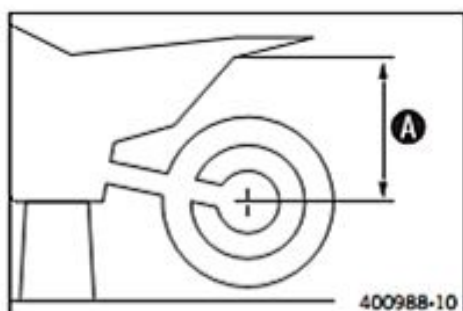

Preparatory work

- Raise the motorcycle with the lift stand. (☛ p. 10)

Main work

- Measure the vertical distance between the rear axle and a fixed point such as a marking on the side cover.
- Note down the value as dimension **A**.

Finishing work

- Remove the motorcycle from the lift stand. (☛ p. 10)

8.5 Checking the static sag of the shock absorber

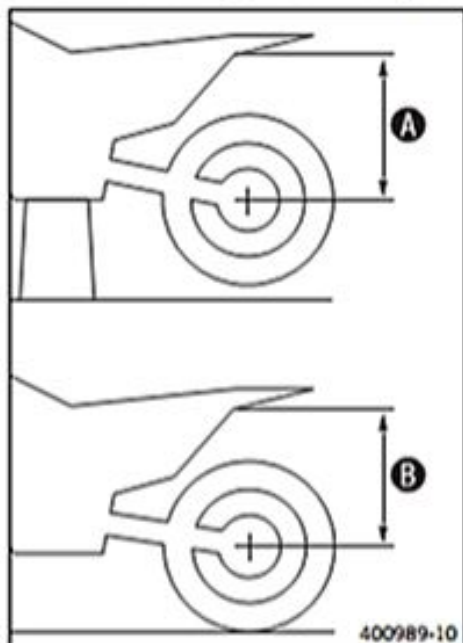

- Measure distance **A** of rear wheel unloaded. (☛ p. 78)
- Hold the motorcycle upright with the aid of an assistant.
- Measure the distance between the rear axle and the fixed point again.
- Note down the value as dimension **B**.



Info

The static sag is the difference between measurements **A** and **B**.

- Check the static sag.

Static sag (SX-F EU)	30 mm (1.18 in)
Static sag (SX-F USA)	30 mm (1.18 in)
Static sag (XC-F)	30 mm (1.18 in)

- If the static sag is less or more than the specified value:
 - Adjust the spring preload of the shock absorber. (☛ p. 79)

8.6 Checking the riding sag of the shock absorber

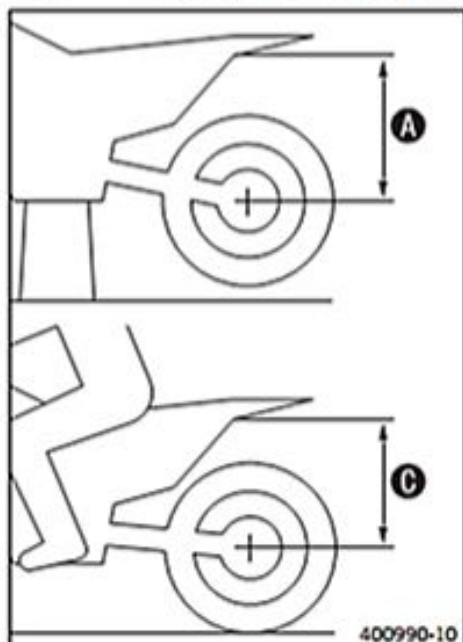

- Measure distance **A** of rear wheel unloaded. (☛ p. 78)
- With another person holding the motorcycle, the rider, wearing full protective clothing, sits on the seat in a normal sitting position (feet on footrests) and bounces up and down a few times.
 - ✓ The rear wheel suspension levels out.
- Another person now remeasures the distance between the rear axle and a fixed point.
- Note down the value as dimension **C**.



Info

The riding sag is the difference between measurements **A** and **C**.

- Check the riding sag.

Riding sag (SX-F EU)	100 mm (3.94 in)
Riding sag (SX-F USA)	100 mm (3.94 in)
Riding sag (XC-F)	100 mm (3.94 in)

- If the riding sag differs from the specified measurement:
 - Adjust the riding sag. (☛ p. 79)

8.7 Adjusting the spring preload of the shock absorber

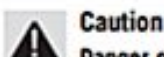
**Caution**

Danger of accidents Disassembly of pressurized parts can lead to injury.

- The shock absorber is filled with high density nitrogen. Adhere to the description provided.

**Info**

Before changing the spring preload, make a note of the present setting, e.g., by measuring the length of the spring.

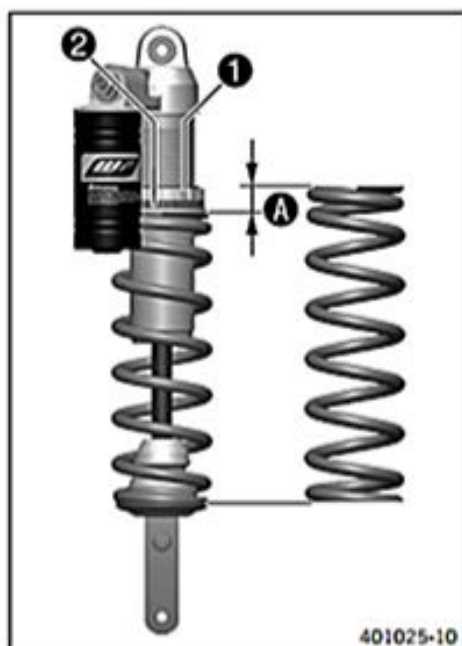
**Preparatory work**

- Raise the motorcycle with the lift stand. (☛ p. 10)
- Remove the manifold. (☛ p. 100)
- Remove the shock absorber. (☛ p. 80)
- After removing the shock absorber, clean it thoroughly.

Main work

- Loosen screw ①.
- Turn adjusting ring ② until the spring is no longer under tension.

Hook wrench (T106S) (☛ p. 270)

- Measure the overall spring length while the spring is not under tension.
- Tighten the spring by turning adjusting ring ② to measurement A.

Guideline

Spring preload (SX-F EU)	8 mm (0.31 in)
Spring preload (SX-F USA)	8 mm (0.31 in)
Spring preload (XC-F)	8 mm (0.31 in)

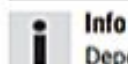
**Info**

Depending on the static sag and/or the riding sag, it may be necessary to increase or decrease the spring preload.

- Tighten screw ①.

Guideline

Screw, shock absorber adjusting ring	M5	5 Nm (3.7 lbf ft)
--------------------------------------	----	-------------------

Finishing work

- Install the shock absorber. (☛ p. 81)
- Install the manifold. (☛ p. 100)
- Remove the motorcycle from the lift stand. (☛ p. 10)

8.8 Adjusting the riding sag

Preparatory work

- Raise the motorcycle with the lift stand. (☛ p. 10)
- Remove the manifold. (☛ p. 100)
- Remove the shock absorber. (☛ p. 80)
- After removing the shock absorber, clean it thoroughly.

Main work

- Choose and mount a suitable spring.

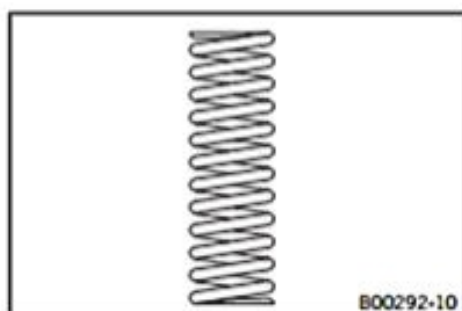

Guideline

Spring rate (SX-F EU)	
Weight of rider: 65... 75 kg (143... 165 lb.)	54 N/mm (308 lb/in)
Weight of rider: 75... 85 kg (165... 187 lb.)	57 N/mm (325 lb/in)
Weight of rider: 85... 95 kg (187... 209 lb.)	60 N/mm (343 lb/in)
Spring rate (SX-F USA)	
Weight of rider: 65... 75 kg (143... 165 lb.)	54 N/mm (308 lb/in)
Weight of rider: 75... 85 kg (165... 187 lb.)	57 N/mm (325 lb/in)
Weight of rider: 85... 95 kg (187... 209 lb.)	60 N/mm (343 lb/in)
Spring rate (XC-F)	
Weight of rider: 65... 75 kg (143... 165 lb.)	54 N/mm (308 lb/in)
Weight of rider: 75... 85 kg (165... 187 lb.)	57 N/mm (325 lb/in)
Weight of rider: 85... 95 kg (187... 209 lb.)	60 N/mm (343 lb/in)

Info
The spring rate is shown on the outside of the spring.

Finishing work

- Install the shock absorber. (☛ p. 81)
- Install the manifold. (☛ p. 100)
- Check the static sag of the shock absorber. (☛ p. 78)
- Check the riding sag of the shock absorber. (☛ p. 78)
- Adjust the rebound damping of the shock absorber. (☛ p. 77)
- Remove the motorcycle from the lift stand. (☛ p. 10)

8.9 Removing the shock absorber

Preparatory work

- Raise the motorcycle with the lift stand. (☛ p. 10)
- Remove the manifold. (☛ p. 100)

Main work

- Remove screw ①.
- Remove fitting ②.
- Press angle lever ③ toward the rear.
- Press linkage lever ④ downward.

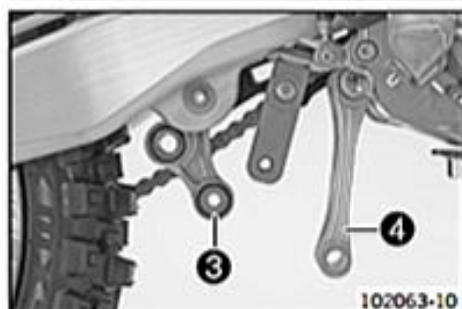
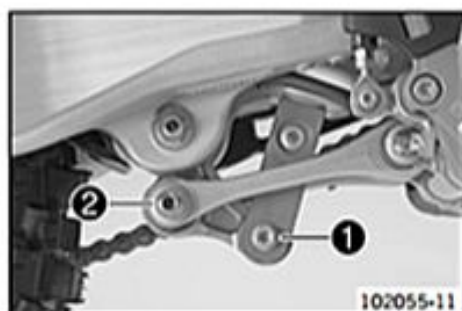



- Lift the swingarm.

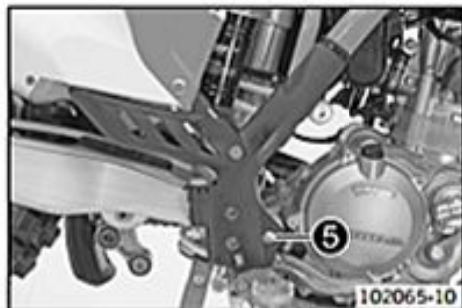

- Remove the cable binder of the frame protector.
- Remove screw 5.
- Remove the frame protector.

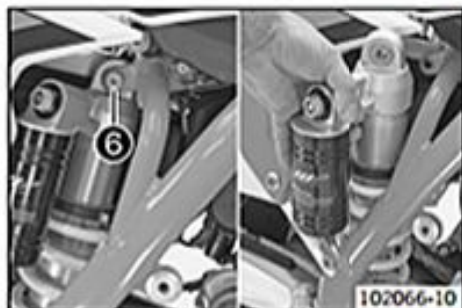

Info

Pay attention to the holding lugs.

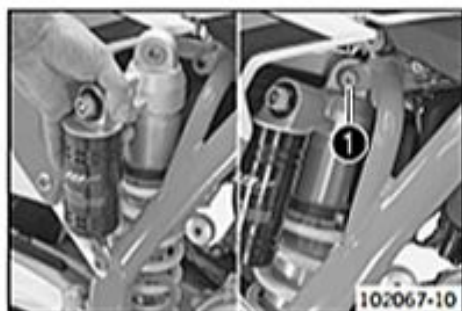

- Remove screw 6.
- Carefully remove the shock absorber upward out of the vehicle.

8.10 Installing the shock absorber

Main work

- From above, position the shock absorber carefully in the vehicle.
- Mount and tighten screw 1.

Guideline

Screw, top shock absorber	M10	60 Nm (44.3 lbf ft)	Loctite® 2701™
---------------------------	-----	------------------------	----------------



- Position the frame protector.

Info

Pay attention to the holding lugs.

- Mount and tighten screw 2.

Guideline

Screw, frame protector	M5	3 Nm (2.2 lbf ft)
------------------------	----	-------------------

- Attach the frame protector with a cable binder.
- Lower the swingarm.



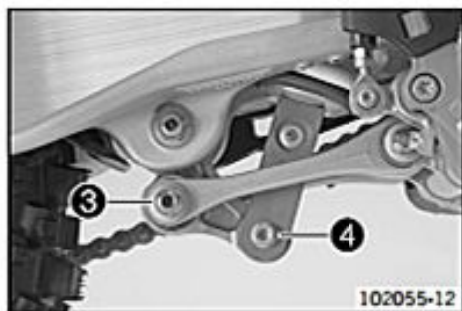

- Position the angle lever and linkage lever.
- Mount and tighten screw cap ③.

Guideline

Nut, linkage lever to angle lever	M14x1.5	80 Nm (59 lbf ft)
-----------------------------------	---------	-------------------

- Mount and tighten screw ④.

Guideline

Screw, bottom shock absorber	M10	60 Nm (44.3 lbf ft)	Loctite® 2701™
------------------------------	-----	---------------------	----------------

Finishing work

- Install the manifold. (☛ p. 100)
- Remove the motorcycle from the lift stand. (☛ p. 10)

8.11 Checking the shock absorber linkage

Preparatory work

- Raise the motorcycle with the lift stand. (☛ p. 10)

Main work

- Remove screw ①.
- Remove screw connection ②.

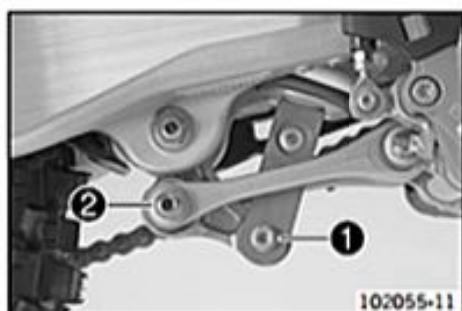

i Info

Raise the wheel slightly to make it easier to remove the screws.



- Remove screw connection ③.
- Take off the angle lever.

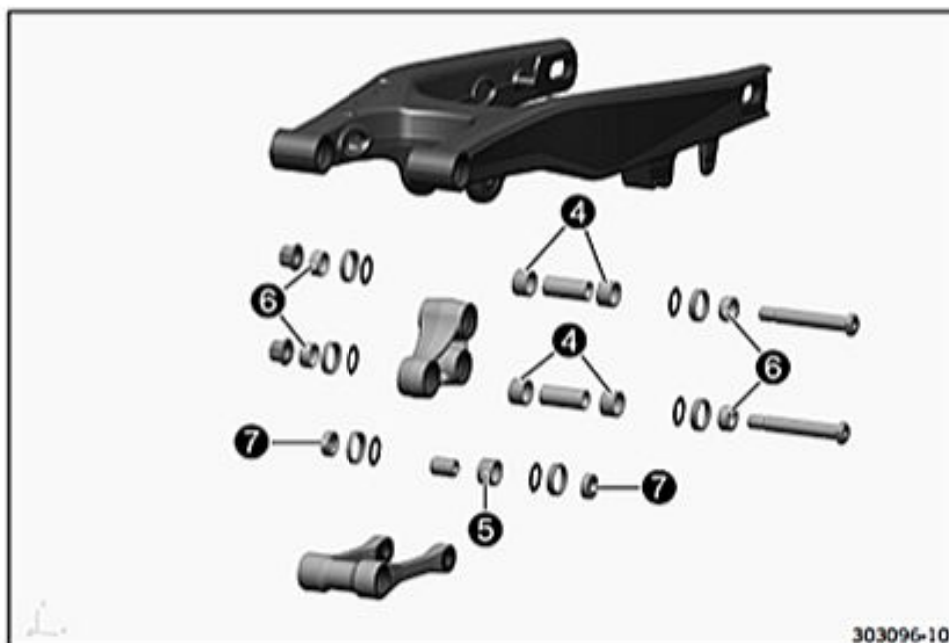

- Check needle bearing ④ and ⑤ for damage and wear.
 - If there is damage or wear:

- Change the needle bearing.
- Check spacers ⑥ and ⑦ for damage and wear.
 - If there is damage or wear:
 - Change the spacers.
- Check the shaft seal rings for damage and wear.
 - If there is damage or wear:
 - Change the shaft seal rings.

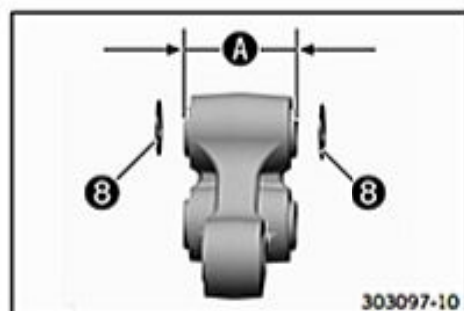

- Check dimension A.

54.91... 55.00 mm (2.1618... 2.1654 in)

- If dimension A is less than the specified value:
 - Add the corresponding spacing washers ⑧.



- Position the angle lever.
- Mount screw connection ③ but do not tighten yet.

Guideline

Nut, linkage lever on swingarm	M14x1.5	80 Nm (59 lbf ft)
--------------------------------	---------	-------------------



- Mount screw ① but do not tighten yet.

Guideline

Screw, bottom shock absorber	M10	60 Nm (44.3 lbf ft)	Loctite® 2701™
------------------------------	-----	---------------------	----------------



Info

Raise the wheel slightly to make it easier to mount the screw.



- Position the linkage lever.
- Mount and tighten fitting ②.

Guideline

Nut, linkage lever to angle lever	M14x1.5	80 Nm (59 lbf ft)
-----------------------------------	---------	-------------------



Info

Raise the wheel slightly to make it easier to mount the screw.

- Tighten screws ①.

Guideline

Screw, bottom shock absorber	M10	60 Nm (44.3 lbf ft)	Loctite® 2701™
------------------------------	-----	---------------------	----------------

- Tighten fitting ③.

Guideline

Nut, linkage lever on swingarm	M14x1.5	80 Nm (59 lbf ft)
--------------------------------	---------	-------------------

Finishing work

- Remove the motorcycle from the lift stand. (☛ p. 10)

8.12 Servicing the shock absorber



Caution

Danger of accidents Disassembly of pressurized parts can lead to injury.

- The shock absorber is filled with high density nitrogen. Adhere to the description provided.

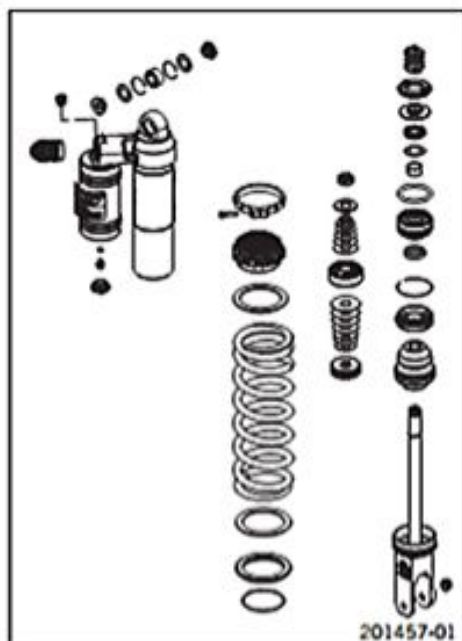

Condition

The shock absorber has been removed.

- Remove the spring. (☛ p. 84)
- Disassemble the damper. (☛ p. 85)
- Disassemble the piston rod. (☛ p. 86)
- Disassemble the seal ring retainer. (☛ p. 87)
- Check the damper. (☛ p. 88)
- Remove the heim joint. (☛ p. 89)
- Install the heim joint. (☛ p. 90)
- Assemble the seal ring retainer. (☛ p. 91)
- Assemble the piston rod. (☛ p. 91)
- Assemble the damper. (☛ p. 93)
- Install the spring. (☛ p. 98)

8.13 Removing the spring



Condition

The shock absorber has been removed.

- Clamp the shock absorber in the vise using soft jaws for protection.
- Measure and note spring length in its preloaded state.
- Loosen screw ①.
- Turn adjusting ring until the spring is no longer under tension.

Hook wrench (T106S) (☛ p. 270)

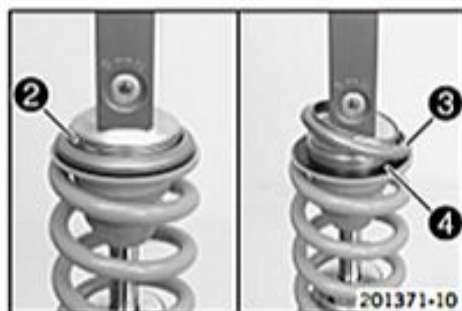

- Remove ring ②.
- Remove spring retainer ③ and intermediate washer ④.
- Remove the spring.

8.14 Disassembling the damper

Preparatory work

- Remove the spring. (☞ p. 84)

Main work

- Note down the current state of rebound damping ① and compression damping ②.
- Completely open the adjusters of the rebound and compression damping.

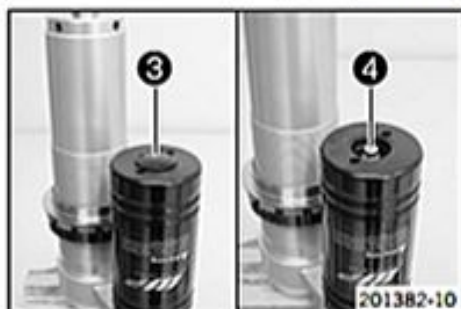

- Remove rubber cap ③ of the reservoir.
- Open screw ④ slowly.
- ✓ The pressurized nitrogen escapes.



- Remove locking cap ⑤.



- Press in seal ring retainer ⑥ using the special tool.

Disassembly tool (T1216) (☞ p. 272)



- Remove lock ring ⑦.



Info

Do not scratch the inner surface.



- Remove the piston rod.



- Remove adjusting ring 8 with the intermediate washer.
- Drain the oil.

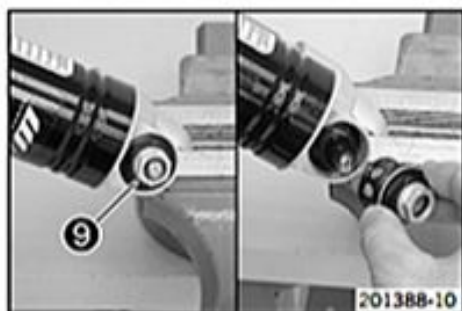

- Remove compression adjuster 9. Remove the spring and piston.

8.15 Disassembling the piston rod

Preparatory work

- Remove the spring. (☞ p. 84)
- Disassemble the damper. (☞ p. 85)

Main work

- Clamp the piston rod with the fork in a vise.

Guideline

Use soft jaws.



- Remove nut 1.
- Remove washer 2.



- Remove rebound shim stack 3.



Info

Place the rebound shim stack onto a screwdriver and set it down as a unit.

- Remove piston 4.



- Remove compression shim stack ⑤.

Info

Place the compression shim stack onto a screwdriver and set it down as a unit.

- Remove rebound washer ⑥.



- Remove seal ring retainer ⑦.
- Remove locking cap ⑧ and rubber buffer ⑨.

8.16 Disassembling the seal ring retainer

Preparatory work

- Remove the spring. (☛ p. 84)
- Disassemble the damper. (☛ p. 85)
- Disassemble the piston rod. (☛ p. 86)

Main work

- Remove spring ①.
- Remove O-ring ②.
- Remove rebound rubber ③.

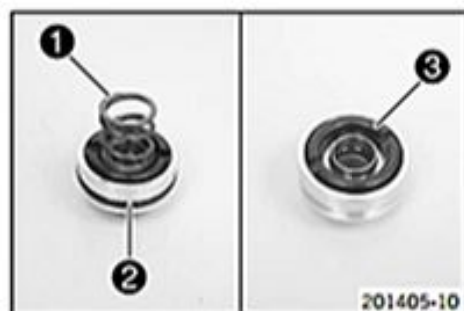

- Remove centering disk ④.
- Remove seal ring ⑤.

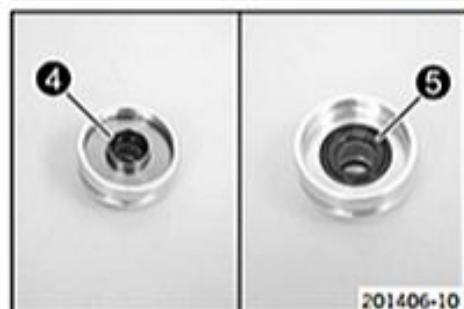

- Remove washer ⑥ for seal ring ⑤.
- Remove washer ⑦.
- Remove dust boot.

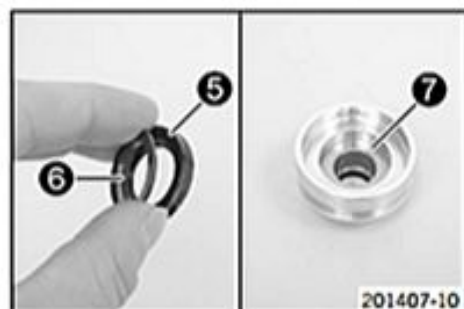

8.17 Changing the pilot bushing

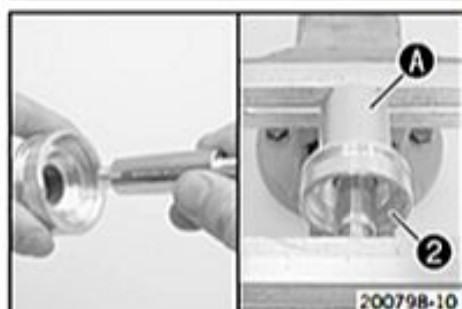
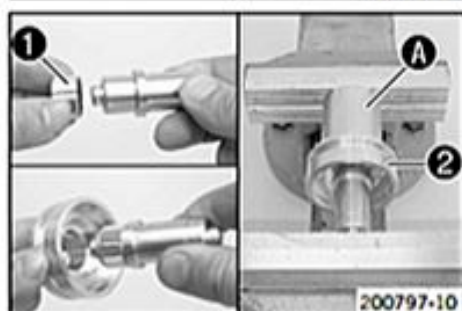
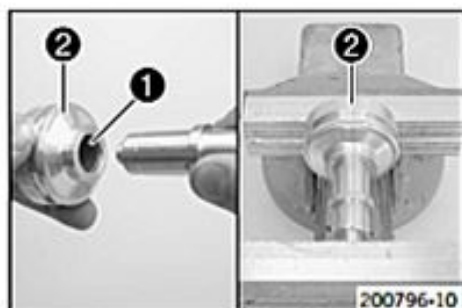
**Preparatory work**

- Remove the spring. (☛ p. 84)
- Disassemble the damper. (☛ p. 85)
- Disassemble the piston rod. (☛ p. 86)
- Disassemble the seal ring retainer. (☛ p. 87)

Main work

- Press pilot bushing 1 out of seal ring retainer 2 with the special tool.

Press drift (T1504) (☛ p. 276)

- Slide the new pilot bushing 1 onto the special tool.

Press drift (T1504) (☛ p. 276)

- Position the pilot bushing in the seal ring retainer using the special tool.

Press drift (T1504) (☛ p. 276)

- Support seal ring retainer 2 with sleeve A of the special tool. Press the pilot bushing all the way in.

Assembly tool (T150S) (☛ p. 276)

- Lubricate the special tool.

Shock absorber fluid (SAE 2.5) (50180751S1) (☛ p. 258)
--

Calibration pin (T1205) (☛ p. 271)

- Support seal ring retainer 2 with sleeve A of the special tool.

Assembly tool (T150S) (☛ p. 276)

- Press the special tool through the new pilot bushing.

Calibration pin (T1205) (☛ p. 271)

✓ The pilot bushing is calibrated.

Finishing work

- Assemble the seal ring retainer. (☛ p. 91)

8.18 Checking the damper

**Condition**

The damper has been disassembled.

- Measure the inside diameter on both ends and in the middle of the damper cartridge.

Damper cartridge	
Diameter	≤ 50.08 mm (≤ 1.9716 in)

- If the measured value is greater than the specified value:
 - Change the damper cartridge.
- Check the damper cartridge for damage and wear.
 - If there is damage or wear:
 - Change the damper cartridge.
- Check the heim joint for damage and wear.
 - If there is damage or wear:
 - Change the heim joint.



- Measure the diameter of the piston rod.

Piston rod	
Diameter	≥ 17.95 mm (≥ 0.7067 in)

- If the measured value is less than the specified value:
 - Change the piston rod.

- Measure the run-out of the piston rod.

Piston rod	
Run-out	≤ 0.02 mm (≤ 0.0008 in)

- If the measured value is greater than the specified value:
 - Change the piston rod.

- Check the piston rod for damage and wear.

- If there is damage or wear:
 - Change the piston rod.

- Check the piston rings for damage and wear.

- If damage or a bronze-colored surface is visible:
 - Change the piston.



8.19 Removing the heim joint

Condition

The shock absorber has been removed.

- Clamp the shock absorber in the vise using soft jaws for protection.
- Remove the collar bushing of the heim joint.

Pin (T120) (☛ p. 271)

- Turn the shock absorber and remove the second collar bushing of the heim joint.

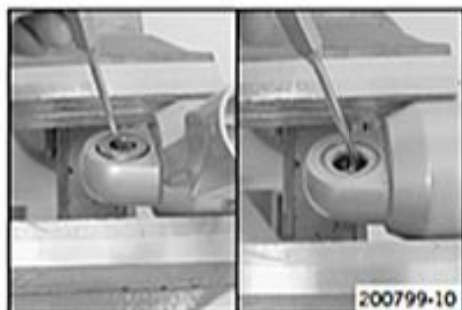

- Remove seal rings ① on both sides.

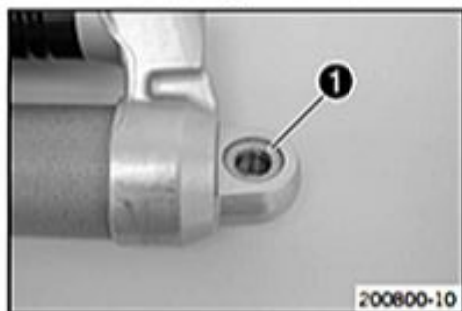

- Press the heim joint against a lock ring using the special tool.

Pressing tool (T1207S) (☛ p. 272)

- Remove the second lock ring ②.

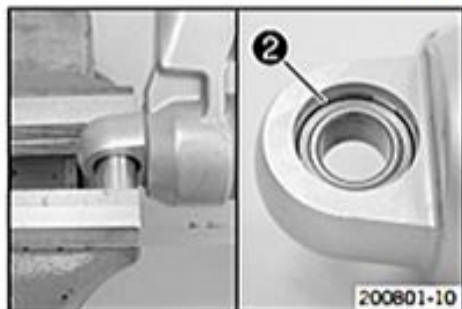

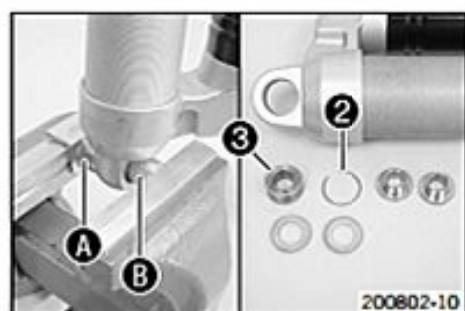

- Place special tool **A** underneath and press out heim joint **3** with special tool **B**.

Pressing tool (T1207S) (☛ p. 272)

8.20 Installing the heim joint



- Position the new heim joint **1** and the special tool into a vise as shown.

Guideline

Use soft jaws.

Pressing tool (T1206) (☛ p. 271)

- Press the heim joint all the way in.

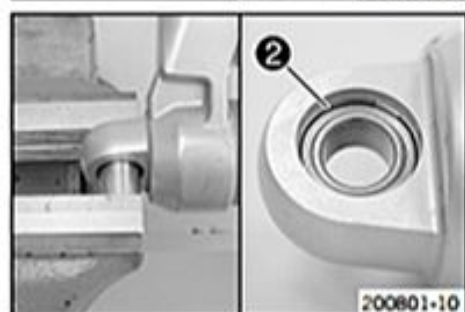

- Press the heim joint against the lock ring using the special tool.

Pressing tool (T1207S) (☛ p. 272)

- Mount the second lock ring **2**.

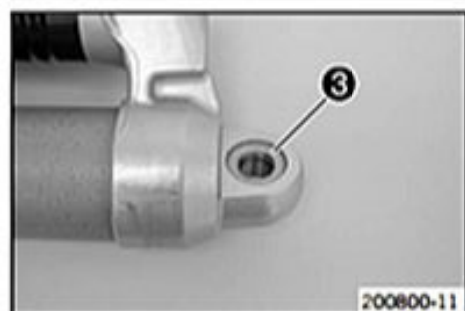

- Mount seal rings **3** on both sides.

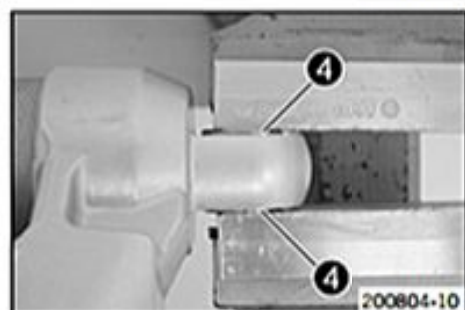

- Position both collar bushings **4** and press them in.

8.21 Assembling the seal ring retainer

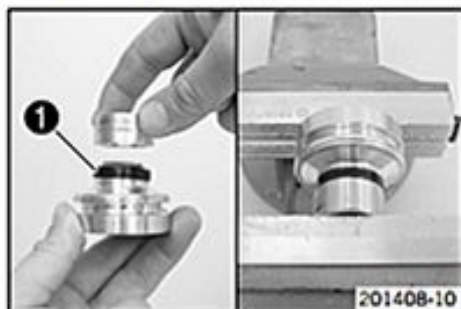

- Mount dust boot **1** using the special tool.

Mounting sleeve (T1204) (☞ p. 271)

- Lubricate the sealing lip of the dust boot.

Lubricant (T625) (☞ p. 260)



- Mount washer **2**.
- Position washer **3** on seal ring **4**.



- Grease seal ring **4** and mount with the washer facing downward.

Lubricant (T511) (☞ p. 260)

- Mount centering disk **5**.

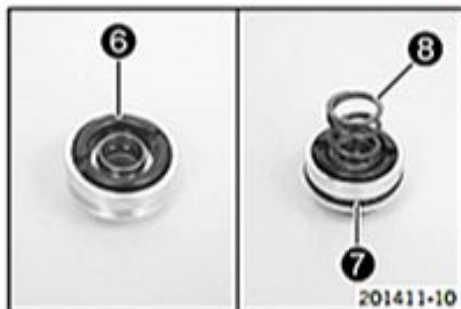

- Mount rebound rubber **6**.
- Lubricate the groove of the O-ring.

Lubricant (T158) (☞ p. 260)

- Mount O-ring **7**.
- Mount spring **8**.

8.22 Assembling the piston rod



Preparatory work

- Assemble the seal ring retainer. (☞ p. 91)

Main work

- Clamp the piston rod with the fork in a vise.

Guideline

Use soft jaws.

- Mount rubber buffer **1** and locking cap **2**.
- Position special tool on the piston rod.

Mounting sleeve (T1215) (☞ p. 272)

- Grease the dust boot and push seal ring retainer **3** onto the piston rod.

Lubricant (T625) (☞ p. 260)

- Remove the special tool.

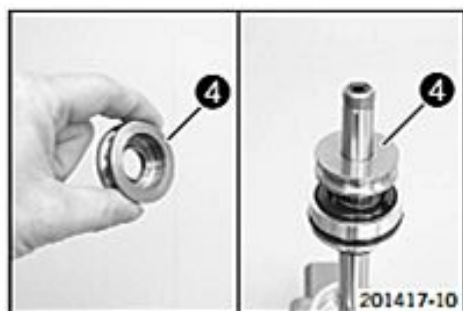

- Mount rebound washer 4 with the cut-out facing downward.



- Mount the compression shim stack 5 with the smaller shims facing downward.



- Sand both sides of piston 6 on a surface plate using 1200-grit sandpaper.
- Clean the piston.
- Assemble the piston.

Guideline

View A	Piston from above
View B	Piston from below



- Mount the rebound shim stack 7 with the smaller shims facing upward.

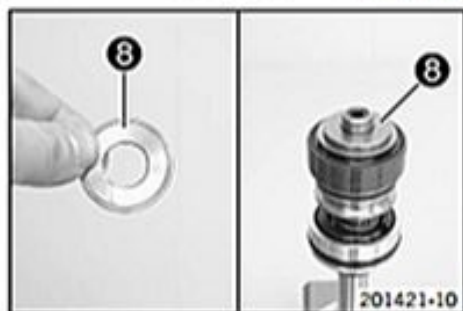

- Mount washer 8 with the collar facing downward.



- Grease the thread of the piston rod.

Lubricant (T152) (☛ p. 260)

- Mount and tighten nut 9.

Guideline

Nut, piston rod	M16x1	45 Nm (33.2 lbf ft)
-----------------	-------	------------------------

8.23 Assembling the damper



Preparatory work

- Assemble the seal ring retainer. (☞ p. 91)
- Assemble the piston rod. (☞ p. 91)

Main work

- Lubricate the O-rings of the compression adjuster.

Lubricant (T158) (☞ p. 260)

- Lubricate the threads.

Lubricant (T159) (☞ p. 260)

- Mount the piston with the spring.
- Mount and tighten the compression adjuster ①.

Guideline

Compression adjuster	M31x1	45 Nm (33.2 lbf ft)
----------------------	-------	------------------------

- Clamp the damper in a bench vise.

Guideline

Use soft jaws.

- Mount adjusting ring ② with the intermediate washer.



Info

The adjusting ring cannot be mounted after the piston rod is mounted.



- Fill the damper cartridge about half full.

Shock absorber fluid (SAE 2.5) (50180751S1) (☞ p. 258)

- Lubricate O-ring ③ of the seal ring retainer.

Lubricant (T158) (☞ p. 260)

- Mount the piston rod carefully.



- Install the seal ring bearer ④ and push it under the ring groove.

- Mount lock ring ⑤.



Info

Do not scratch the inner surface.

- Pull out the piston rod so that the seal ring retainer rests against the lock ring.



- Mount locking cap ⑥ of the damper cartridge.

- Bleed and fill the damper. (☞ p. 95)

- Fill the damper with nitrogen. (☞ p. 97)



- Mount rubber cap 7 of the reservoir.



Alternative 1

- Turn adjusting screw 8 clockwise with a screwdriver up to the last perceptible click.
- Turn counterclockwise by the number of clicks corresponding to the shock absorber type.

Guideline

Compression damping, low-speed	
Comfort	17 clicks
Standard	15 clicks
Sport	13 clicks

- Turn adjusting screw 9 all the way clockwise with a socket wrench.
- Turn counterclockwise by the number of turns corresponding to the shock absorber type.

Guideline

Compression damping, high-speed	
Comfort	2.5 turns
Standard	2 turns
Sport	1.5 turns

- Turn adjusting screw 10 clockwise up to the last perceptible click.
- Turn counterclockwise by the number of clicks corresponding to the shock absorber type.

Guideline

Rebound damping	
Comfort	17 clicks
Standard	15 clicks
Sport	13 clicks

Alternative 2



Warning

Danger of accidents Modifications to the suspension settings can seriously alter the vehicle's ride behavior.

- Extreme modifications to the adjustment of the suspension components can cause a serious deterioration in the handling characteristics and overload some components.
- Only make adjustments within the recommended range.
- After making adjustments, ride slowly at first to get the feel of the new ride behavior.

- Turn adjusting screws 8, 9 and 10 to the position determined during disassembly.

8.24 Bleeding and filling the damper



Info

Before working with the vacuum pump, be sure to read the operating instructions carefully. Completely open the adjusters of the rebound and compression damping.



- Remove the screw of the filling port.
- Install adapter ① on the damper.



Info

Tighten only hand-tight, without the use of tools.

- Connect the adapter ① to connector ② of the vacuum pump.

Vacuum pump (T1240S) (☞ p. 272)

- Clamp the damper with soft jaws or hold it as shown in the figure.



Info

Clamp the damper only lightly.
The filling port must be at the highest point.
The piston rod slides in and out during filling - do not hold it tight with your hand!



- Clamp the control lever as shown in the figure.
 - ✓ The External tank ③ control lever is on Closed, Damper ④ on Vacuum, and Oil reservoir ⑤ on Vacuum.

- Operate the On/Off switch ⑥.

- ✓ The vacuum pump process starts.
- ✓ Pressure gauge ⑦ drops to the specified value.

< 0 bar

- ✓ The vacuum gauge ⑧ falls to the specified value.

4 mbar

- Measure distance A between the floating piston and reservoir hole with the special tool.

Depth micrometer (T107S) (☞ p. 271)

- ✓ The floating piston is positioned all the way at the bottom.



- When the vacuum pressure gauge reaches the specified value, turn the Oil reservoir control lever ⑤ to Equalize pressure.

Guideline

4 mbar

- ✓ The pressure gauge increases to the specified value.

0 bar

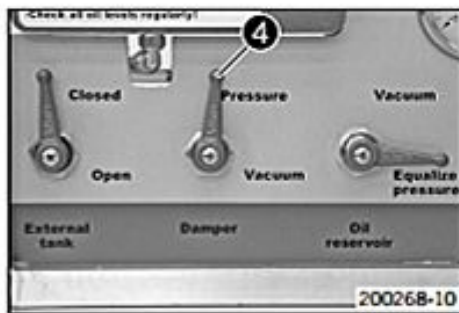

- When the pressure gauge reaches the specified value, turn the **Damper control lever 4** to **Pressure**.

Guideline

- ✓ Oil is pumped into the damper.
- ✓ The pressure gauge increases to the specified value.

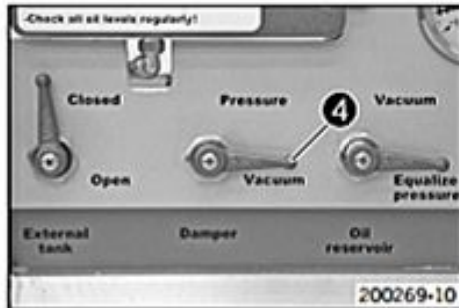

- When the pressure gauge reaches the specified value, turn the **Damper 4** control lever to **Vacuum**.

Guideline

- ✓ The pressure gauge drops to the specified value.

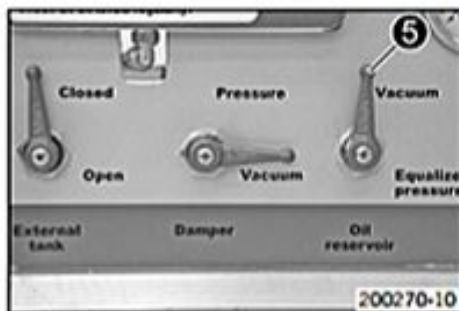

- When the pressure gauge reaches the specified value, turn the **Oil reservoir 5** control lever to **Vacuum**.

Guideline

- ✓ The vacuum gauge falls to the specified value.

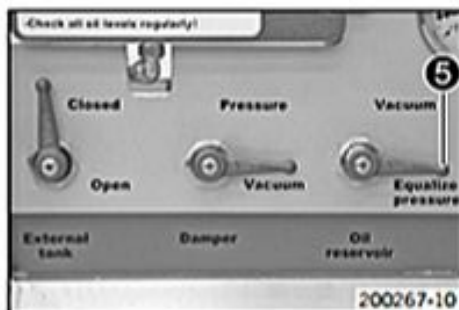

- When the vacuum pressure gauge reaches the specified value, turn the **Oil reservoir control lever 5** to **Equalize Pressure**.

Guideline

- ✓ The pressure gauge drops to the specified value.

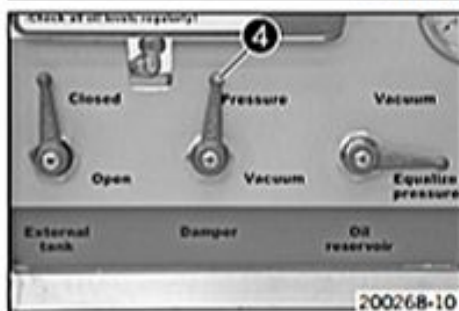

- When the pressure gauge reaches the specified value, turn the **Damper control lever 4** to **Pressure**.

Guideline

- ✓ Oil is pumped into the damper.
- ✓ The pressure gauge increases to the specified value.

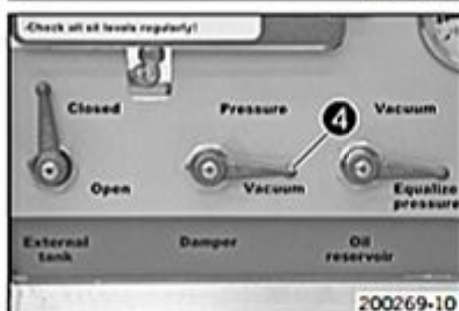

- When the pressure gauge reaches the specified value, turn the **Damper 4** control lever to **Vacuum**.

Guideline

- ✓ The pressure gauge drops to the specified value.

- When the pressure gauge reaches the specified value, operate the **On/Off** switch.

Guideline

- ✓ The vacuum pump is switched off.

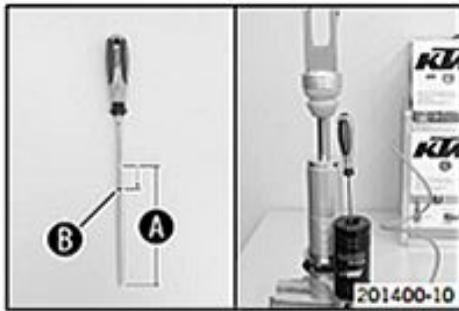

- Slide O-ring **B** to the end of the special tool by the specified value (distance **A** minus specified value).

Guideline

10 mm

Depth micrometer (T107S) (☛ p. 271)

- Slide the floating piston into the reservoir to the shortened position using the special tool.

i Info

The floating piston must be positioned at exactly this point when the rod is fully extended; otherwise, damage will occur during compression of the shock absorber.

- Remove the special tool.
- Remove adapter **1** from connection **2** of the vacuum pump.

i Info

Hold the damper so that the filling port is at the highest point.

- Remove the adapter.
- Mount and tighten screw **9**.

Guideline

Screw, filling port	M10x1	14 Nm (10.3 lbf ft)
---------------------	-------	------------------------

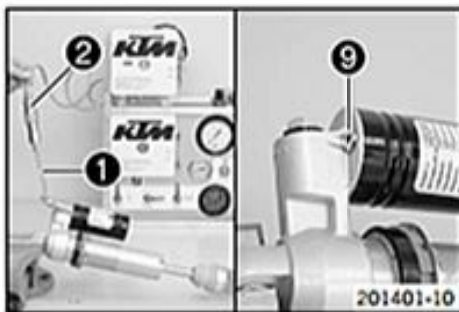

8.25 Filling the damper with nitrogen

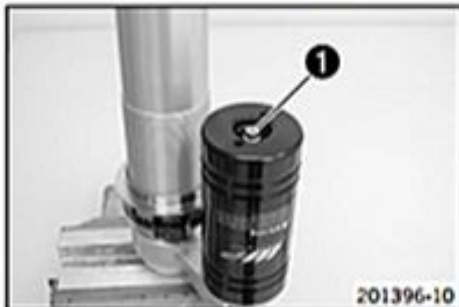

- Screw in screw **1** by approx. 2 rotations but do not tighten.

i Info

The piston rod is fully extended.



- Clamp the special tool in the vise.

Nitrogen filling tool (T170S1) (☛ p. 276)

- Connect the special tool to the pressure regulator of the filling cylinder.

Filling gas - nitrogen

- Adjust the pressure regulator.

Guideline

Gas pressure	10 bar (145 psi)
--------------	------------------

- Position the damper in the special tool.

✓ The hexagonal part of the tap handle **A** engages in the hexagon socket of the filling port screw.

- Open filler tap **B**.
- Fill the damper for at least 15 seconds.

Guideline

Gas pressure	10 bar (145 psi)
--------------	------------------

i Info

Watch the pressure regulator dial. Make sure that the damper is filled to the specified pressure.

- Close the filling port screw using tap handle **A**.
- Close spigot **B** and take the damper out of the special tool.
- Tighten the filling port screw.

Guideline

Screw, reservoir filling port	M5	3 Nm (2.2 lbf ft)
-------------------------------	----	-------------------

8.26 Installing the spring



201372-10

- Ensure that adjusting ring **1** is screwed on with the intermediate washer.

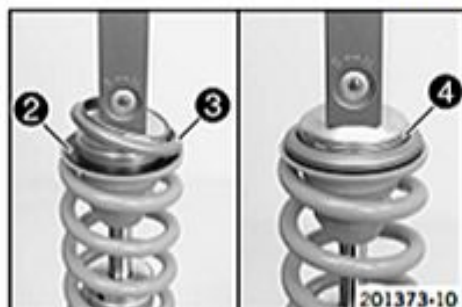

201373-10

- Measure the overall spring length while the spring is not under tension.
- Position spring.

Guideline

Spring rate	
Weight of rider: 65... 75 kg (143... 165 lb.)	54 N/mm (308 lb/in)
Weight of rider: 75... 85 kg (165... 187 lb.)	57 N/mm (325 lb/in)
Weight of rider: 85... 95 kg (187... 209 lb.)	60 N/mm (343 lb/in)

- Mount intermediate washer **2** and spring retainer **3**.
- Mount ring **4**.

Alternative 1

- Tension the spring to the prescribed amount by turning the adjusting ring.

Guideline

Spring preload	8 mm (0.31 in)
----------------	----------------

Hook wrench (T106S) (☛ p. 270)

Alternative 2



Warning

Danger of accidents Modifications to the suspension settings can seriously alter the vehicle's ride behavior.

- Extreme modifications to the adjustment of the suspension components can cause a serious deterioration in the handling characteristics and overload some components.
 - Only make adjustments within the recommended range.
 - After making adjustments, ride slowly at first to get the feel of the new ride behavior.
- Tension the spring to the amount measured during dismantling by turning the adjusting ring.

Hook wrench (T106S) (☛ p. 270)

8 SHOCK ABSORBER, SWINGARM



- Tighten screw ⑤.

Guideline

Screw, shock absorber adjusting ring	M5	5 Nm (3.7 lbf ft)
--------------------------------------	----	-------------------

9.1 Removing the manifold

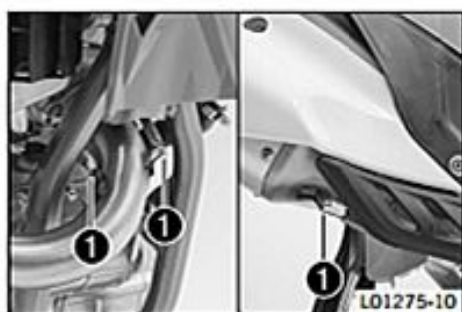

- Detach springs ①.

Spring hooks (50305017000) (☛ p. 263)



- Remove screw ②.
- Take off manifold.

9.2 Installing the manifold



- Feed in and position the manifold.
- Mount screw ① but do not tighten yet.

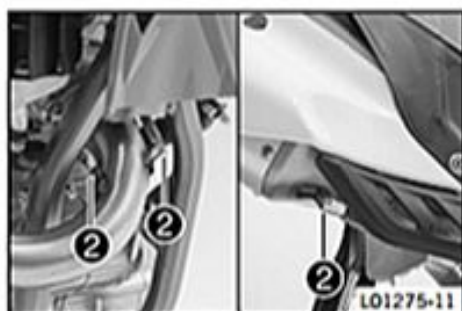

- Attach springs ②.

Spring hooks (50305017000) (☛ p. 263)

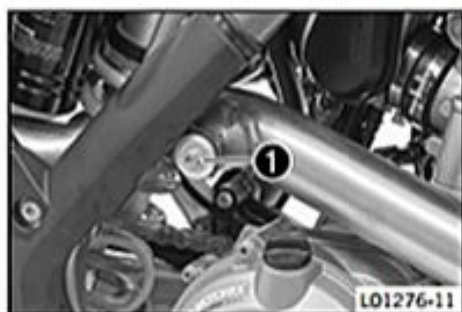

- Tighten screw ①.

Guideline

Remaining screws, chassis	M8	25 Nm (18.4 lbf ft)
---------------------------	----	------------------------

9.3 Removing the main silencer

**Warning****Danger of burns** The exhaust system gets very hot when the vehicle is driven.

- Allow the exhaust system to cool down. Do not touch hot components.

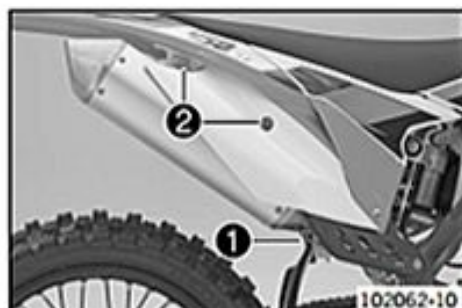

- Disconnect spring ①.

Spring hooks (50305017000) (☛ p. 263)

- Remove screws ② and take off the main silencer.

9.4 Installing the main silencer



- Position the main silencer.
- Mount screws ① but do not tighten yet.
- Reconnect spring ②.

Spring hooks (50305017000) (☛ p. 263)

- Tighten screws ①.

Guideline

Remaining screws, chassis	M6	10 Nm (7.4 lbf ft)
---------------------------	----	--------------------

9.5 Changing the glass fiber yarn filling of the main silencer

**Warning****Danger of burns** The exhaust system gets very hot when the vehicle is driven.

- Allow the exhaust system to cool down. Do not touch hot components.

**Info**

Over time, the fibers of the glass fiber yarn escape and the damper "burns" out. Not only is the noise level higher, the performance characteristic changes.

Preparatory work

- Remove the main silencer. (☛ p. 101)

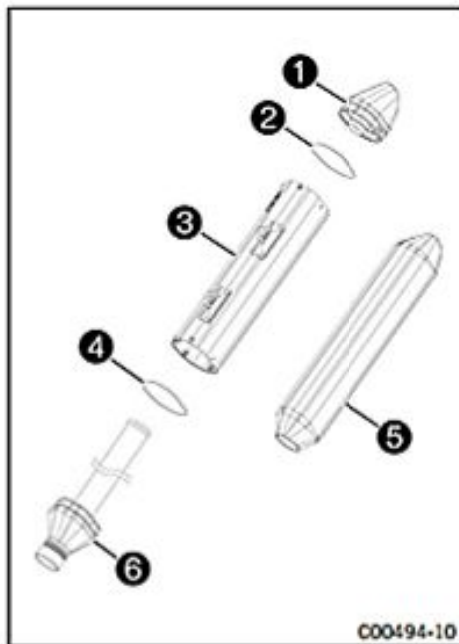

Main work

- Remove all screws from the main silencer.
- Remove silencer cap ① and O-ring ②.
- Remove outer tube ③ and O-ring ④.
- Pull the glass fiber yarn filling ⑤ from the inner tube ⑥.
- Clean the parts that are to be reinstalled.
- Mount the new glass fiber yarn filling ⑤ on inner tube ⑥.
- Slide O-ring ④ and outer tube ③ over the glass fiber yarn filling ⑤.
- Insert O-ring ② and silencer cap ① into outer tube ③.
- Mount and tighten all screws.

Finishing work

- Install the main silencer. (☛ p. 101)

10.1 Removing the air filter box lid



Condition

The air filter box lid is secured.

- Remove screws 1.



- Pull off the air filter box lid in area A sideways and remove it toward the front.

10.2 Installing the air filter box lid

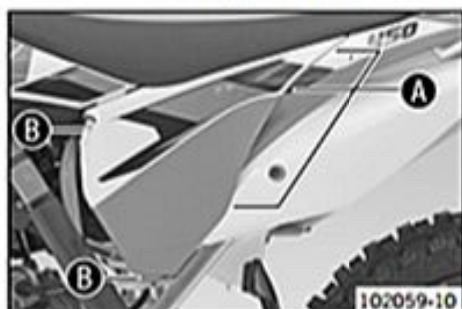

- Insert the air filter box lid into rear area A and clip it into front area B.

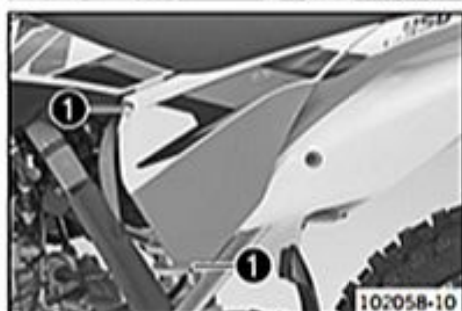

Condition

The air filter box lid is secured.

- Mount and tighten screws 1.

Guideline

Screw, air filter box lid	EJOT PT® K60x20-Z	3 Nm (2.2 lbf ft)
EJOT PT screw (0017060204)		

10.3 Removing the air filter

Note

Engine failure Unfiltered intake air has a negative effect on the service life of the engine.

- Never operate the vehicle without an air filter as dust and dirt will enter the engine and lead to increased wear.

Warning

Environmental hazard Hazardous substances cause environmental damage.

- Oil, grease, filters, fuel, cleaners, brake fluid, etc., should be disposed of as stipulated in applicable regulations.

Preparatory work

- Remove the air filter box lid. (☛ p. 103)



Main work

- Detach air filter holder ① at the bottom and swing it to one side. Remove the air filter with the air filter support.
- Remove the air filter from the air filter support.

10.4 Installing the air filter

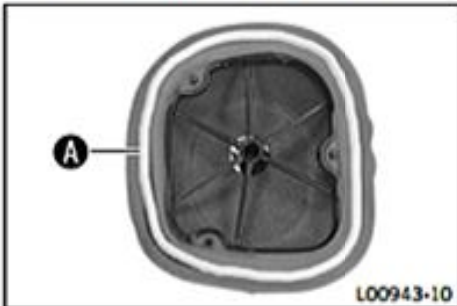

Main work

- Mount the clean air filter on the air filter support.
- Grease the air filter in area ①.

Long-life grease (☞ p. 260)



- Insert both parts together, position them, and fasten them using air filter holder ①.

✓ The arrow of marking UP faces upward.

i Info

If the air filter is not mounted correctly, dust and dirt may enter the engine and cause damage.

Finishing work

- Install the air filter box lid. (☞ p. 103)

10.5 Cleaning the air filter and air filter box

Warning

Environmental hazard Hazardous substances cause environmental damage.

- Oil, grease, filters, fuel, cleaners, brake fluid, etc., should be disposed of as stipulated in applicable regulations.

i Info

Do not clean the air filter with fuel or petroleum since these substances attack the foam.

Preparatory work

- Remove the air filter box lid. (☞ p. 103)
- Remove the air filter. (☞ p. 103)

Main work

- Wash the air filter thoroughly in special cleaning liquid and allow it to dry properly.

Air filter cleaner (☞ p. 260)

i Info

Only press the air filter to dry it, never wring it out.

- Oil the dry air filter with a high quality filter oil.

Oil for foam air filter (☞ p. 261)

- Clean the air filter box.



- Clean the intake flange and check it for damage and tightness.

Finishing work

- Install the air filter. (☞ p. 104)
- Install the air filter box lid. (☞ p. 103)

10.6 Sealing the air filter box

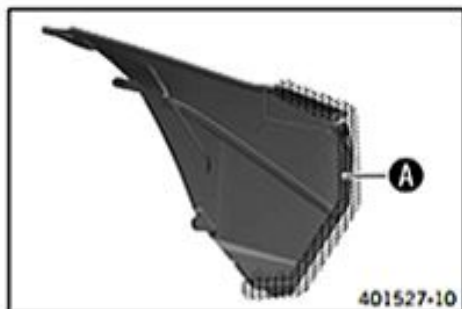

Preparatory work

- Remove the air filter box lid. (☞ p. 103)

Main work

- Seal the air filter box in marked area **A**.

Finishing work

- Install the air filter box lid. (☞ p. 103)

10.7 Securing the air filter box lid

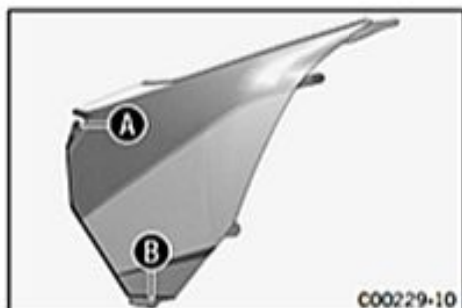

Preparatory work

- Remove the air filter box lid. (☞ p. 103)

Main work

- Drill a hole at markings **A** and **B**.

Guideline

Diameter	6 mm (0.24 in)
----------	----------------

Finishing work

- Install the air filter box lid. (☞ p. 103)

11.1 Opening the filler cap

Danger

Fire hazard Fuel is highly flammable.

- Never refuel the vehicle near open flames or burning cigarettes, and always switch off the engine first. Be careful that no fuel is spilt, especially on hot vehicle components. Clean up spilt fuel immediately.
- The fuel in the fuel tank expands when warm and may emerge if overfilled. Follow the instructions on refueling.

Warning

Danger of poisoning Fuel is poisonous and a health hazard.

- Fuel must not come into contact with the skin, eyes, or clothing. Do not breathe in the fuel vapors. If contact occurs with the eyes, rinse with water immediately and contact a physician. Immediately clean contaminated areas on the skin with soap and water. If fuel is swallowed, contact a physician immediately. Change clothing that is contaminated with fuel. Store fuel properly in a suitable canister and keep away from children.

Warning

Environmental hazard Improper handling of fuel is a danger to the environment.

- Do not allow fuel to get into the ground water, the ground, or the sewage system.



(SX-F EU, SX-F USA)

- Turn filler cap **1** counterclockwise and lift it off.



(XC-F)

- Press release button **1**, turn the filler cap counterclockwise, and lift it free.

11.2 Closing the filler cap

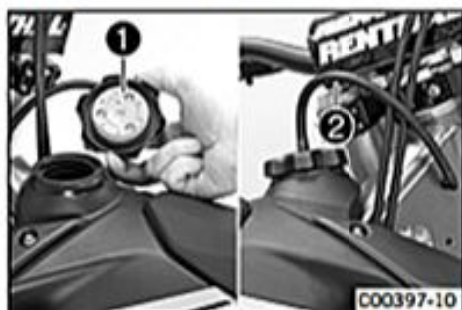

(SX-F EU, SX-F USA)

- Mount filler cap **1** and turn it clockwise until the fuel tank is tightly closed.



Info

Run the fuel tank breather hose **2** without kinks.

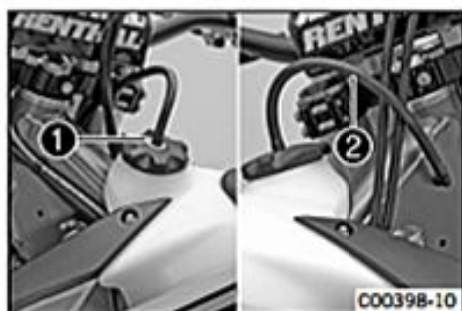

(XC-F)

- Replace the filler cap and turn clockwise until the release button **1** locks in place.



Info

Run the fuel tank breather hose **2** without kinks.

11.3 Removing the seat



- Remove screw ❶.
- Lift up the seat at the rear, pull it back and then remove it from above.

11.4 Mounting the seat



- Hook in the front of the seat at the collar bushing of the fuel tank, lower it at the rear and simultaneously it push forward.
- Make sure that the seat is correctly locked in.
- Mount and tighten the screw of the seat fixing.

Guideline

Remaining screws, chassis	M6	10 Nm (7.4 lbf ft)
---------------------------	----	--------------------

11.5 Removing the fuel tank



Danger

Fire hazard Fuel is highly flammable.

- Never refuel the vehicle near open flames or burning cigarettes, and always switch off the engine first. Be careful that no fuel is spilt, especially on hot vehicle components. Clean up spilt fuel immediately.
- The fuel in the fuel tank expands when warm and may emerge if overfilled. Follow the instructions on refueling.



Warning

Danger of poisoning Fuel is poisonous and a health hazard.

- Fuel must not come into contact with the skin, eyes, or clothing. Do not breathe in the fuel vapors. If contact occurs with the eyes, rinse with water immediately and contact a physician. Immediately clean contaminated areas on the skin with soap and water. If fuel is swallowed, contact a physician immediately. Change clothing that is contaminated with fuel. Store fuel properly in a suitable canister and keep away from children.

Preparatory work

- Remove the seat. (☛ p. 107)

Main work

- Unplug connector ❶ of the fuel pump.

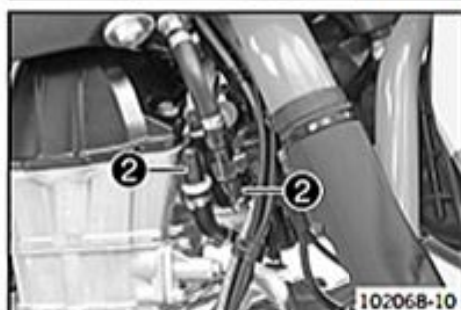

- Thoroughly clean the plug-in connection of the fuel line using compressed air.



Info

Under no circumstances should dirt enter into the fuel line. Dirt in the fuel line clogs the injection valve.

- Disconnect the plug-in connection of the fuel line.
- Mount wash cap set ❷.

Wash cap set (81212016100)



- Remove the tube from the fuel tank breather.
- Remove screws 3 with the collar bushing.



- Remove screw 4 with the rubber bushing.



- Pull both spoilers off of the sides of the radiator bracket and lift off the fuel tank.

11.6 Installing the fuel tank



Danger

Fire hazard Fuel is highly flammable.

- Never refuel the vehicle near open flames or burning cigarettes, and always switch off the engine first. Be careful that no fuel is spilt, especially on hot vehicle components. Clean up spilt fuel immediately.
- The fuel in the fuel tank expands when warm and may emerge if overfilled. Follow the instructions on refueling.



Warning

Danger of poisoning Fuel is poisonous and a health hazard.

- Fuel must not come into contact with the skin, eyes, or clothing. Do not breathe in the fuel vapors. If contact occurs with the eyes, rinse with water immediately and contact a physician. Immediately clean contaminated areas on the skin with soap and water. If fuel is swallowed, contact a physician immediately. Change clothing that is contaminated with fuel.

Main work

- Check the throttle cable routing. (☛ p. 74)
- Position the fuel tank and fit the two spoilers to the sides of the radiator bracket.
- Make sure that no cables are trapped or damaged.
- Mount the fuel tank breather.
- Mount and tighten screw 1 with the rubber bushing.

Guideline

Remaining screws, chassis	M6	10 Nm (7.4 lbf ft)
---------------------------	----	--------------------





- Mount and tighten screws ② with the collar bushing.

Guideline

Remaining screws, chassis	M6	10 Nm (7.4 lbf ft)
---------------------------	----	--------------------



- Plug in connector ③ of the fuel pump.
- Remove the wash cap set. Thoroughly clean the plug-in connection of the fuel line using compressed air.

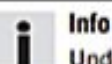

Info

Under no circumstances should dirt enter into the fuel line. Dirt in the fuel line clogs the injection valve.

- Lubricate the O-ring and connect plug-in connection ④ of the fuel line.

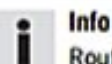

Info

Route the cable and fuel line at a safe distance from the exhaust system.

Finishing work

- Mount the seat. (☛ p. 107)

11.7 Checking the fuel pressure



Danger

Fire hazard Fuel is highly flammable.

- Never refuel the vehicle near open flames or burning cigarettes, and always switch off the engine first. Be careful that no fuel is spilt, especially on hot vehicle components. Clean up spilt fuel immediately.
- The fuel in the fuel tank expands when warm and may emerge if overfilled. Follow the instructions on refueling.



Warning

Danger of poisoning Fuel is poisonous and a health hazard.

- Fuel must not come into contact with the skin, eyes, or clothing. Do not breathe in the fuel vapors. If contact occurs with the eyes, rinse with water immediately and contact a physician. Immediately clean contaminated areas on the skin with soap and water. If fuel is swallowed, contact a physician immediately. Change clothing that is contaminated with fuel. Store fuel properly in a suitable canister and keep away from children.

Condition

The fuel tank is full.

Ensure that the battery voltage does not drop below 12.5 V.

The diagnostic tool is disconnected.

- Press on the small metal plate and disconnect fuel hose connection ①.



Info

Remaining fuel may flow out of the fuel hose.



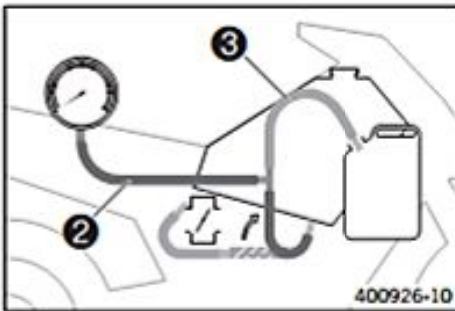

- Mount special tool ②.

Pressure testing tool (61029094000) (☞ p. 266)
--

- Mount special tool ③ with nozzle label 0,60.

Testing hose (61029093000) (☞ p. 266)

- Position the hose end in a fuel canister.

Guideline

Minimum size of fuel canister	10 l (2.6 US gal)
-------------------------------	-------------------

- Connect the diagnostic tool and start it.

- Select the "Function test of fuel pump control" actuator test.

Guideline

Maximum duration of the actuator test	3 min
---------------------------------------	-------

- Check the fuel pressure with the filler cap closed.

Fuel pressure

When the fuel pump is active	3.3... 3.7 bar (48... 54 psi)
------------------------------	-------------------------------

- If the specification is not reached:

- Open the filler cap. (☞ p. 106)
- Check the tank air vent system.

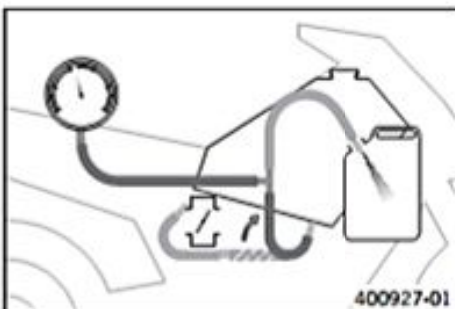

- Check the fuel pressure with the filler cap open.

Fuel pressure

When the fuel pump is active	3.3... 3.7 bar (48... 54 psi)
------------------------------	-------------------------------

- If the specification is not reached:

- Check that the fuel line is clear.
- Change the fuel filter. (☞ p. 112)
- Change the fuel pump. (☞ p. 110)

- Stop the "Function test of fuel pump control" actuator test by pressing the "Quit" button.

- Remove the special tools.

- Join the fuel hose connection.

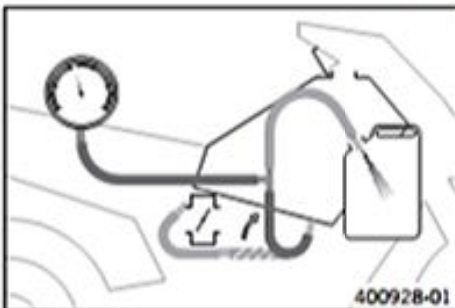

11.8 Changing the fuel pump



Danger

Fire hazard Fuel is highly flammable.

- Never refuel the vehicle near open flames or burning cigarettes, and always switch off the engine first. Be careful that no fuel is spilled, especially on hot vehicle components. Clean up spilled fuel immediately.
- The fuel in the fuel tank expands when warm and may emerge if overfilled. Follow the instructions on refueling.



Warning

Danger of poisoning Fuel is poisonous and a health hazard.

- Fuel must not come into contact with the skin, eyes, or clothing. Do not breathe in the fuel vapors. If contact occurs with the eyes, rinse with water immediately and contact a physician. Immediately clean contaminated areas on the skin with soap and water. If fuel is swallowed, contact a physician immediately. Change clothing that is contaminated with fuel. Store fuel properly in a suitable canister and keep away from children.



Warning

Environmental hazard Improper handling of fuel is a danger to the environment.

- Do not allow fuel to get into the ground water, the ground, or the sewage system.

Preparatory work

- Drain the fuel from the fuel tank into a suitable container.
- Remove the seat. (☞ p. 107)
- Remove the fuel tank. (☞ p. 107)

Main work

- Remove nut ① with the gasket.
- Remove fuel connection ② with the gasket.



- Remove screws ③.

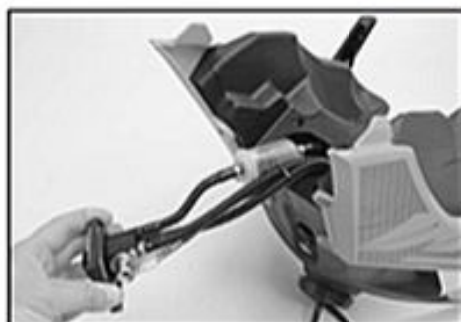

- Pull out the fuel pump.

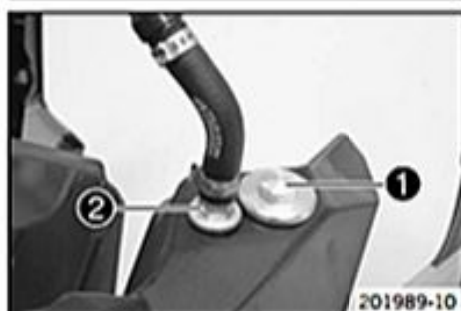

- Position the fuel pump.
- Mount fuel connection ② with the gasket but do not tighten yet.
- Mount and tighten nut ① with the gasket.

Guideline

Nut, fuel pump fixation	M12x1.75	15 Nm (11.1 lbf ft)
-------------------------	----------	------------------------

- Tighten fuel connection ②.

Guideline

Fuel connection on fuel tank	M8x1.25	10 Nm (7.4 lbf ft)
------------------------------	---------	--------------------

- Mount and tighten screws ③.

Guideline

Screw, fuel pump	EJOT	3 Nm (2.2 lbf ft)
------------------	------	-------------------



Finishing work

- Install the fuel tank. (☛ p. 108)
- Mount the seat. (☛ p. 107)

11.9 Changing the fuel filter



Danger

Fire hazard Fuel is highly flammable.

- Never refuel the vehicle near open flames or burning cigarettes, and always switch off the engine first. Be careful that no fuel is spilled, especially on hot vehicle components. Clean up spilled fuel immediately.
- The fuel in the fuel tank expands when warm and may emerge if overfilled. Follow the instructions on refueling.



Warning

Danger of poisoning Fuel is poisonous and a health hazard.

- Fuel must not come into contact with the skin, eyes, or clothing. Do not breathe in the fuel vapors. If contact occurs with the eyes, rinse with water immediately and contact a physician. Immediately clean contaminated areas on the skin with soap and water. If fuel is swallowed, contact a physician immediately. Change clothing that is contaminated with fuel. Store fuel properly in a suitable canister and keep away from children.



Warning

Environmental hazard Improper handling of fuel is a danger to the environment.

- Do not allow fuel to get into the ground water, the ground, or the sewage system.

Preparatory work

- Drain the fuel from the fuel tank into a suitable container.
- Remove the seat. (☛ p. 107)
- Remove the fuel tank. (☛ p. 107)

Main work

- Remove nut ① with the gasket.
- Remove fuel connection ② with the gasket.



- Remove screws ③.



- Pull out the fuel pump.
- Remove hose clamps ④.
- Remove fuel filter ⑤.

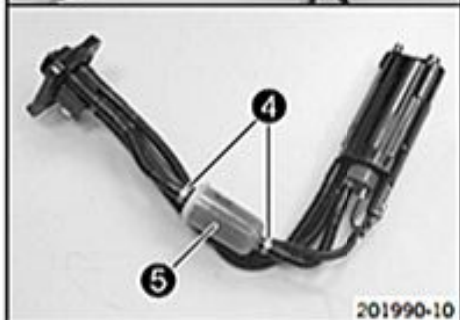

201990-10

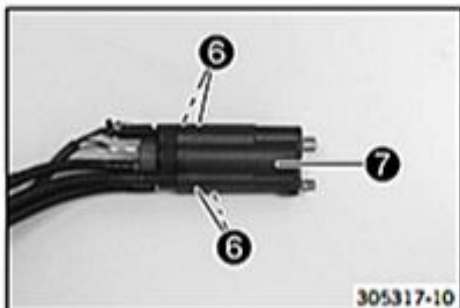

305317-10

- Press locking mechanism ⑥.
- Pull back fuel pump housing ⑦.



305318-10

- Change fuel screen ⑧.
- Mount the fuel pump housing.

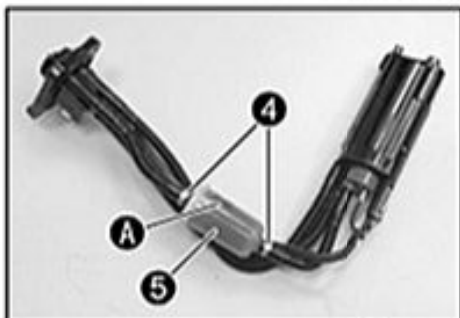

- Mount fuel filter ⑤.
- ✓ Arrow A points away from the fuel pump.
- Mount hose clamps ④.

Hose clamp pliers (60029057000) (☛ p. 265)



201990-11



- Position the fuel pump.
- Mount fuel connection ② with the gasket but do not tighten yet.
- Mount and tighten nut ① with the gasket.

Guideline

Nut, fuel pump fixation	M12x1.75	15 Nm (11.1 lbf ft)
-------------------------	----------	------------------------

- Tighten fuel connection ②.

Guideline

Fuel connection on fuel tank	M8x1.25	10 Nm (7.4 lbf ft)
------------------------------	---------	--------------------

- Mount and tighten screws ③.

Guideline

Screw, fuel pump	EJOT	3 Nm (2.2 lbf ft)
------------------	------	-------------------



Finishing work

- Install the fuel tank. (☛ p. 108)
- Mount the seat. (☛ p. 107)

11.10 Changing the fuel screen

**Danger**

Fire hazard Fuel is highly flammable.

- Never refuel the vehicle near open flames or burning cigarettes, and always switch off the engine first. Be careful that no fuel is spilt, especially on hot vehicle components. Clean up spilt fuel immediately.
- The fuel in the fuel tank expands when warm and may emerge if overfilled. Follow the instructions on refueling.

**Warning**

Danger of poisoning Fuel is poisonous and a health hazard.

- Fuel must not come into contact with the skin, eyes, or clothing. Do not breathe in the fuel vapors. If contact occurs with the eyes, rinse with water immediately and contact a physician. Immediately clean contaminated areas on the skin with soap and water. If fuel is swallowed, contact a physician immediately. Change clothing that is contaminated with fuel.

**Warning**

Environmental hazard Improper handling of fuel is a danger to the environment.

- Do not allow fuel to get into the ground water, the ground, or the sewage system.

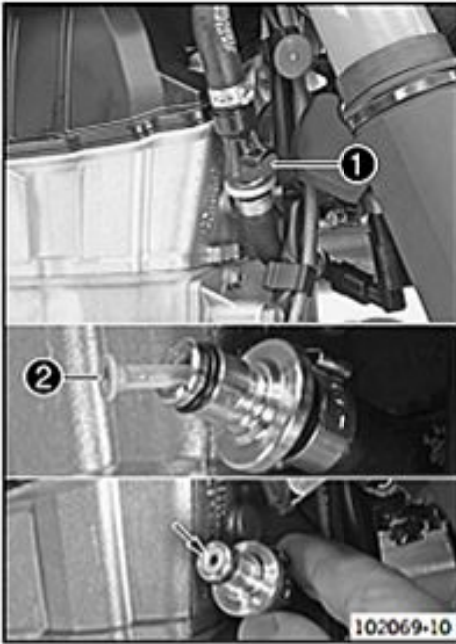

- Thoroughly clean plug-in connection ① of the fuel line using compressed air.

**Info**

Under no circumstances should dirt enter into the fuel line. Dirt in the fuel line clogs the injection valve.

- Disconnect the plug-in connection of the fuel line.
- Pull fuel screen ② out of the connecting piece.
- Push the new fuel screen all the way into the connecting piece.
- Lubricate the O-ring and connect plug-in connection of the fuel line.

**Danger**

Danger of poisoning Exhaust gases are toxic and inhaling them may result in unconsciousness and/or death.

- When running the engine, always make sure there is sufficient ventilation, and do not start or run the engine in an enclosed space without an effective exhaust extraction system.

- Start the engine and check the response.

12.1 Removing the front fender

Preparatory work

- Remove the start number plate. (☞ p. 116)

Main work

- Remove screws ① and ②. Remove the front fender.

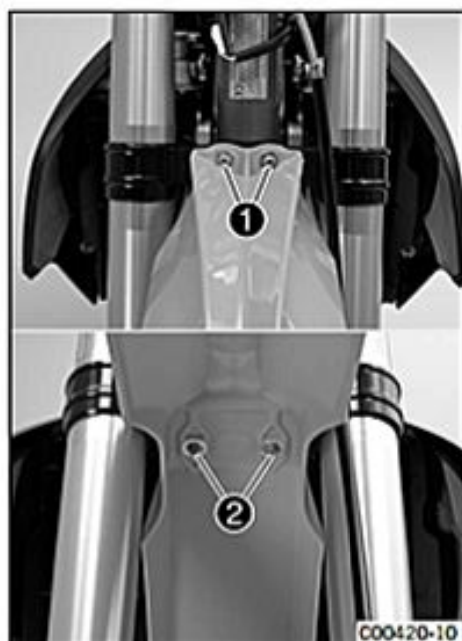

12.2 Installing the front fender

Main work

- Position the front fender. Mount and tighten screws ① and ②.

Guideline

Remaining screws, chassis	M6	10 Nm (7.4 lbf ft)
---------------------------	----	--------------------

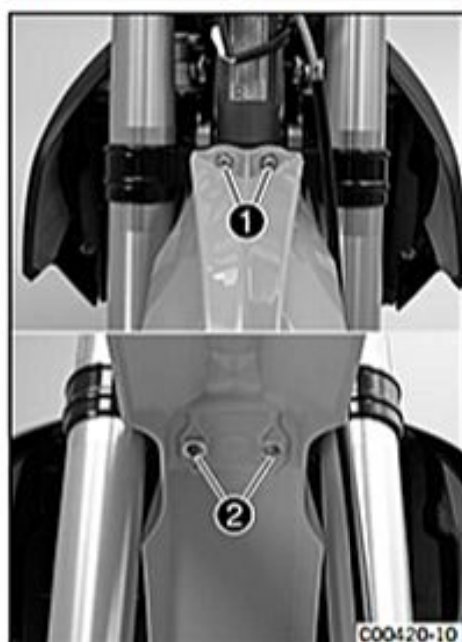

Finishing work

- Install the start number plate. (☞ p. 117)

12.3 Removing the start number plate



- Remove screw ① and take off the clamp.
- Remove screw ②. Take off the start number plate.

12.4 Installing the start number plate



- Position the start number plate. Mount and tighten screw ❶.

Guideline

Remaining screws, chassis	M6	10 Nm (7.4 lbf ft)
---------------------------	----	--------------------

- ✓ The holding lugs engage.

- Position the brake line and clamp. Mount and tighten screw ❷.

13.1 Checking the tire air pressure

i Info
 Low tire air pressure leads to abnormal wear and overheating of the tire.
 Correct tire air pressure ensures optimal riding comfort and maximum tire service life.

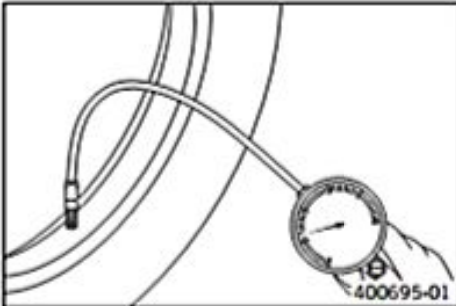

- Remove the protection cap.
- Check the tire air pressure when the tires are cold.

Tire air pressure off road	
Front	1.0 bar (15 psi)
Rear	1.0 bar (15 psi)

- If the tire pressure does not meet specifications:
 - Correct the tire pressure.
- Mount the protection cap.

13.2 Checking the tire condition

i Info
 Only mount tires approved and/or recommended by KTM.
 Other tires could have a negative effect on handling characteristics.
 The type, condition and air pressure of the tires all have an important impact on the handling characteristics of the motorcycle.
 The front and rear wheels must be mounted with tires with similar profiles.
 Worn tires have a negative effect on handling characteristics, especially on wet surfaces.

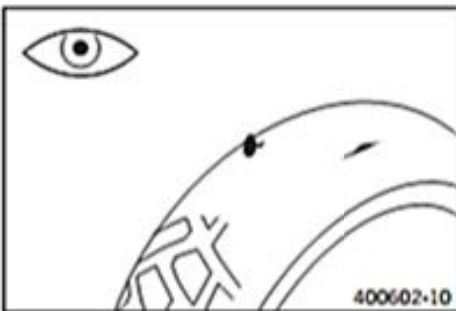

- Check the front and rear tires for cuts, run-in objects and other damage.
 - If the tire exhibits cuts, run-in objects or other damage:
 - Change the tire.
- Check the depth of the tread.

i Info
 Note local national regulations concerning the minimum tread depth.

Minimum tread depth	≥ 2 mm (≥ 0.08 in)
---------------------	--------------------

- If the tread depth is less than the minimum permissible depth:
 - Change the tire.
- Check the tire age.

i Info
 The tire's date of manufacture is usually part of the tire markings and is indicated by the last four digits of the **DOT** marking. The first two digits indicate the week of manufacture and the last two digits the year of manufacture.
 KTM recommends that the tires be changed after 5 years at the latest, regardless of the actual state of wear.

- If the tire is older than five years:
 - Change the tire.

13.3 Checking the brake discs

⚠ Warning
Danger of accidents Reduced braking efficiency due to worn brake disc(s).

- Change the worn brake disc(s) without delay.

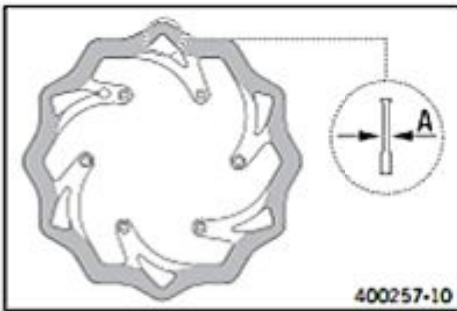

- Check the thickness of the front and rear brake discs at several places on the disk to see if it conforms to measurement **A**.

i Info
Wear reduces the thickness of the brake disc around the area used by the brake linings.

Brake discs - wear limit	
Front	2.5 mm (0.098 in)
Rear	3.5 mm (0.138 in)

- If the brake disc thickness is less than the specified value:
 - Change the brake disc.
- Check the front and rear brake discs for damage, cracking and deformation.
 - If the brake disc shows signs of damage, cracking or deformation:
 - Change the brake disc.

13.4 Checking the spoke tension

Warning
Danger of accidents Instable handling due to incorrect spoke tension.

- Ensure that the spoke tension is correct.

i Info
A loose spoke causes wheel imbalance and rapidly leads to more loose spokes. If the spokes are too tight, they can break due to local overload. Check the spoke tension regularly, especially on a new motorcycle.

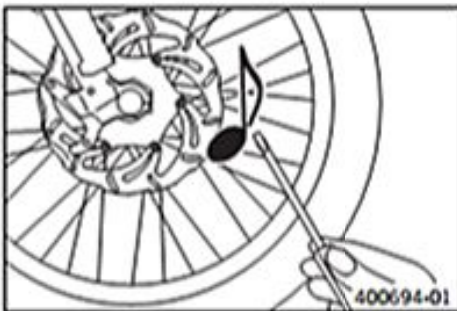

- Briefly strike each spoke with the tip of a screwdriver.

i Info
The tone frequency depends on the length of the spoke and the spoke diameter. If you hear different tone frequencies from different spokes of equal length and diameter, this is an indication of different spoke tensions.

You should hear a high note.

- If the spoke tension varies:
 - Correct the spoke tension.
- Check the spoke torque.

Guideline

Spoke nipple, front wheel	M4.5	6 Nm (4.4 lbf ft)
Spoke nipple, rear wheel	M4.5	6 Nm (4.4 lbf ft)

Torque wrench with various accessories in set (58429094000) (☞ p. 264)

13.5 Front wheel

13.5.1 Removing the front wheel



Preparatory work

- Raise the motorcycle with the lift stand. (☞ p. 10)

Main work

- Press the brake caliper onto the brake disc by hand in order to push back the brake pistons.

i Info
Make sure when pushing back the brake pistons that you do not press the brake caliper against the spokes.



- Loosen screw 1 by several turns.
- Loosen screws 2.
- Press on screw 1 to push the wheel spindle out of the axle clamp.
- Remove screw 1.



- Holding the front wheel, withdraw the wheel spindle. Take the front wheel out of the fork.



Info

Do not pull the hand brake lever when the front wheel is removed. Always lay the wheel down in such a way that the brake disc is not damaged.

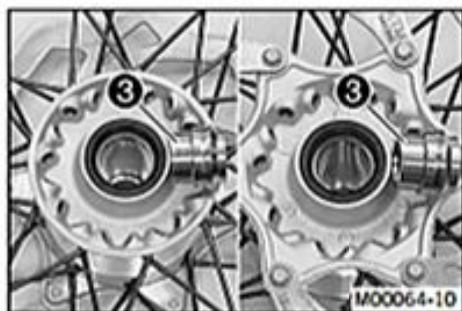

- Remove spacers 3.

13.5.2 Installing the front wheel



Warning

Danger of accidents Reduced braking efficiency due to oil or grease on the brake discs.

- Always keep the brake discs free of oil and grease, and clean them with brake cleaner when necessary.

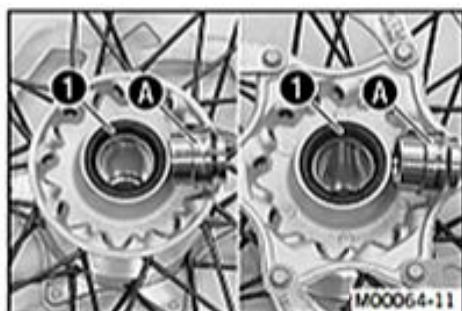

- Check the wheel bearing for damage and wear.
 - If the wheel bearing is damaged or worn:
 - Change the wheel bearing.
- Clean and grease the shaft seal rings 1 and contact surface A of the spacers.

Long-life grease (☛ p. 260)

- Insert the spacers.
- Position the front wheel and insert the wheel spindle.
 - ✓ The brake linings are correctly positioned.
- Mount and tighten screw 2.

Guideline

Screw, front wheel spindle	M20x1.5	35 Nm (25.8 lbf ft)
----------------------------	---------	------------------------

- Activate the hand brake lever multiple times until the brake linings are in contact with the brake disc.
- Remove the motorcycle from the lift stand. (☛ p. 10)
- Pull the front brake and compress the fork powerfully a few times.
 - ✓ The fork legs straighten.
- Tighten screws 3.

Guideline

Screw, fork stub	M8	15 Nm (11.1 lbf ft)
------------------	----	------------------------



13.5.3 Removing the brake disc of the front brake

Preparatory work

- Raise the motorcycle with the lift stand. (☞ p. 10)
- Remove the front wheel. (☞ p. 119)

Main work

- Remove screws ❶. Take off the brake disc.



G01157-10

13.5.4 Installing the brake disc of the front brake

Main work

- Clean the contact surface of the brake disc.
- Position the brake disc with the label facing outward. Mount and tighten screws ❶.

Guideline

Screw, front brake disc	M6	14 Nm (10.3 lbf ft)	Loctite® 243™
-------------------------	----	------------------------	---------------



G01157-10

Finishing work

- Install the front wheel. (☞ p. 120)

13.6 Rear wheel

13.6.1 Removing the rear wheel

Preparatory work

- Raise the motorcycle with the lift stand. (☞ p. 10)

Main work

- Press the brake caliper onto the brake disc by hand in order to push back the brake piston.

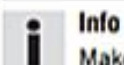

Info

Make sure when pushing back the brake piston that you do not press the brake caliper against the spokes.

- Remove nut ❶.
- Remove chain adjuster ❷. Withdraw wheel spindle ❸ only enough to allow the rear wheel to be pushed forward.
- Push the rear wheel forward as far as possible. Remove the chain from the rear sprocket.



Info

Protect the motorcycle and its attachments against damage by covering them.

- Holding the rear wheel, withdraw the wheel spindle. Take the rear wheel out of the swing arm.

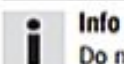

Info

Do not operate the foot brake when the rear wheel is removed. Always lay the wheel down in such a way that the brake disc is not damaged.

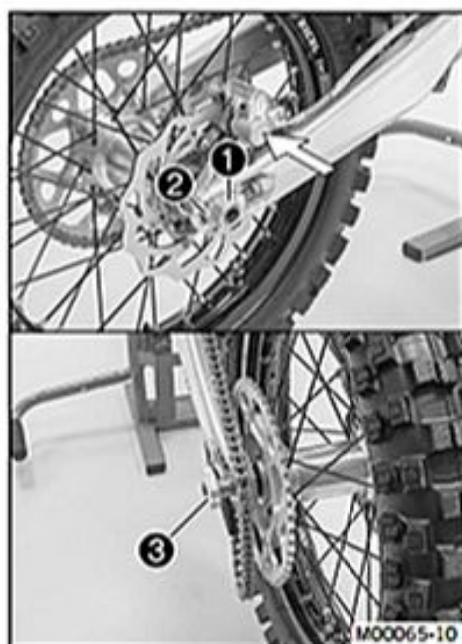

M00065-10

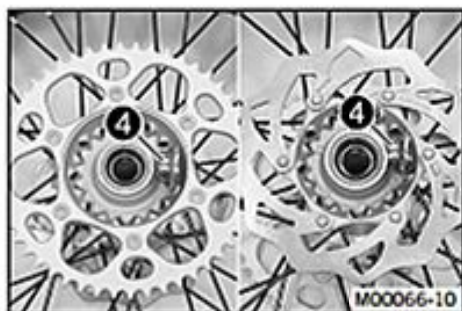

- Remove spacers ④.

13.6.2 Installing the rear wheel



Warning

Danger of accidents Reduced braking efficiency due to oil or grease on the brake discs.

- Always keep the brake discs free of oil and grease, and clean them with brake cleaner when necessary.

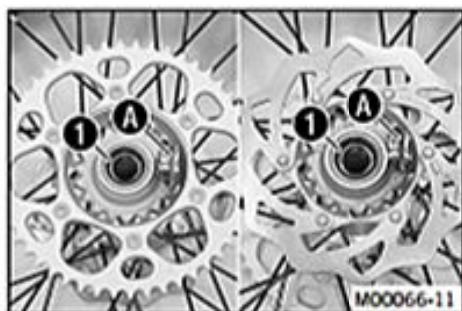

Main work

- Check the wheel bearing for damage and wear.
 - If the wheel bearing is damaged or worn:
 - Change the wheel bearing.
- Clean and grease the shaft seal rings ① and contact surface A of the spacers.

Long-life grease (☛ p. 260)

- Insert the spacers.

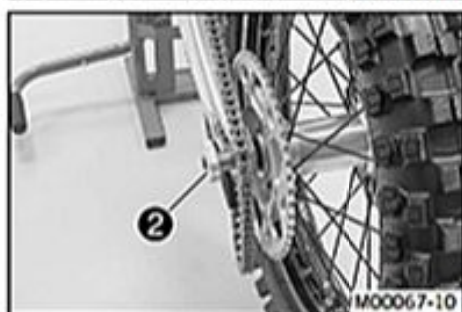

- Position the rear wheel and insert wheel spindle ②.
 - ✓ The brake linings are correctly positioned.
- Put the chain on.

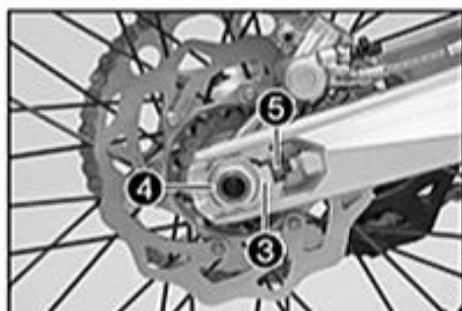

- Position chain adjuster ③. Mount nut ④, but do not tighten it yet.
- Make sure that chain adjusters ③ are fitted correctly on adjusting screws ⑤.
- Check the chain tension. (☛ p. 123)
- Tighten nut ④.

Guideline

Nut, rear wheel spindle	M25x1.5	80 Nm (59 lbf ft)
-------------------------	---------	-------------------



Info

The wide adjustment range of the chain adjusters (32 mm (1.18 in)) enables different secondary ratios with the same chain length. Chain adjusters ③ can be turned by 180°.

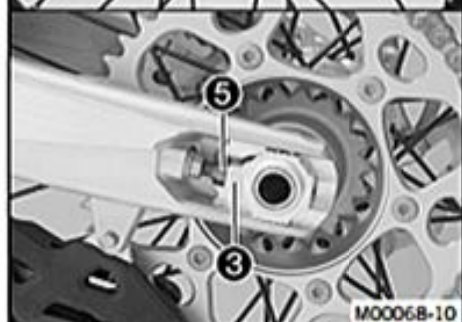

- Operate the foot brake lever repeatedly until the brake linings are in contact with the brake disc and there is a pressure point.

Finishing work

- Remove the motorcycle from the lift stand. (☛ p. 10)

13.6.3 Removing the brake disc of the rear brake



Preparatory work

- Raise the motorcycle with the lift stand. (☞ p. 10)
- Remove the rear wheel. (☞ p. 121)

Main work

- Remove screws **1**. Take off the brake disc.

13.6.4 Installing the brake disc of the rear brake



Main work

- Clean the contact surface of the brake disc.
- Position the brake disc with the label facing outward. Mount and tighten screws **1**.

Guideline

Screw, rear brake disc	M6	14 Nm (10.3 lbf ft)	Loctite® 243™
------------------------	----	------------------------	---------------

Finishing work

- Install the rear wheel. (☞ p. 122)
- Remove the motorcycle from the lift stand. (☞ p. 10)

13.6.5 Checking the chain tension



Warning

Danger of accidents Danger caused by incorrect chain tension.

- If the chain is too taut, the components of the secondary power transmission (chain, engine sprocket, rear sprocket, bearings in the transmission and in the rear wheel) will be under additional load. In addition to premature wear, this can cause the chain or the countershaft of the transmission to break in extreme cases. If the chain is too loose, however, it may fall off the engine sprocket or rear sprocket and block the rear wheel or damage the engine. Ensure that the chain tension is correct and adjust it if necessary.



Preparatory work

- Raise the motorcycle with the lift stand. (☞ p. 10)

Main work

- Pull the chain at the end of the chain sliding component upwards to measure chain tension **A**.



Info

The lower chain section **1** must be taut. Chain wear is not always even, so you should repeat this measurement at different chain positions.

Chain tension	55... 58 mm (2.17... 2.28 in)
---------------	-------------------------------

- If the chain tension does not meet specifications:
 - Adjust the chain tension. (☞ p. 124)

Finishing work

- Remove the motorcycle from the lift stand. (☞ p. 10)

13.6.6 Adjusting the chain tension

Warning
Danger of accidents Danger caused by incorrect chain tension.

- If the chain is too taut, the components of the secondary power transmission (chain, engine sprocket, rear sprocket, bearings in the transmission and in the rear wheel) will be under additional load. In addition to premature wear, this can cause the chain or the countershaft of the transmission to break in extreme cases. If the chain is too loose, however, it may fall off the engine sprocket or rear sprocket and block the rear wheel or damage the engine. Ensure that the chain tension is correct and adjust it if necessary.

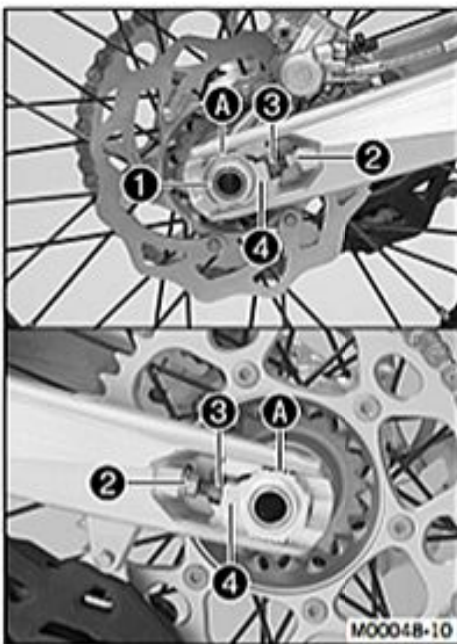

Preparatory work

- Raise the motorcycle with the lift stand. (☛ p. 10)
- Check the chain tension. (☛ p. 123)

Main work

- Loosen nut ①.
- Loosen nuts ②.
- Adjust the chain tension by turning adjusting screws ③ left and right.

Guideline

Chain tension	55... 58 mm (2.17... 2.28 in)
Turn adjusting screws ③ on the left and right so that the markings on the left and right chain adjusters are in the same position relative to reference marks A. The rear wheel is then correctly aligned.	

- Tighten nuts ②.
- Make sure that chain adjusters ④ are fitted correctly on adjusting screws ③.
- Tighten nut ①.

Guideline

Nut, rear wheel spindle	M25x1.5	80 Nm (59 lbf ft)
-------------------------	---------	-------------------

i Info
 The wide adjustment range of the chain adjusters (32 mm (1.18 in)) enables different secondary ratios with the same chain length. Chain adjusters ④ can be turned by 180°.

Finishing work

- Remove the motorcycle from the lift stand. (☛ p. 10)

13.6.7 Checking the chain, rear sprocket, engine sprocket, and chain guide

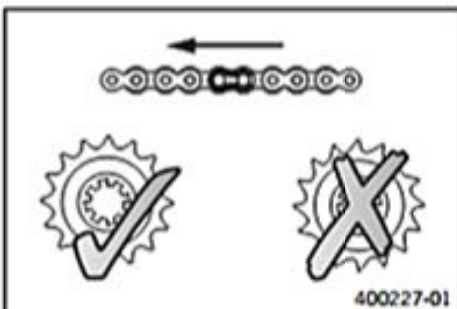

Preparatory work

- Raise the motorcycle with the lift stand. (☛ p. 10)

Main work

- Shift gear to neutral.
- Check the rear sprocket and engine sprocket for wear.
 - If the rear sprocket or engine sprocket are worn:
 - Change the power set.

i Info
 The engine sprocket, rear sprocket, and chain should only be replaced together.

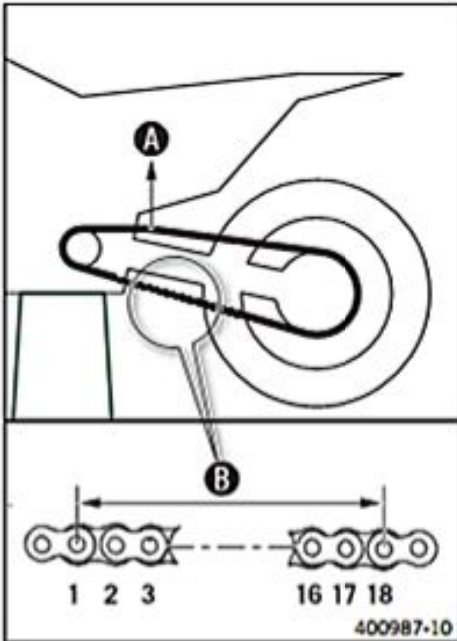

- Pull at the top part of the chain with the specified weight **A**.

Guideline

Weight, chain wear measurement	10... 15 kg (22... 33 lb.)
--------------------------------	----------------------------

- Measure distance **B** of 18 chain rollers on the lower chain section.

i Info

Chains do not always wear evenly, which is why the measurement should be repeated at several locations on the chain.

Maximum distance B on the longest part of the chain	272 mm (10.71 in)
--	-------------------

- If the distance **B** is larger than the specified length:

- Change the power set.

i Info

When a new chain is mounted, the rear sprocket and engine sprocket should be changed as well. New chains wear more rapidly on old, worn rear sprockets and engine sprockets.

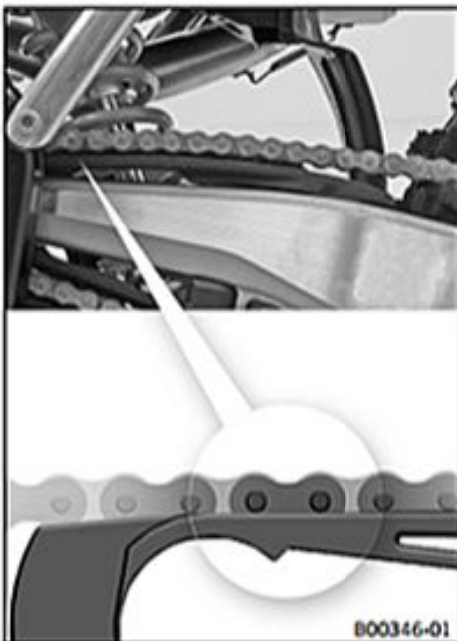

- Check the chain sliding guard for wear.
 - If the lower edge of the chain pin is at the level of or below the chain sliding guard:
 - Change the chain sliding guard.
- Check that the chain sliding guard is firmly seated.
 - If the chain sliding guard is loose:
 - Tighten the chain sliding guard.

Guideline

Screw, chain sliding guard	M6	6 Nm (4.4 lbf ft)	Loctite® 243™
----------------------------	----	-------------------	---------------



- Check the chain sliding piece for wear.
 - If the lower edge of the chain pin is at the level of or below the chain sliding piece:
 - Change the chain sliding piece.
- Check that the chain sliding piece is firmly seated.
 - If the chain sliding piece is loose:
 - Tighten the chain sliding piece.

Guideline

Screw, chain sliding piece	M8	15 Nm (11.1 lbf ft)
----------------------------	----	---------------------



- Check the chain guide for wear.



Info

The wear can be found on the front of the chain guide.

- If the light part of the chain guide is worn:
 - Change the chain guide.



- Check that the chain guide is firmly seated.
 - If the chain guide is loose:
 - Tighten the chain guide.

Guideline

Remaining screws, chassis	M6	10 Nm (7.4 lbf ft)
---------------------------	----	-----------------------

Finishing work

- Remove the motorcycle from the lift stand. (☛ p. 10)

13.6.8 Checking for chain dirt accumulation

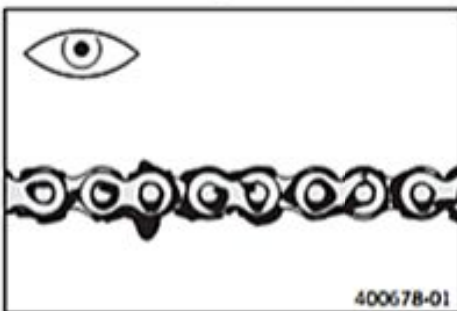

- Check the chain for coarse dirt accumulation.
 - If the chain is very dirty:
 - Clean the chain. (☛ p. 126)

13.6.9 Cleaning the chain



Warning

Danger of accidents Oil or grease on the tires reduces their grip.

- Remove oil and grease with a suitable cleaning material.



Warning

Danger of accidents Reduced braking efficiency due to oil or grease on the brake discs.

- Always keep the brake discs free of oil and grease, and clean them with brake cleaner when necessary.



Warning

Environmental hazard Hazardous substances cause environmental damage.

- Oil, grease, filters, fuel, cleaners, brake fluid, etc., should be disposed of as stipulated in applicable regulations.



Info

The service life of the chain depends largely on its maintenance.

Preparatory work

- Raise the motorcycle with the lift stand. (☛ p. 10)

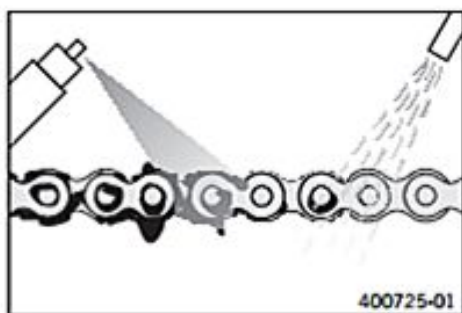

Main work

- Clean the chain regularly and then treat with chain spray.

Chain cleaner (☛ p. 260)

Off-road chain spray (☛ p. 261)

Finishing work

- Remove the motorcycle from the lift stand. (☛ p. 10)

14.1 Changing the main fuse



Warning

Fire hazard The electrical system can be overloaded if the wrong fuses are used.

- Use only fuses with the prescribed amperage. Never by-pass or repair fuses.



Info

The main fuse protects all power consumers of the vehicle. It is located in the starter relay housing under the air filter box lid.

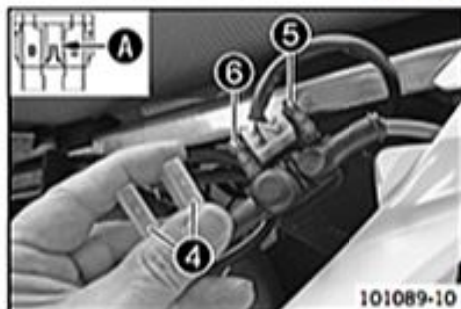

Preparatory work

- Switch off all power consumers and switch off the engine.
- Remove the air filter box lid. (☛ p. 103)

Main work

- Remove screw **1**.

- Lift rear fairing **2** slightly and pull starter relay **3** out of the holder.

- Remove protection caps **4**.
- Remove the faulty main fuse **5**.



Info

A defective fuse can be identified by the burned-out fuse wire **A**.
A reserve fuse **6** is located in the starter relay.

- Install a new main fuse.

Fuse (58011109110) (☛ p. 237)

- Check that the electrical equipment is functioning properly.



Tip

Insert the spare fuse so that it is available if needed.

- Mount the protection caps.
- Mount the starter relay onto the holder and lay the cable.
- Position the rear fairing. Mount and tighten the screw.

Guideline

Remaining screws, chassis	M6	10 Nm (7.4 lbf ft)
---------------------------	----	--------------------

Finishing work

- Install the air filter box lid. (☛ p. 103)

14.2 Removing the battery

Warning
Risk of injury Battery acid and battery gases cause serious chemical burns.

- Keep batteries out of the reach of children.
- Wear suitable protective clothing and goggles.
- Avoid contact with battery acid and battery gases.
- Keep sparks and open flames away from the battery. Only charge in well-ventilated rooms.
- In the event of skin contact, rinse with large amounts of water. If battery acid gets in the eyes, rinse with water for at least 15 minutes and contact a physician.

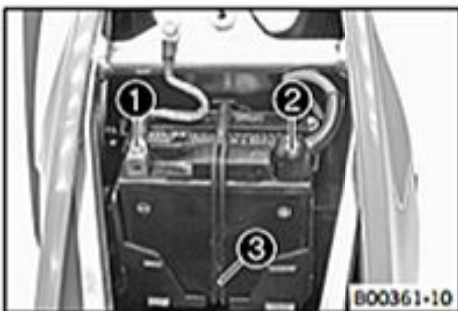

Preparatory work

- Switch off all power consumers and switch off the engine.
- Remove the seat. (☛ p. 107)

Main work

- Disconnect negative cable ① of the battery.
- Pull back the positive terminal cover ② and disconnect the positive (plus) cable of the battery.
- Detach rubber band ③ at the bottom.
- Lift the battery up and out.

14.3 Installing the battery

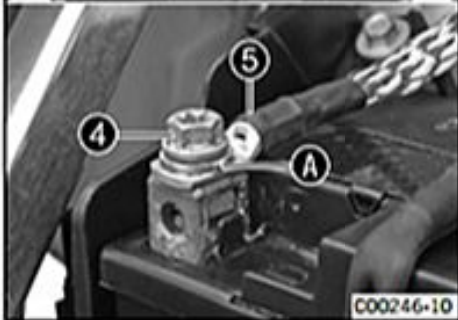
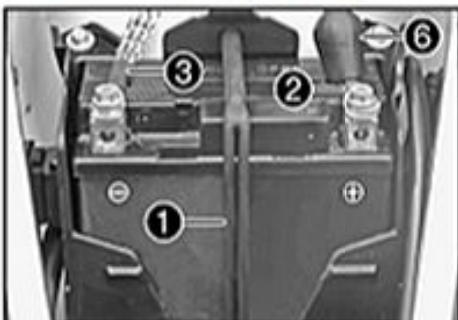

Main work

- Insert the battery into the battery compartment with the terminals facing to the front.

(SX-F EU, SX-F USA)
 Battery (YTX4L-BS) (☛ p. 237)

(XC-F)
 Battery (YTX5L-BS) (☛ p. 237)

- Reconnect rubber band ①.
- Connect positive cable ② and negative cable ③.

Guideline

Screw, battery terminal	M5	2.5 Nm (1.84 lbf ft)
-------------------------	----	-------------------------

Info
 Contact disks A must be mounted between screws ④ and cable sockets ⑤ with the claws facing down.

- Slide positive terminal cover ⑥ over the positive terminal.

Finishing work

- Mount the seat. (☛ p. 107)

14.4 Charging the battery

Warning
Risk of injury Battery acid and battery gases cause serious chemical burns.

- Keep batteries out of the reach of children.
- Wear suitable protective clothing and goggles.
- Avoid contact with battery acid and battery gases.
- Keep sparks and open flames away from the battery. Only charge in well-ventilated rooms.
- In the event of skin contact, rinse with large amounts of water. If battery acid gets in the eyes, rinse with water for at least 15 minutes and contact a physician.



Warning

Environmental hazard The battery contains elements that are harmful to the environment.

- Do not discard batteries with the household waste. Dispose of faulty batteries in an environmentally compatible manner. Give the battery to your authorized KTM dealer or dispose of it at a collection point for used batteries.



Warning

Environmental hazard Hazardous substances cause environmental damage.

- Oil, grease, filters, fuel, cleaners, brake fluid, etc., should be disposed of as stipulated in applicable regulations.



Info

Even when there is no load on the battery, it still loses power steadily. The charging level and the method of charging are very important for the service life of the battery. Rapid recharging with a high charging current shortens the battery's service life. If the charging current, charging voltage and charging time are exceeded, electrolyte escapes through the safety valves. This reduces the battery capacity. If the battery is depleted from starting the vehicle repeatedly, the battery must be charged immediately. If the battery is left in a discharged state for an extended period, it will become over-discharged and sulfate, destroying the battery. The battery is maintenance-free, which means that the acid level does not need to be checked.



Preparatory work

- Switch off all power consumers and switch off the engine.
- Remove the seat. (☛ p. 107)
- Disconnect the negative cable of the battery to avoid damage to the onboard electronics.

Main work

- Connect the battery charger to the battery. Switch on the battery charger.

Battery charger (58429074000)

You can also use the battery charger to test the open-circuit voltage and starting voltage of the battery, and to test the alternator. With this device, you cannot over-charge the battery.



Info

Never remove lid ①. Charge the battery with a maximum of 10% of the capacity specified on the battery housing ②.

- Switch off the battery charger after charging. Disconnect the battery.

Guideline

The charge current, charge voltage and charge time must not be exceeded.

Charge the battery regularly when the motorcycle is not in use	3 months
--	----------

Finishing work

- Mount the seat. (☛ p. 107)

14.5 Checking the charging voltage

Condition

The battery must be fully functional and completely charged.

Preparatory work

- Remove the seat. (☛ p. 107)

Main work

- Pull back the positive terminal cover.
- Start the motorcycle for a check. (☛ p. 11)
- **V** Measure the voltage between the specified points. Measuring point **Plus (+)** – Measuring point **Ground (-)**

Charging voltage

5,000 rpm	13.5... 15.0 V
-----------	----------------



- If the displayed value is less than the specified value:
 - Check the plug-in connections from the alternator to the voltage regulator.
 - Check the plug-in connections from the voltage regulator to the wiring harness.
 - Check the stator winding of the alternator. (☛ p. 230)
- If the displayed value is greater than the specified value:
 - Change the voltage regulator.

Finishing work

- Mount the seat. (☛ p. 107)

14.6 Checking the quiescent current

Preparatory work

- Switch off all power consumers and switch off the engine.
- Remove the seat. (☛ p. 107)

Main work

- Disconnect the negative cable from the battery.
- Measure the current between battery ground (-) and the negative cable.



Info

The value of the quiescent current applies only to vehicles in the original state, i.e. without additional power consumers.

Maximum quiescent current	< 1.0 mA
---------------------------	----------

- If the measured value is higher than the specified value:
 - Disconnect the voltage regulator from the wiring harness and perform the measurement again.
 - Check the capacitor. (☛ p. 131)

Finishing work

- Mount the seat. (☛ p. 107)

14.7 Checking the capacitor

Condition

The battery is disconnected.

- Remove the capacitor.
- Discharge the capacitor by bridging the two contacts.
- Connect the capacitor with a 12 V test lamp on one connector and connect it to the battery as shown in the figure.

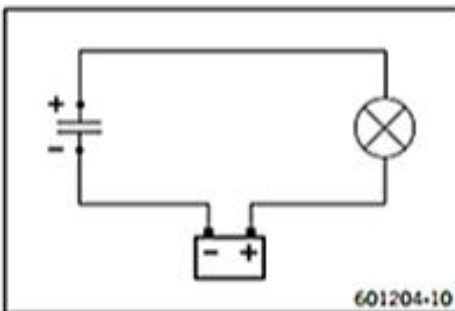

Info

As the charge of the capacitor increases, the test lamp becomes dimmer.

- The lamp lights up for: 0.5... 2.0 s
The capacitor is functional.
 - The lamp lights up for: < 0.5 s
Change the capacitor.
 - The lamp lights up for: > 2.0 s
Change the capacitor.
- Discharge the capacitor with a 12 V test lamp as shown in the figure.

Info

As the charge of the capacitor decreases, the test lamp becomes dimmer.

- The lamp lights up for: 0.5... 2.0 s
The capacitor is functional.
- The lamp lights up for: < 0.5 s
Change the capacitor.
- The lamp lights up for: > 2.0 s
Change the capacitor.

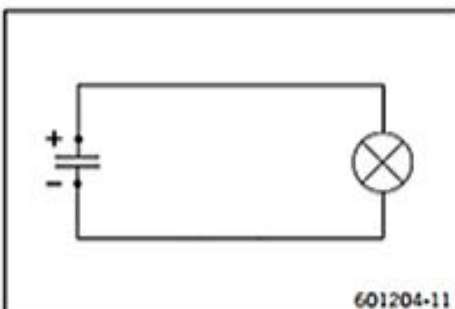

- Install the capacitor.

14.8 Checking the starter relay

Preparatory work

- Switch off all power consumers and switch off the engine.
- Remove the seat. (☞ p. 107)
- Remove the air filter box lid. (☞ p. 103)

Main work

- Remove screw ❶.



- Lift rear fairing ❷ slightly and pull starter relay ❸ out of the holder.



- Disconnect the negative cable of the battery.
- Pull off connector ❹.
- Pull back covers ❺ and ❻.

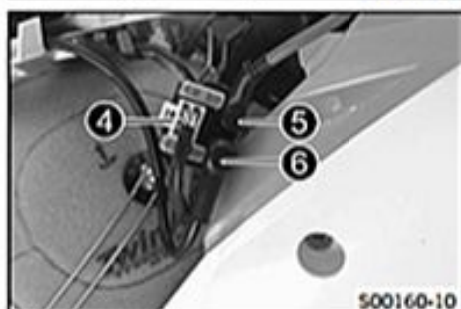

- Disconnect cables ❼ and ❽ on the starter relay.

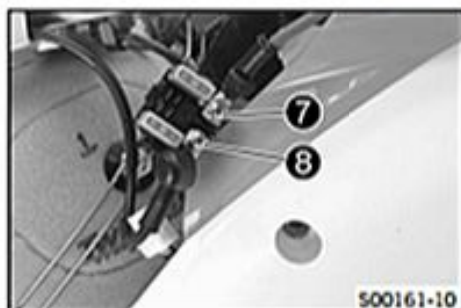

- Connect the starter relay to a 12 V power supply as shown.
- Measure the resistance between the specified points.

Resistance of open circuit	0 Ω
----------------------------	-----

- If the value displayed does not meet specifications:
 - Change the starter relay.

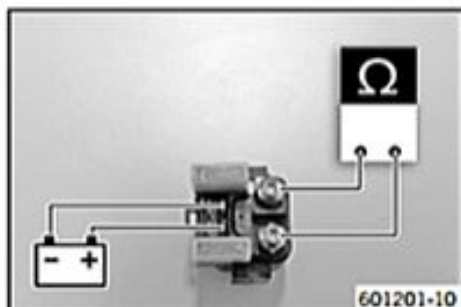

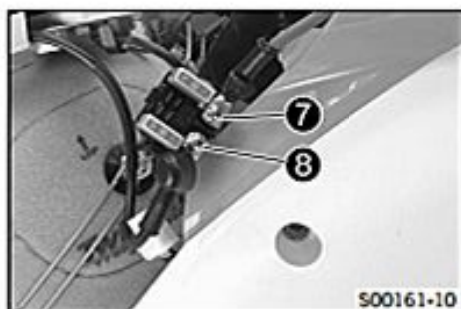

- Connect cables 7 and 8 to the starter relay.

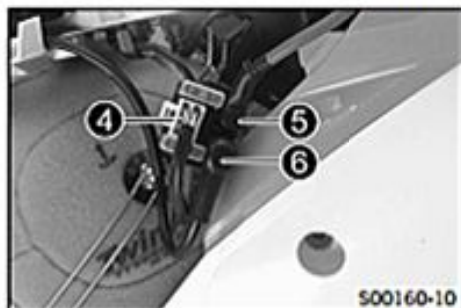

- Slide covers 5 and 6 over the cables on the starter relay.
- Pull off connector 4.
- Disconnect the negative cable of the battery.



- Mount starter relay 3 on the holder 2 and route the cable.



- Position the rear fairing. Mount and tighten screw 1.

Guideline

Remaining screws, chassis	M6	10 Nm (7.4 lbf ft)
---------------------------	----	--------------------

Finishing work

- Install the air filter box lid. (☞ p. 103)
- Mount the seat. (☞ p. 107)

15.1 Checking the front brake linings

- Warning**
Danger of accidents Reduced braking efficiency caused by worn brake linings.
- Change worn brake linings immediately.

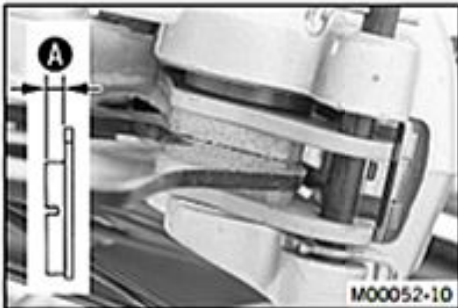

- Check the brake linings for minimum thickness **A**.

Minimum thickness A	≥ 1 mm (≥ 0.04 in)
----------------------------	--------------------

- If the minimum thickness is less than specified:
 - Change the front brake linings. (☛ p. 134)
- Check the brake linings for damage and cracking.
 - If damage or cracking is visible:
 - Change the front brake linings. (☛ p. 134)

15.2 Changing the front brake linings

- Warning**
Danger of accident Brake system failure.
- Maintenance work and repairs must be carried out professionally.

- Warning**
Skin irritation Brake fluid can cause skin irritation on contact.
- Avoid contact with skin and eyes, and keep out of the reach of children.
 - Wear suitable protective clothing and goggles.
 - If brake fluid comes into contact with the eyes, flush the eyes thoroughly with water and consult a physician immediately.

- Warning**
Danger of accidents Reduced braking efficiency due to old brake fluid.
- Change the brake fluid of the front and rear brake according to the service schedule.

- Warning**
Environmental hazard Hazardous substances cause environmental damage.
- Oil, grease, filters, fuel, cleaners, brake fluid, etc., should be disposed of as stipulated in applicable regulations.

- i Info**
 Never use DOT 5 brake fluid! It is silicone-based and purple in color. Oil seals and brake lines are not designed for DOT 5 brake fluid.
 Avoid contact between brake fluid and painted parts. Brake fluid attacks paint!
 Use only clean brake fluid from a sealed container.



- Move the brake fluid reservoir mounted on the handlebar to a horizontal position.
- Remove screws **1**.
- Remove cover **2** with membrane **3**.

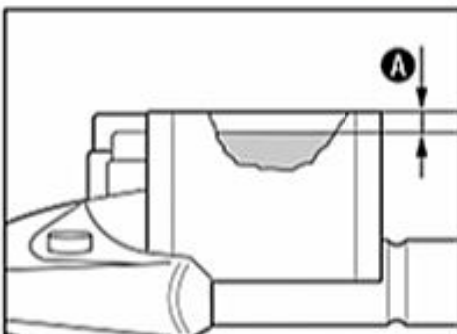
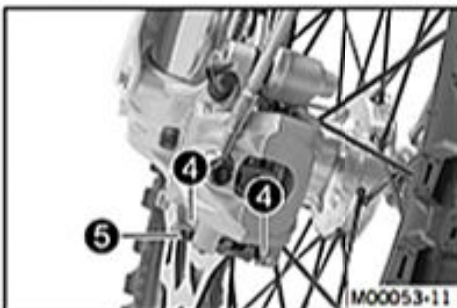
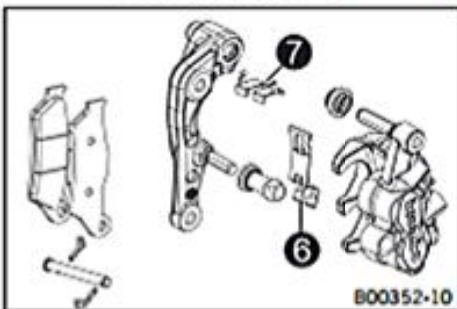
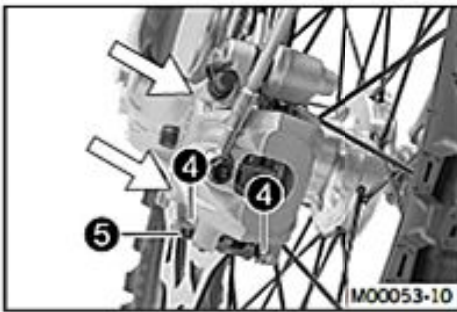

- Manually press the brake caliper to the brake disc to push back the brake pistons. Ensure that brake fluid does not flow out of the brake fluid reservoir, extracting it by suction if it does.

i Info
Make sure when pushing back the brake pistons that you do not press the brake caliper against the spokes.

- Remove cotter pins (4), pull out pin (5), and remove the brake linings.
- Clean the brake caliper and brake caliper support.
- Check that leaf spring (6) in the brake caliper and sliding plate (7) in the brake caliper support are seated correctly.

- Insert the new brake linings, insert pin (5), and mount cotter pins (4).

i Info
Always change the brake linings in pairs.

- Operate the hand brake lever repeatedly until the brake linings are in contact with the brake disc and there is a pressure point.

- Add brake fluid to level (A).

Guideline

Dimension (A) (brake fluid level below top edge of container)	5 mm (0.2 in)
---	---------------

Brake fluid DOT 4 / DOT 5.1 (☞ p. 258)

- Position cover (2) with membrane (3).
- Mount and tighten screws (1).

i Info
Clean up overflowed or spilt brake fluid immediately with water.

15.3 Checking the free travel of the hand brake lever

Warning
Danger of accidents Brake system failure.

- If there is no free travel on the hand brake lever, pressure builds up on the front brake circuit. The front brake can fail due to overheating. Adjust the free travel on hand brake lever according to specifications.



- Push the hand brake lever forward and check free travel **A**.

Free travel of hand brake lever	≥ 3 mm (≥ 0.12 in)
---------------------------------	--------------------

- If the free travel does not meet specifications:
 - Adjust the basic position of the hand brake lever. (☞ p. 136)

15.4 Adjusting the basic position of the hand brake lever



Preparatory work

- Check the free travel of the hand brake lever. (☞ p. 135)

Main work

- Adjust the basic setting of the hand brake lever to your hand size by turning adjusting screw **1**.

Info

Turn the adjusting screw clockwise to increase the distance between the hand brake lever and the handlebar.
 Turn the adjusting screw counterclockwise to decrease the distance between the hand brake lever and the handlebar.
 The range of adjustment is limited.
 Turn the adjusting screw by hand only, and do not apply any force.
 Do not make any adjustments while riding!

15.5 Checking the brake fluid level of the front brake

Warning

Danger of accidents Brake system failure.

- If the brake fluid level drops below the specified marking or the specified value, this is an indication that the brake system is leaking or that the brake linings are completely worn down. Check the brake system and do not continue riding.

Warning

Danger of accidents Reduced braking efficiency due to old brake fluid.

- Change the brake fluid of the front and rear brake according to the service schedule.



Preparatory work

- Check the front brake linings. (☞ p. 134)

Main work

- Move the brake fluid reservoir mounted on the handlebar to a horizontal position.
- Check the brake fluid level in level viewer **1**.
 - If the brake fluid level has dropped below marking **A**:
 - Add front brake fluid. (☞ p. 137)

15.6 Adding front brake fluid

Warning
Danger of accidents Brake system failure.

- If the brake fluid level drops below the specified marking or the specified value, this is an indication that the brake system is leaking or that the brake linings are completely worn down. Check the brake system and do not continue riding.

Warning
Skin irritation Brake fluid can cause skin irritation on contact.

- Avoid contact with skin and eyes, and keep out of the reach of children.
- Wear suitable protective clothing and goggles.
- If brake fluid comes into contact with the eyes, flush the eyes thoroughly with water and consult a physician immediately.

Warning
Danger of accidents Reduced braking efficiency due to old brake fluid.

- Change the brake fluid of the front and rear brake according to the service schedule.

Warning
Environmental hazard Hazardous substances cause environmental damage.

- Oil, grease, filters, fuel, cleaners, brake fluid, etc., should be disposed of as stipulated in applicable regulations.

i Info
 Never use DOT 5 brake fluid. It is silicone-based and purple in color. Oil seals and brake lines are not designed for DOT 5 brake fluid.
 Avoid contact between brake fluid and painted parts. Brake fluid attacks paint!
 Use only clean brake fluid from a sealed container.

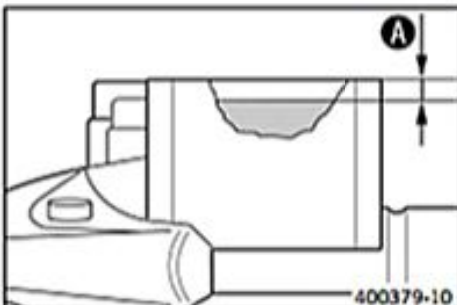

Preparatory work

- Check the front brake linings. (☛ p. 134)

Main work

- Move the brake fluid reservoir mounted on the handlebar to a horizontal position.
- Remove screws **1**.
- Remove cover **2** with membrane **3**.

- Add brake fluid to level **A**.

Guideline

Level A (brake fluid level below container rim)	5 mm (0.2 in)
--	---------------

Brake fluid DOT 4 / DOT 5.1 (☛ p. 258)

- Position cover **2** with membrane **3**. Mount and tighten screws **1**.

i Info
 Clean up overflowed or spilled brake fluid immediately with water.

15.7 Changing the front brake fluid

- Warning**
Skin irritation Brake fluid can cause skin irritation on contact.
- Avoid contact with skin and eyes, and keep out of the reach of children.
 - Wear suitable protective clothing and goggles.
 - If brake fluid comes into contact with the eyes, flush the eyes thoroughly with water and consult a physician immediately.

- Warning**
Environmental hazard Hazardous substances cause environmental damage.
- Oil, grease, filters, fuel, cleaners, brake fluid, etc., should be disposed of as stipulated in applicable regulations.

- Info**
 Avoid contact between brake fluid and painted parts. Brake fluid attacks paint!
 Use only clean brake fluid from a sealed container.

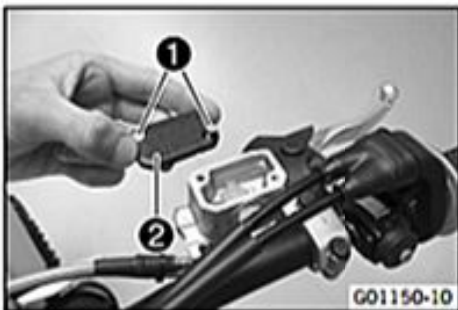

- Move the brake fluid reservoir mounted on the handlebar to a horizontal position.
- Cover the painted parts.
- Remove screws ①.
- Remove cover ② with the membrane.
- Draw the old brake fluid out of the brake fluid reservoir using a syringe and fill with fresh brake fluid.

Bleed syringe (50329050000) (☞ p. 263)
Brake fluid DOT 4 / DOT 5.1 (☞ p. 258)



- Mount bleeder cover ③.
- Connect the bleeding device.

Bleeder cover (00029013005) (☞ p. 262)
Bleeding device (00029013100) (☞ p. 262)

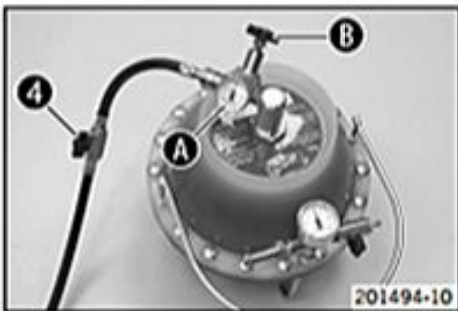

- Open shut-off valve ④.
- Info**
 Follow the operating instructions of the bleeding device.
- Ensure that the filling pressure is set on pressure gauge A. Adjust the filling pressure on pressure regulator B if necessary.

Guideline

Filling pressure	2... 2.5 bar (29... 36 psi)
------------------	-----------------------------

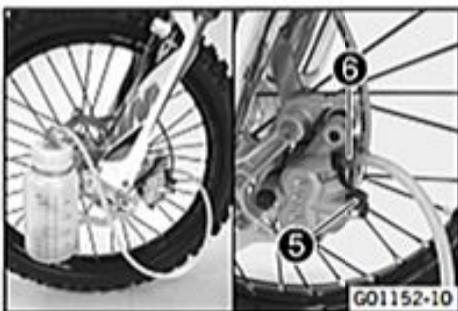

- Pull off protection cap ⑤ of the brake caliper bleeder screw. Connect the hose of the bleeder bottle.
- Open bleeder screw ⑥ by approx. one-half turn.

Bleeding device (00029013100) (☞ p. 262)
--

- Info**
 Drain until the fresh brake fluid emerges from the hose of the bleeder bottle without bubbles.

- Tighten the bleeder screw.
- Close shut-off valve ④.

- Open the bleeder screw again until brake fluid stops emerging.



Info
This prevents overfilling of the brake fluid reservoir.

- Tighten the bleeder screw. Remove the hose of the bleeder bottle. Mount the protection cap.
- Lock the bleeding device. Remove the bleeder cover.
- Correct the brake fluid to level **C**.

Guideline

Level C (brake fluid level below container rim)	5 mm (0.2 in)
--	---------------

Brake fluid DOT 4 / DOT 5.1 (☞ p. 258)

- Position the cover with the membrane. Mount and tighten the screws.



Info
Clean up overflowed or spilt brake fluid immediately with water.

- Check the hand brake lever for a firm pressure point.

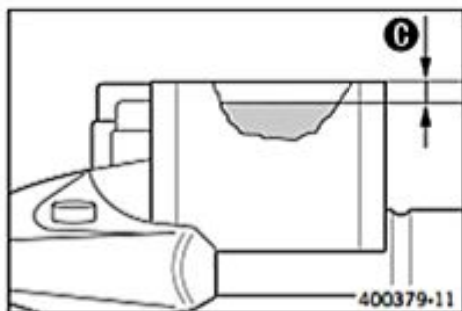

15.8 Checking the rear brake linings



Warning

Danger of accidents Reduced braking efficiency caused by worn brake linings.

- Change worn brake linings immediately.



- Check the brake linings for minimum thickness **A**.

Minimum thickness A	≥ 1 mm (≥ 0.04 in)
----------------------------	--------------------

- If the minimum thickness is less than specified:
 - Change the rear brake linings. (☞ p. 139)
- Check the brake linings for damage and cracking.
 - If damage or cracking is visible:
 - Change the rear brake linings. (☞ p. 139)

15.9 Changing the rear brake linings



Warning

Danger of accident Brake system failure.

- Maintenance work and repairs must be carried out professionally.



Warning

Skin irritation Brake fluid can cause skin irritation on contact.

- Avoid contact with skin and eyes, and keep out of the reach of children.
- Wear suitable protective clothing and goggles.
- If brake fluid comes into contact with the eyes, flush the eyes thoroughly with water and consult a physician immediately.



Warning

Danger of accidents Reduced braking efficiency due to old brake fluid.

- Change the brake fluid of the front and rear brake according to the service schedule.



Warning

Environmental hazard Hazardous substances cause environmental damage.

- Oil, grease, filters, fuel, cleaners, brake fluid, etc., should be disposed of as stipulated in applicable regulations.

i Info

Never use DOT 5 brake fluid! It is silicone-based and purple in color. Oil seals and brake lines are not designed for DOT 5 brake fluid.

Avoid contact between brake fluid and painted parts. Brake fluid attacks paint!

Use only clean brake fluid from a sealed container.

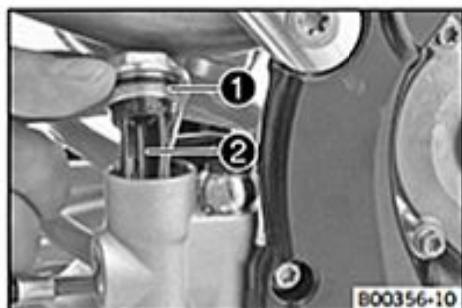

- Stand the vehicle upright.
- Remove screw cap ① with membrane ② and the O-ring.

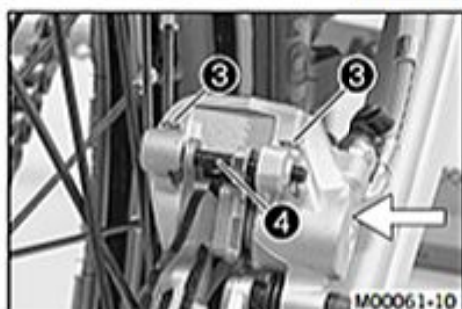

- Manually press the brake caliper to the brake disc to push back the brake piston. Ensure that brake fluid does not flow out of the brake fluid reservoir, extracting it by suction if it does.

i Info

Make sure when pushing back the brake piston that you do not press the brake caliper against the spokes.

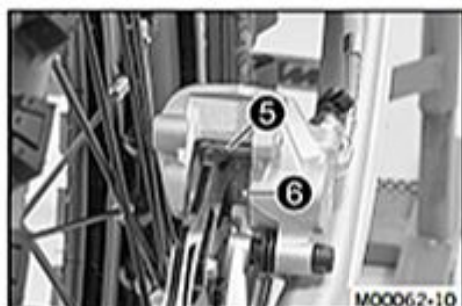

- Remove cotter pins ③, pull out pin ④, and remove the brake linings.
- Clean the brake caliper and brake caliper support.
- Check that leaf spring ⑤ in the brake caliper and sliding plate ⑥ in the brake caliper support are seated correctly.

i Info

The arrow on the leaf spring points in the rotation direction of the brake disc.

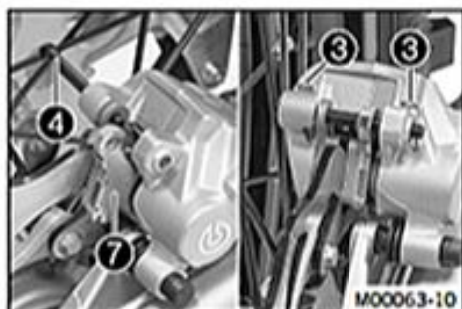

- Insert the new brake linings, insert pin ④, and mount cotter pins ③.

i Info

Always change the brake linings in pairs.
Make sure that the decoupling plate ⑦ is mounted on the piston side of the brake lining.

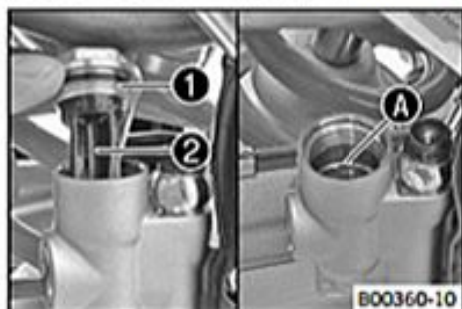

- Operate the foot brake lever repeatedly until the brake linings are in contact with the brake disc and there is a pressure point.
- Add brake fluid to level A.

Brake fluid DOT 4 / DOT 5.1 (↔ p. 258)

- Mount and tighten screw cap ① with membrane ② and the O-ring.

i Info

Clean up overflowed or spilt brake fluid immediately with water.

15.10 Checking the free travel of foot brake lever

Warning
Danger of accidents Brake system failure.

- If there is no free travel on the foot brake lever, pressure builds up on the rear brake circuit. The rear brake can fail due to overheating. Adjust the free travel on foot brake lever according to specifications.

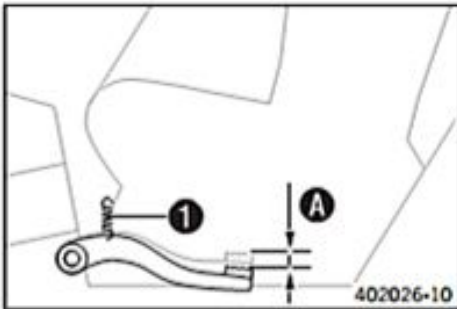

- Disconnect spring ①.
- Move the foot brake lever back and forth between the end stop and the contact to the foot brake cylinder piston and check free travel A.

Guideline

Free travel at foot brake lever	3... 5 mm (0.12... 0.2 in)
---------------------------------	----------------------------

- If the free travel does not meet specifications:
 - Adjust the basic position of the foot brake lever. (↔ p. 141)
- Reconnect spring ①.

15.11 Adjusting the basic position of the foot brake lever

Warning
Danger of accidents Brake system failure.

- If there is no free travel on the foot brake lever, pressure builds up on the rear brake circuit. The rear brake can fail due to overheating. Adjust the free travel on foot brake lever according to specifications.

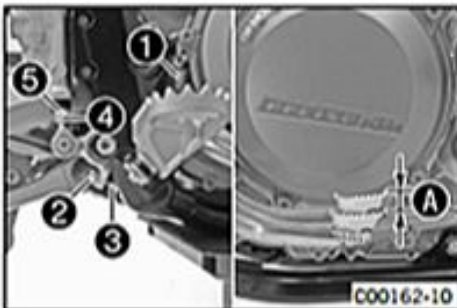

- Disconnect spring ①.
- Loosen nut ④ and, with push rod ⑤, turn it back until you have maximum free travel.
- To adjust the basic position of the foot brake lever individually, loosen nut ② and turn screw ③ accordingly.

i Info
 The range of adjustment is limited.

- Turn push rod ⑤ accordingly until you have free travel A. If necessary, adjust the basic position of the foot brake lever.

Guideline

Free travel at foot brake lever	3... 5 mm (0.12... 0.2 in)
---------------------------------	----------------------------

- Hold screw ③ and tighten nut ②.

Guideline

Nut, foot brake lever stop	M8	20 Nm (14.8 lbf ft)
----------------------------	----	------------------------

- Hold push rod ⑤ and tighten nut ④.

Guideline

Remaining nuts, chassis	M6	10 Nm (7.4 lbf ft)
-------------------------	----	--------------------

- Reconnect spring ①.

15.12 Checking the rear brake fluid level

Warning
Danger of accidents Brake system failure.

- If the brake fluid level drops below the specified marking or the specified value, this is an indication that the brake system is leaking or that the brake linings are completely worn down. Check the brake system and do not continue riding.

Warning
Danger of accidents Reduced braking efficiency due to old brake fluid.

- Change the brake fluid of the front and rear brake according to the service schedule.

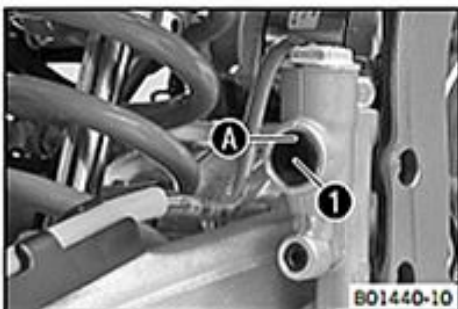
**Preparatory work**

- Check the rear brake linings. (☞ p. 139)

Main work

- Stand the vehicle upright.
- Check the brake fluid level in the viewer **1**.
 - If the brake fluid level drops below marking **A**:
 - Add rear brake fluid. (☞ p. 142)

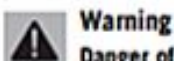
15.13 Adding rear brake fluid**Warning**

Danger of accidents Brake system failure.

- If the brake fluid level drops below the specified marking or the specified value, this is an indication that the brake system is leaking or that the brake linings are completely worn down. Check the brake system and do not continue riding.

**Warning**

Skin irritation Brake fluid can cause skin irritation on contact.

- Avoid contact with skin and eyes, and keep out of the reach of children.
- Wear suitable protective clothing and goggles.
- If brake fluid comes into contact with the eyes, flush the eyes thoroughly with water and consult a physician immediately.

**Warning**

Danger of accidents Reduced braking efficiency due to old brake fluid.

- Change the brake fluid of the front and rear brake according to the service schedule.

**Warning**

Environmental hazard Hazardous substances cause environmental damage.

- Oil, grease, filters, fuel, cleaners, brake fluid, etc., should be disposed of as stipulated in applicable regulations.

**Info**

Never use DOT 5 brake fluid! It is silicone-based and purple in color. Oil seals and brake lines are not designed for DOT 5 brake fluid.

Avoid contact between brake fluid and painted parts. Brake fluid attacks paint!

Use only clean brake fluid from a sealed container.

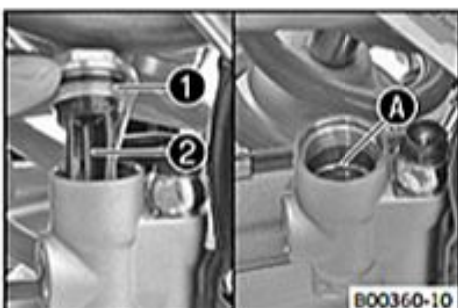
**Preparatory work**

- Check the rear brake linings. (☞ p. 139)

Main work

- Stand the vehicle upright.
- Remove screw cap **1** with membrane **2** and the O-ring.
- Add brake fluid to level **A**.

Brake fluid DOT 4 / DOT 5.1 (☞ p. 258)

- Mount and tighten the screw cap with the membrane and O-ring.

**Info**

Clean up overflowed or spilt brake fluid immediately with water.

15.14 Changing the rear brake fluid

- Warning**
Skin irritation Brake fluid can cause skin irritation on contact.
- Avoid contact with skin and eyes, and keep out of the reach of children.
 - Wear suitable protective clothing and goggles.
 - If brake fluid comes into contact with the eyes, flush the eyes thoroughly with water and consult a physician immediately.

- Warning**
Environmental hazard Hazardous substances cause environmental damage.
- Oil, grease, filters, fuel, cleaners, brake fluid, etc., should be disposed of as stipulated in applicable regulations.

- i Info**
 Avoid contact between brake fluid and painted parts. Brake fluid attacks paint!
 Use only clean brake fluid from a sealed container.



- Cover the painted parts.
- Remove screw cap 1 with membrane and the O-ring.
- Draw the old brake fluid out of the brake fluid reservoir using a syringe and fill with fresh brake fluid.

Bleed syringe (50329050000) (☞ p. 263)
--

Brake fluid DOT 4 / DOT 5.1 (☞ p. 258)
--



- Mount bleeder cover 2.
- | |
|--|
| Bleeder cover (00029013006) (☞ p. 262) |
|--|

- Connect the bleeding device.

Bleeding device (00029013100) (☞ p. 262)
--

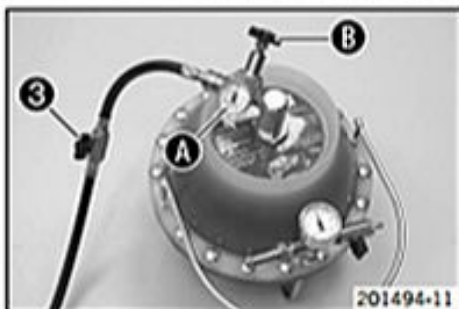

- Open shut-off valve 3.

- i Info**
 Follow the operating instructions of the bleeding device.

- Ensure that the filling pressure is set on pressure gauge A. Adjust the filling pressure on pressure regulator B if necessary.

Guideline

Filling pressure	2... 2.5 bar (29... 36 psi)
------------------	-----------------------------

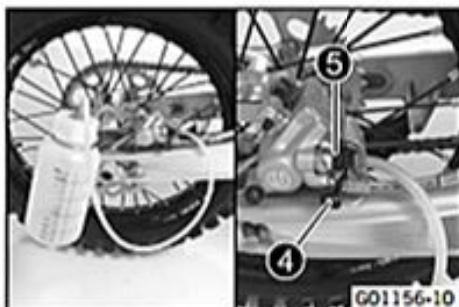

- Pull off protection cap 4 of the bleeder screw. Connect the hose of the bleeder bottle.

Bleeding device (00029013100) (☞ p. 262)
--

- Open bleeder screw 5 by approx. one-half turn.

- i Info**
 Drain until the fresh brake fluid emerges from the hose of the bleeder bottle without bubbles.

- Tighten the bleeder screw.

- Close shut-off valve 3.

- Open the bleeder screw again until brake fluid stops emerging.



Info

This prevents overfilling of the brake fluid reservoir.

- Tighten the bleeder screw. Remove the hose of the bleeder bottle. Mount the protection cap.
- Lock the bleeding device. Remove the bleeder cover.
- Stand the vehicle upright.
- Correct the brake fluid to marking **C**.

Brake fluid DOT 4 / DOT 5.1 (☛ p. 258)

- Mount and tighten the screw cap with the membrane and O-ring.



Info

Clean up overflowed or spilt brake fluid immediately with water.

- Check the foot brake lever for a firm pressure point.



16.1 Removing the engine

Preparatory work

- Raise the motorcycle with the lift stand. (☞ p. 10)
- Drain the coolant. (☞ p. 223)
- Remove the seat. (☞ p. 107)
- Remove the fuel tank. (☞ p. 107)
- Remove the main silencer. (☞ p. 101)

Main work

- Disconnect negative cable ❶ of the battery.

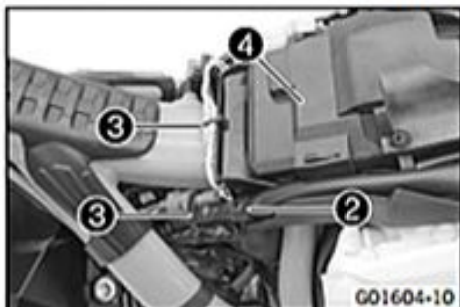

- Open cable holder ❷. Remove cable binder ❸.
- Pull the EFI control unit ❹ from the holder and hang it to one side.

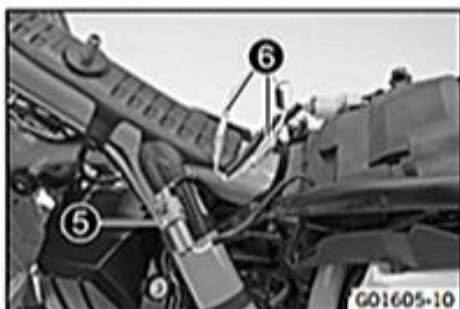

- Disconnect plug-in connector ❺.
- Disconnect plug-in connectors ❻.



- Remove screw ❷.
- Remove the cable binders.
- Take off the frame protector.



- Remove screw ❸.
- Remove the cable binders.
- Take off the frame protector.



Info

Pay attention to the holding lugs.



- Loosen hose clip **9**.

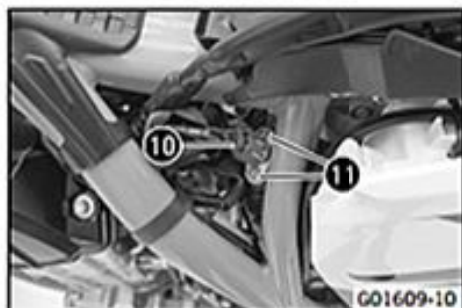

- Pull back the protection cap.
- Detach connector **10**.
- Remove screws **11**.
- Remove the intake air temperature sensor.

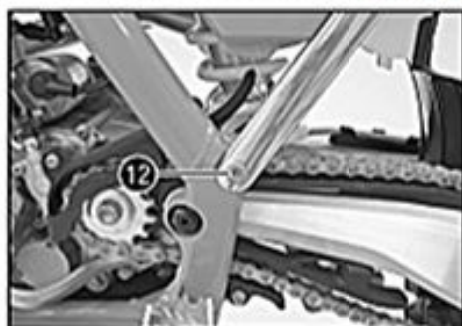

- Remove screw **12**.
- Loosen screw **13**.
- Repeat the operation on the opposite side.
- Lift the subframe.

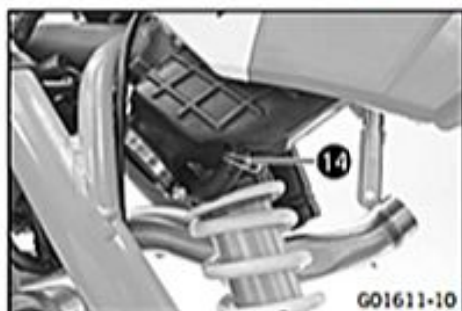

- Push back hose clamp **14**.
- Detach the vent hose.
- Swing up the subframe and secure it.



- Remove screw **15**.
- Swing back the shock absorber and twist it slightly.



- Remove springs **16**.

Spring hooks (50305017000) (☛ p. 263)



- Remove screw **17**.
- Take off the manifold.



- Loosen hose clips **18**.
- Detach the radiator hoses.

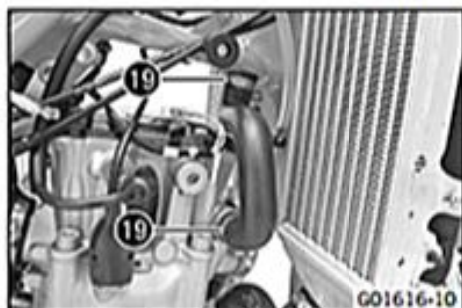

- Loosen hose clips **19**.
- Remove the radiator hose.



- Pull back the protection cap.
- Remove nut **20**.



- Remove screw **21**.

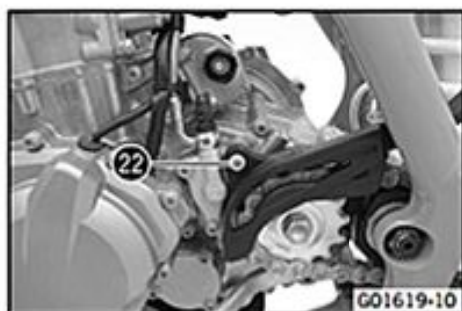

- Remove screw 22.
- Take off the engine sprocket cover.



- Remove screws 23.
- Remove the cable binders.
- Take off the clutch slave cylinder and hang it to the side.

**Info**

Do not kink the clutch line.
Do not activate the clutch lever if the clutch slave cylinder has been removed.



- Remove the chain connecting link.
- Take off the chain.



- Remove screw 24.
- Take off the shift lever.

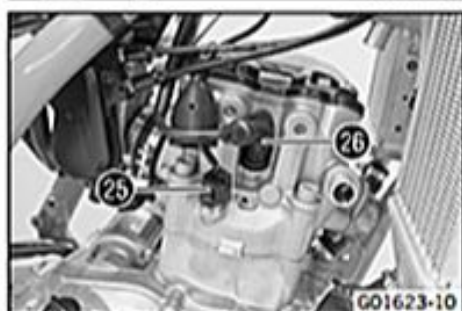

- Pull back the protection cap.
- Detach connector 25.
- Pull off spark plug connector 26.



- Loosen hose clip 27.
- Pull the throttle valve body toward the rear out of the intake flange and hang it to one side.

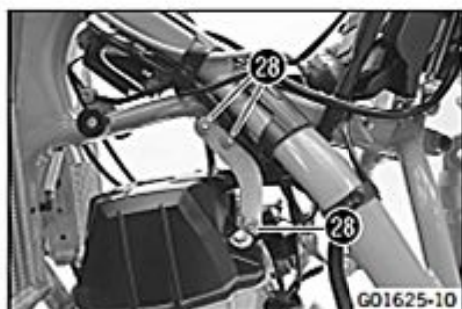

- Remove screw caps 28.
- Remove the engine braces.



- Remove spring 29.



- Remove nut 30.
- Remove the swingarm pivot.
- Pull the swingarm slightly toward the rear.



- Remove screws 31.

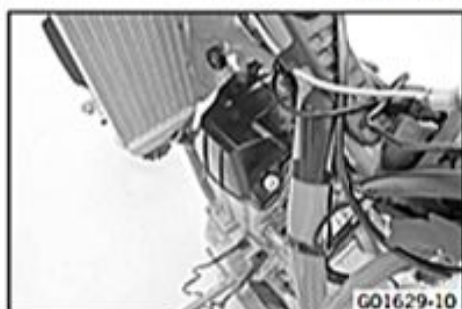

- Lift out the engine from the side.

**Info**

You should have an assistant for this step.
Make sure that the motorcycle is sufficiently secured against falling over.
Protect the frame and attachments from damage.

16.2 Installing the engine

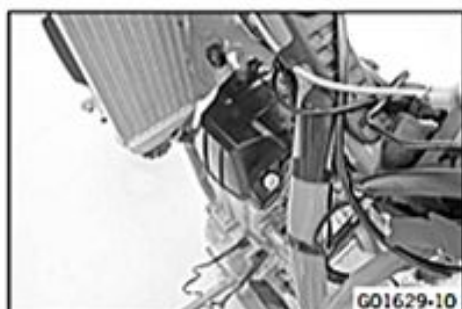
**Main work**

- Position the engine in the frame.

**Info**

You should have an assistant for this step.
Make sure that the motorcycle is sufficiently secured against falling over.
Protect the frame and attachments from damage.



- Mount screws **1** but do not tighten yet.

Guideline

Engine carrying screw	M10	60 Nm (44.3 lbf ft)
-----------------------	-----	------------------------

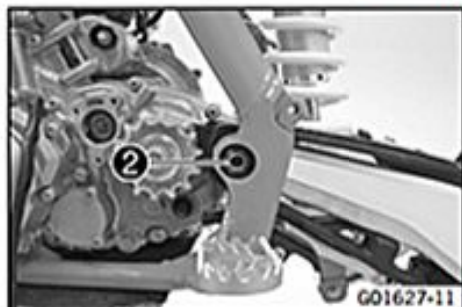

- Position the swingarm.
- Insert the swingarm pivot.
- Mount and tighten nut **2**.

Guideline

Nut, swingarm pivot	M16x1.5	100 Nm (73.8 lbf ft)
---------------------	---------	-------------------------

- Tighten screws **1**.

Guideline

Engine carrying screw	M10	60 Nm (44.3 lbf ft)
-----------------------	-----	------------------------



- Mount spring **3**.

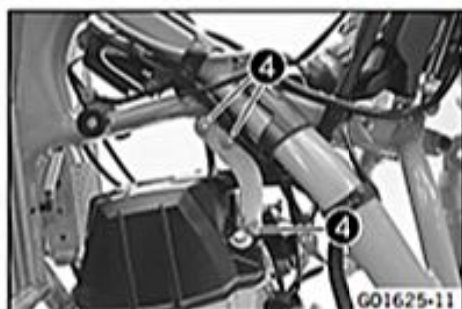

- Position the engine braces.
- Mount and tighten screws **4**.

Guideline

Screw, engine brace	M8	33 Nm (24.3 lbf ft)
---------------------	----	------------------------



- Position the throttle valve body.
- Tighten hose clip **5**.



- Plug in connector **6**.
- Position the protection cap.
- Mount the spark plug connector **7**.



- Position the shift lever.
- Mount and tighten screw 8 with the washers.

Guideline

Screw, shift lever	M6	14 Nm (10.3 lbf ft)	Loctite® 243™
--------------------	----	------------------------	---------------

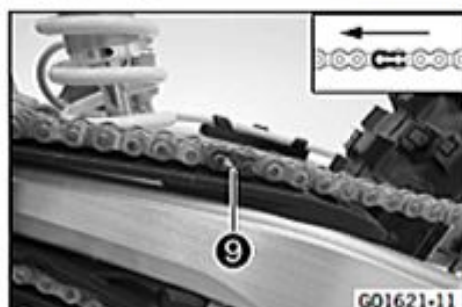

- Mount the chain.
- Connect the chain with connecting link 9.



- Position the clutch slave cylinder with the gasket.
- Mount and tighten screws 10.

Guideline

Screw, clutch slave cylinder	M6	10 Nm (7.4 lbf ft)	
------------------------------	----	--------------------	--

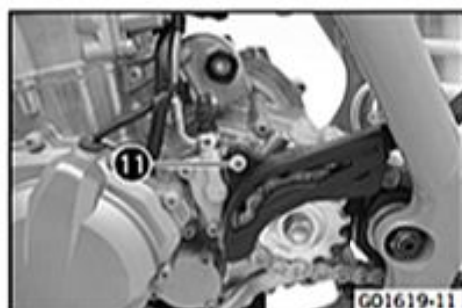

- Position the engine sprocket cover.
- Mount and tighten screw 11.

Guideline

Screw, clutch slave cylinder	M6	10 Nm (7.4 lbf ft)	
------------------------------	----	--------------------	--



- Mount and tighten screw 12.

Guideline

Remaining screws, chassis	M8	25 Nm (18.4 lbf ft)	
---------------------------	----	------------------------	--



- Position the positive cable on the starter motor.
- Mount and tighten nut 13.

Guideline

Remaining nuts, chassis	M6	10 Nm (7.4 lbf ft)	
-------------------------	----	--------------------	--

- Mount the protection cap.



- Mount the radiator hose.
- Position hose clips **14** and tighten.



- Mount the radiator hoses.
- Position hose clips **15** and tighten.

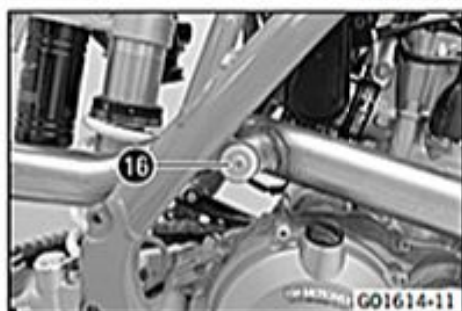

- Slip in the manifold.
- Mount screw **16** but do not tighten yet.

Guideline

Remaining screws, chassis	M8	25 Nm (18.4 lbf ft)
---------------------------	----	------------------------



- Mount springs **17**.

Spring hooks (50305017000) (☛ p. 263)

- Tighten screw **16**.

Guideline

Remaining screws, chassis	M8	25 Nm (18.4 lbf ft)
---------------------------	----	------------------------



- Position the shock absorber.
- Mount and tighten screw **18**.

Guideline

Screw, top shock absorber	M10	60 Nm (44.3 lbf ft)	Loctite® 2701™
---------------------------	-----	------------------------	----------------

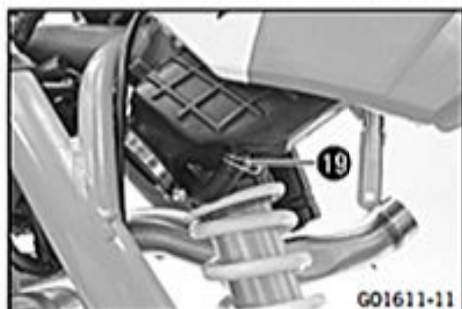

- Remove the fixation and lower the subframe.
- Mount the vent hose and position hose clamp **19**.



- Position the subframe.

**Info**

Watch out for the intake flange.

- Mount and tighten screw 20.

Guideline

Screw, subframe	M8	35 Nm (25.8 lbf ft)	Loctite® 2701™
-----------------	----	------------------------	----------------

- Remove screw 21.
- Mount and tighten screw 21.

Guideline

Screw, subframe	M8	35 Nm (25.8 lbf ft)	Loctite® 2701™
-----------------	----	------------------------	----------------

- Repeat the operation on the opposite side.



- Position the intake air temperature sensor.
- Mount and tighten screws 22.

Guideline

Screw, intake air temperature sensor	M5	2 Nm (1.5 lbf ft)	
--------------------------------------	----	-------------------	--

- Plug in connector 23.
- Mount the protection cap.



- Position and tighten hose clip 24.



- Position the frame protector.

**Info**

Pay attention to the holding lugs.

- Mount and tighten screw 25.

Guideline

Screw, frame protector	M5	3 Nm (2.2 lbf ft)	
------------------------	----	-------------------	--

- Mount the cable binder.



- Position the frame protector.
- Mount and tighten screw 26.

Guideline

Screw, frame protector	M5	3 Nm (2.2 lbf ft)	
------------------------	----	-------------------	--

- Mount the cable binder.

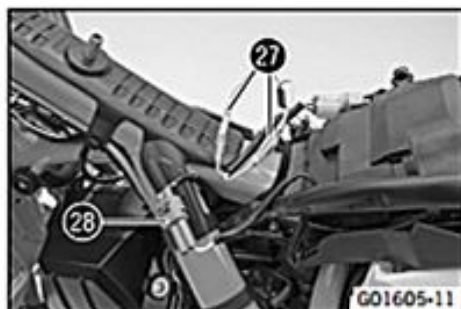

- Connect plug-in connectors 27.
- Connect plug-in connector 28.
- Route the cable so it is tension-free and secure it with cable binder.

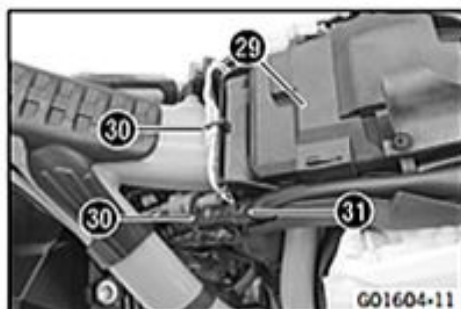

- Mount EFI control unit 29.
- Mount cable binder 30. Connect cable holder 31.



- Connect negative cable 32 of the battery.



- Remove filler plug 33 and fill in the engine oil.

Engine oil	1.50 l (1.59 qt.)	Engine oil (SAE 10W/50) (☛ p. 258)
------------	-------------------	------------------------------------

- Mount and tighten filler plug 33.

Finishing work

- Install the main silencer. (☛ p. 101)
- Install the fuel tank. (☛ p. 108)
- Mount the seat. (☛ p. 107)
- Remove the motorcycle from the lift stand. (☛ p. 10)
- Refill the coolant. (☛ p. 224)
- Execute the initialization run. (☛ p. 233)
- Take a short test ride.
- Read out the fault memory using the KTM diagnostics tool.
- Check the engine for leakage.
- Check the engine oil level. (☛ p. 225)
- Check the coolant level. (☛ p. 222)

16.3 Engine disassembly

16.3.1 Preparations



- Mount the special tool on the engine assembly stand.

Engine bracket (78029002000) (☞ p. 268)

Engine assembly stand (61229001000) (☞ p. 266)

- Mount the engine on the special tool.

**Info**

Have an assistant help you or use a motorized hoist.

16.3.2 Draining the engine oil

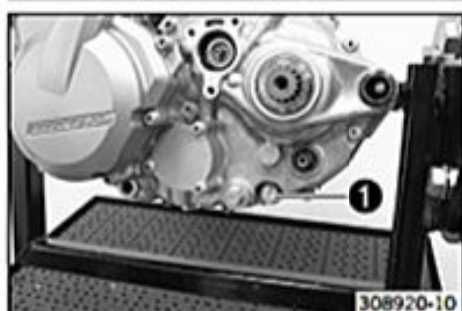

- Remove oil drain plug ① with the magnet and seal ring.

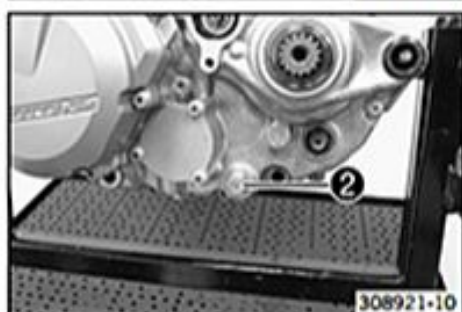

- Remove screw plug ②.
- Completely drain the engine oil.

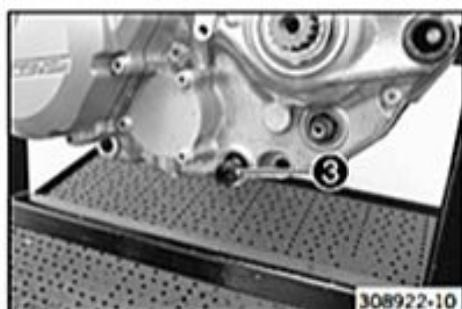

- Remove the long oil screen ③.



- Remove screw plug ④ with the short oil screen.

16.3.3 Removing the clutch push rod

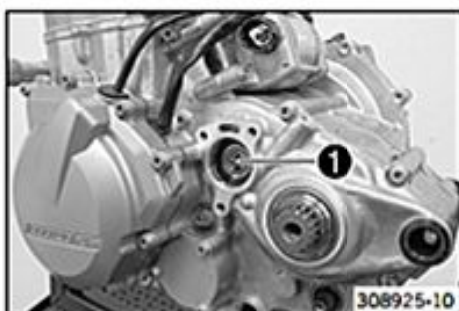

- Remove clutch push rod ①.

16.3.4 Removing the oil filter

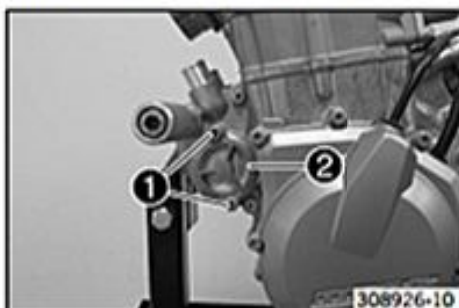

- Remove screws ①.
- Remove the oil filter cover ② with the O-ring.

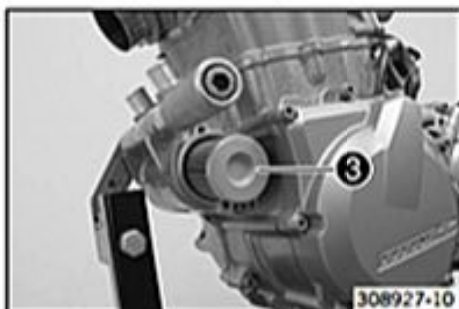

- Pull oil filter ③ out of the oil filter housing.

Circlip pliers reverse (51012011000) (☛ p. 263)

16.3.5 Removing the starter motor



- Remove screws ① and take off the starter motor.

16.3.6 Removing the spark plug



- Remove the spark plug using the special tool.

Spark plug wrench (75029172000) (☛ p. 268)

16.3.7 Removing the valve cover



- Remove screws ①.
- Take off the valve cover with the valve cover seal.

16.3.8 Removing the alternator cover

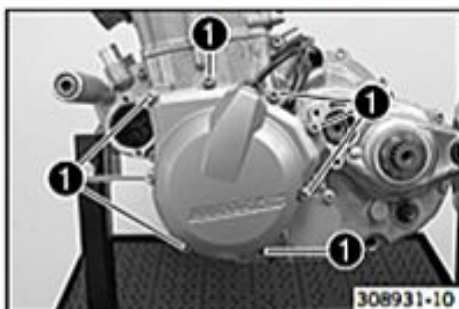

- Remove screws ①.
- Take off the alternator cover.

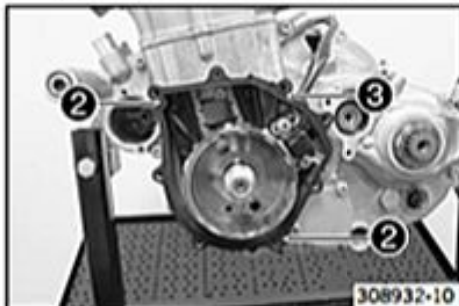

- Remove locating pins ②.
- Take off the alternator cover gasket ③.

16.3.9 Positioning the engine at ignition top dead center

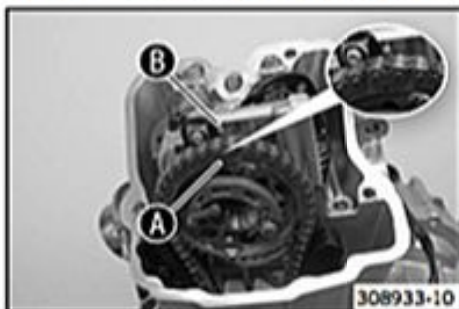

- Align camshaft marking ① with marking ② on the cylinder head.

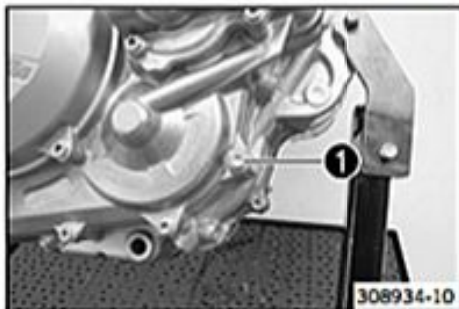

- Remove screw ①.



- Screw in special tool ②.

Locking screw (113080802) (☞ p. 262)

16.3.10 Removing the timing chain tensioner

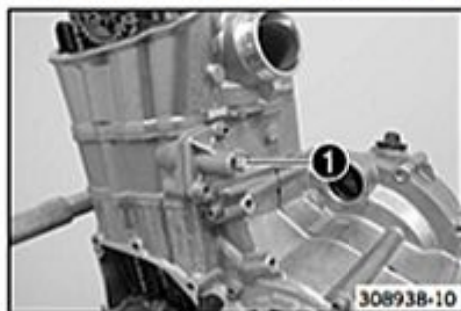

- Remove screw ① with the washer and spring.



- Remove screws ②.
- Take off the chain adjuster with the gasket.

16.3.11 Removing the camshaft

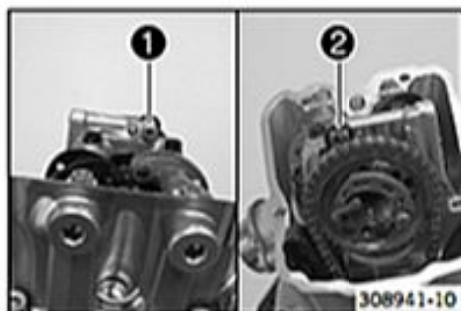

- Remove screw ①. Remove the camshaft support plate ②.



- Pull the camshaft out of the bearing seats. Take the timing chain off the camshaft gear. Remove the camshaft.

16.3.12 Removing the cylinder head

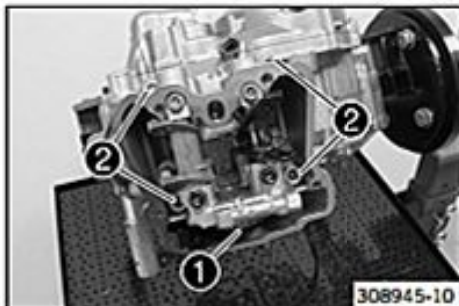

- Remove screw ①.
- Unscrew screws ② in a crisscross pattern and remove.
- Remove the cylinder head.



- Take off dowels ③.
- Remove cylinder head gasket ④.

16.3.13 Removing the piston



- Push the cylinder upward.

**Info**

Only push the cylinder as far up as necessary to take the piston pin out.

- Remove the piston pin retainer ①.
- Remove the piston pin.
- Take off the cylinder and piston.
- Push the piston upward out of the cylinder.

**Info**

If no further work is to be performed on the cylinder and piston, the piston can remain in the cylinder.

- Take off dowels ② and cylinder base gasket ③.



16.3.14 Removing the rotor



- Remove nut ① with the spring washer.



- Mount special tool ② on the rotor.

Extractor (58012009000) (☛ p. 264)

- Hold the special tool and pull off the rotor by turning in the screw.
- Remove the spring washer.

16.3.15 Removing the timing chain

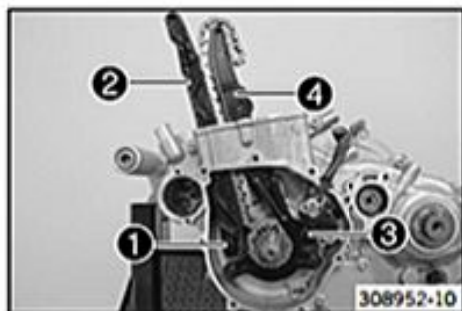

- Remove screw ①.
- Take off timing chain guide rail ② toward the top.
- Remove screw ③.
- Remove timing chain tensioning rail ④ toward the top.

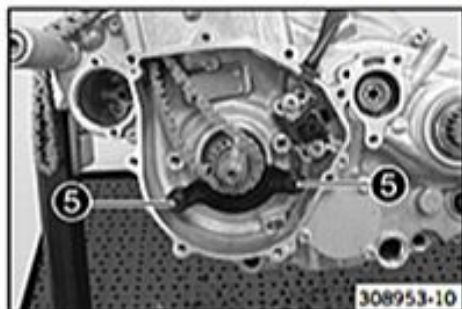

- Remove screws ⑤.
- Remove the timing chain securing guide.

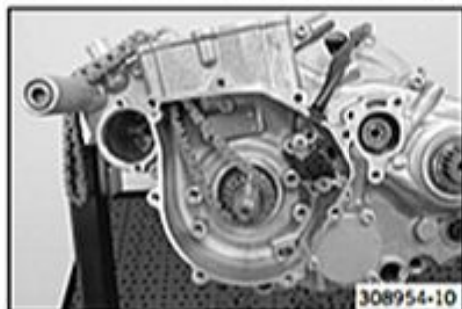

- Take off the timing chain.

i Info

If the timing chain is going to be used again, mark the direction of travel.

16.3.16 Removing the ignition pulse generator



- Remove screws ①.
- Pull the cable sleeve out of the engine case.
- Take off the crankshaft position sensor.

16.3.17 Removing the suction pump

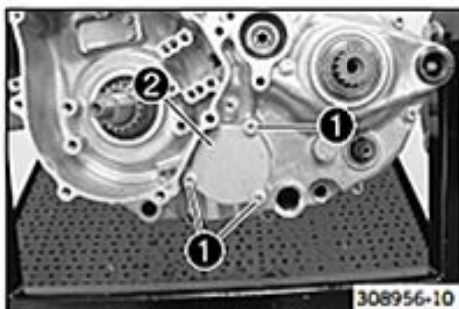

- Remove screws 1.
- Take off oil pump cover 2 of the suction pump.

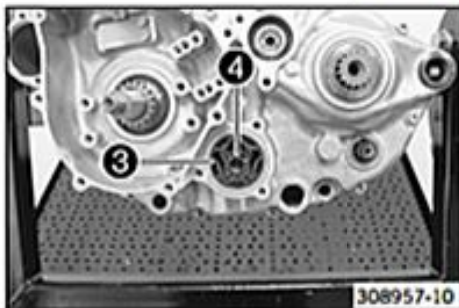

- Remove external rotor 3 and internal rotor 4.

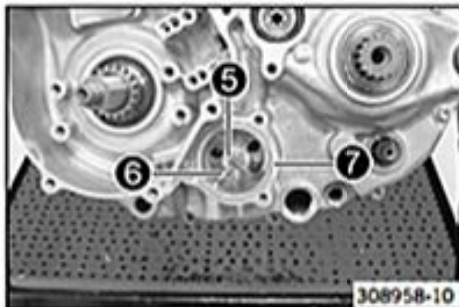

- Take off pin 5.
- Remove pin 6 upward.
- Remove O-ring 7.

16.3.18 Removing the water pump cover

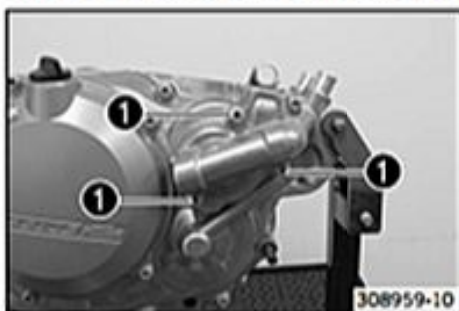

- Remove screws 1. Take off the water pump cover.
- Take off the water pump cover seal.

16.3.19 Removing the clutch cover

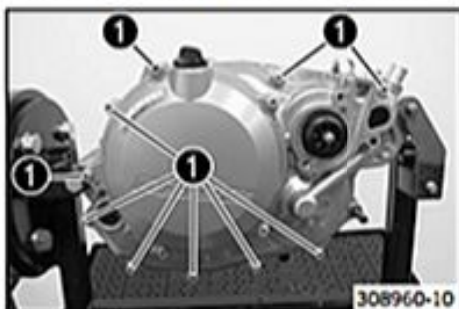

- Remove screws 1.
- Take off the clutch cover.

**Info**

If work is to be performed on the water pump, unscrew the nut of the water pump impeller.

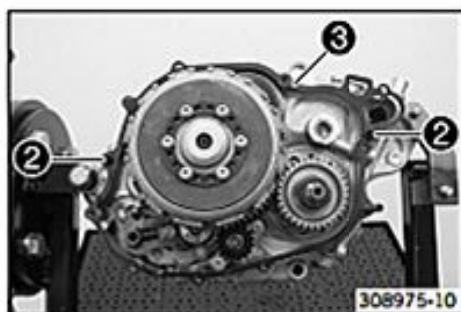

- Remove dowels ②.
- Take off clutch cover gasket ③.

16.3.20 Removing the clutch discs

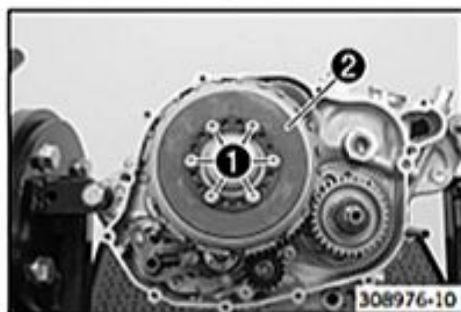

- Remove screws ①.
- Take off spring retainer ②.

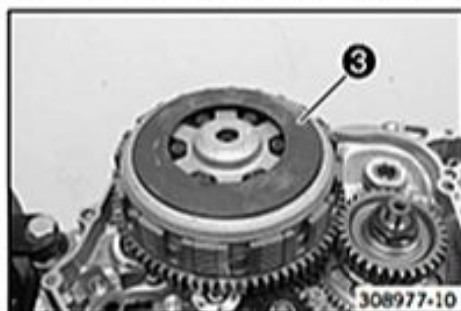

- Take off spring washer ③.

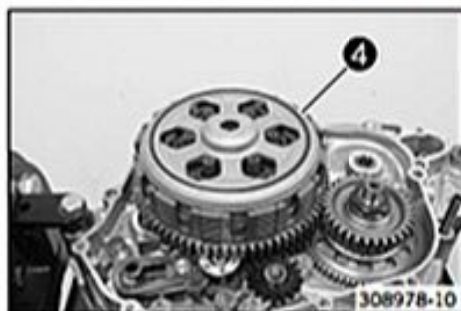

- Take off pretension ring ④.

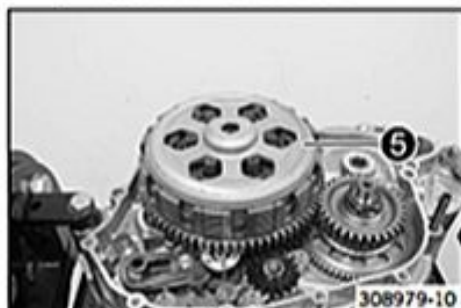

- Take off pressure cap ⑤.

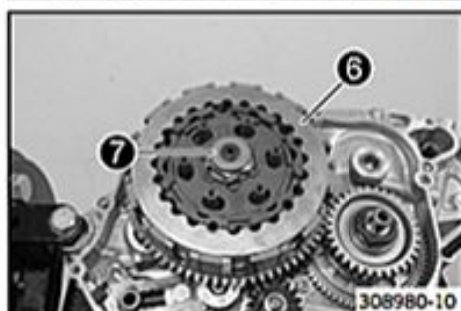

- Completely remove clutch disc pack ⑥.
- Remove clutch pressure piece ⑦.

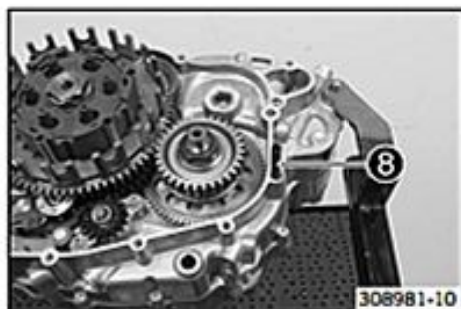

- Remove special tool ⑧.

Locking screw (113080802) (☞ p. 262)

16.3.21 Removing the outer clutch hub



- Lock the outer clutch hub and primary gear using special tool ①.

Gear quadrant (80029004000) (☞ p. 270)

- Remove nut ②.



Info

Left-handed thread.

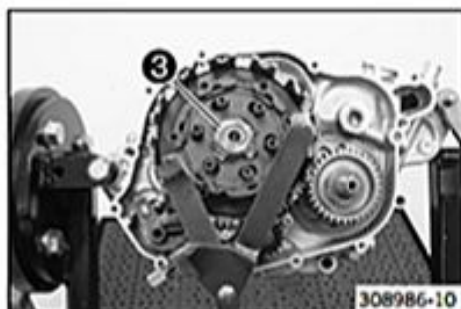

- Bend up the lock washer.
- Hold the inner clutch hub with the special tool.

Clutch holder (51129003000) (☞ p. 264)

- Remove nut ③ with the lock washer.

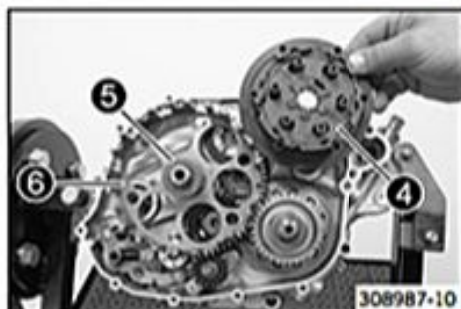

- Take off inner clutch hub ④ and washer ⑤.



Info

The washer usually sticks to the inner clutch hub.

- Take off ⑥.



- Take off both needle bearings ⑦ and collar bushing ⑧.

16.3.22 Removing the torque limiter



- Remove screw ① with the washer.
- Take off the torque limiter.

16.3.23 Removing the starter idler gear

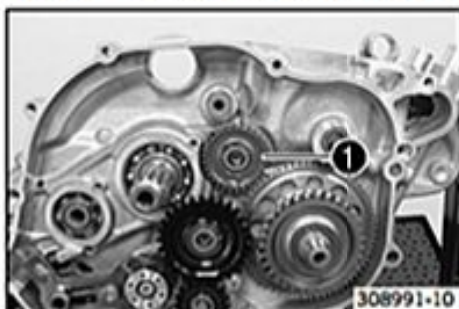

- Remove the lock ring and washer.
- Take off starter idler gear ①.

16.3.24 Removing the shift shaft

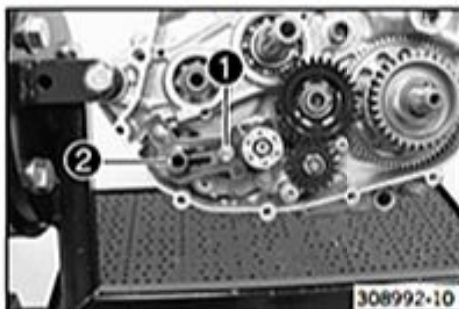

- Push sliding plate ① away from the shift drum locating unit.
- Remove shift shaft ② with the washer.

16.3.25 Removing the shift drum locating unit

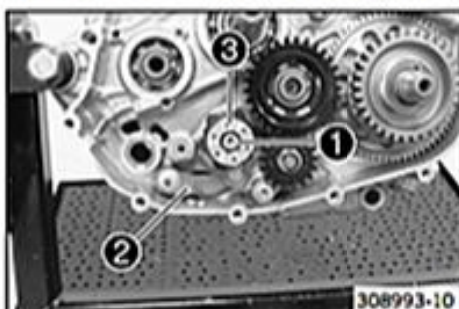

- Remove screw ①.
- Push away locking lever ② from shift drum locating unit ③ and remove the shift drum locating unit.
- Relieve tension from the locking lever.

16.3.26 Removing the locking lever

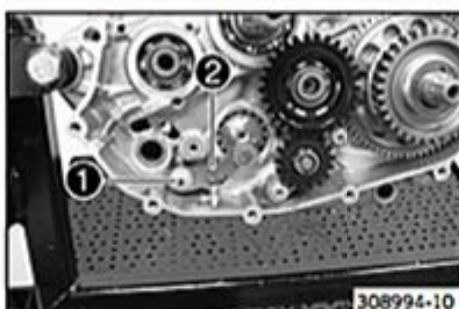

- Unscrew ① and remove together with locking lever ②, washer, sleeve and spring.

16.3.27 Removing the force pump



- Remove lock ring ①.
- Take off washer ②.
- Remove oil pump idler gear ③.

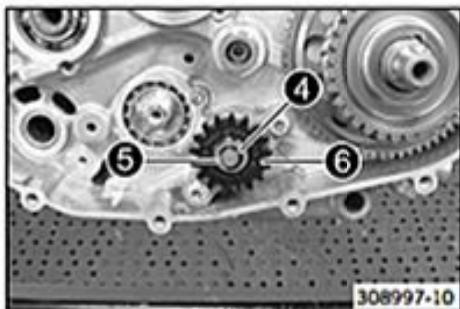

- Remove lock washer ④.
- Take off washer ⑤.
- Take off oil pump gear wheel ⑥.



- Remove pin ⑦.

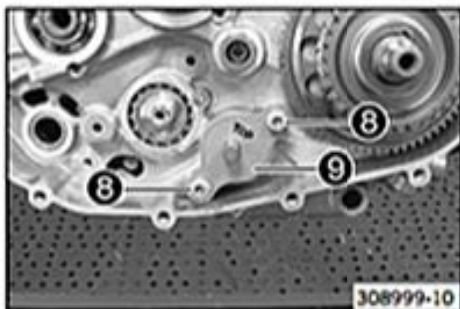

- Remove screws ⑧.
- Take off oil pump cover ⑨.

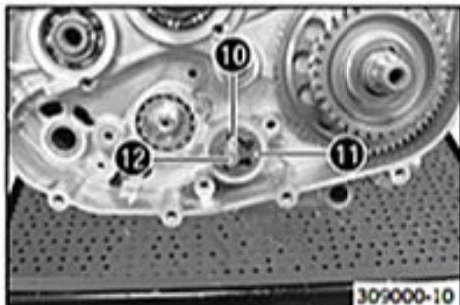

- Remove internal rotor ⑩ and external rotor ⑪.
- Remove the pin.
- Push oil pump shaft ⑫ inward and take it out of the engine from the ignition side.

16.3.28 Removing the primary gear

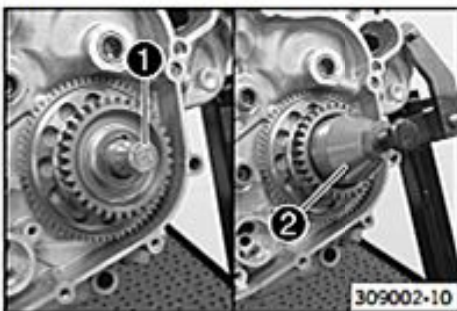

- Insert special tool **1** in the crankshaft.

Protection cover (75029090000) (☞ p. 267)

- Install special tool **2**.

Extractor (75029021000) (☞ p. 266)

- Hold it using the special tool and pull off the primary gear by turning the screw in.
- Remove the special tools.

16.3.29 Removing the freewheel gear



- Remove the spring washer **1**.
- Take off free-wheel gear **2**.

16.3.30 Removing the left engine case section

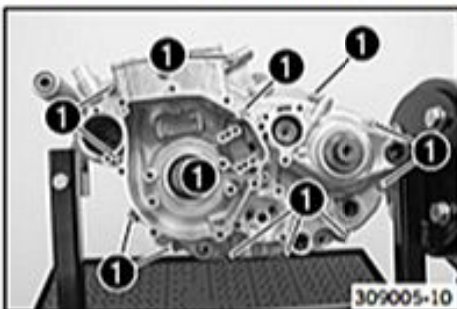

- Remove screws **1**.

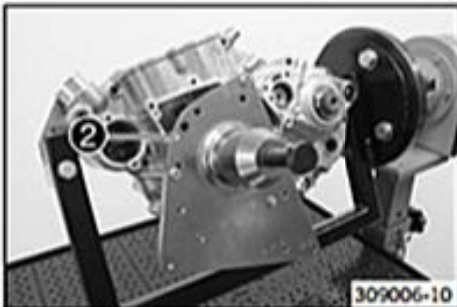

- Mount special tool **2** with the appropriate screws.

Case separating tool (90129048000) (☞ p. 270)

i Info
Use the drill hole marked with 781.

- Tilt the left section of the engine case upward and remove the screw connections of the engine fixing arm.
- Take off the section of the engine case.

i Info
Do not subject the section of the engine case to any stress.

- Remove the special tool.
- Take off the left section of the engine case.
- Remove spacer **3**.



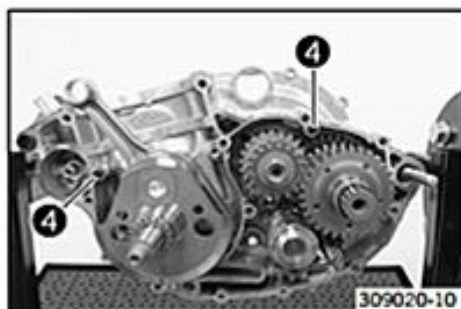

(SX-F EU)

- Remove dowels 4.

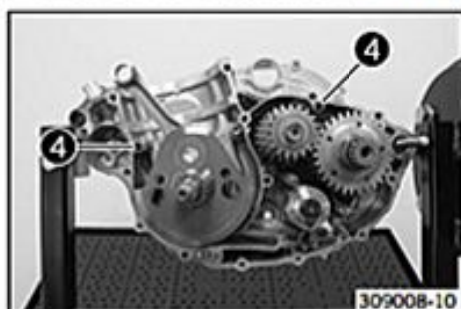

(SX-F USA, XC-F)

- Remove dowels 4.

16.3.31 Removing the shift rails

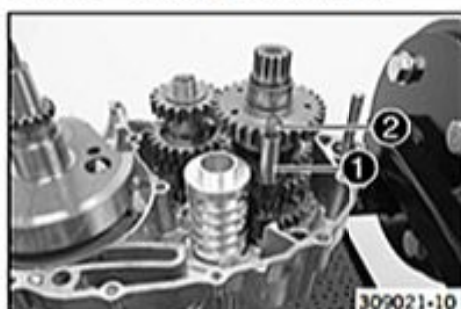

(SX-F EU)

- Remove shift rail 1 together with upper spring 2 and the lower spring.

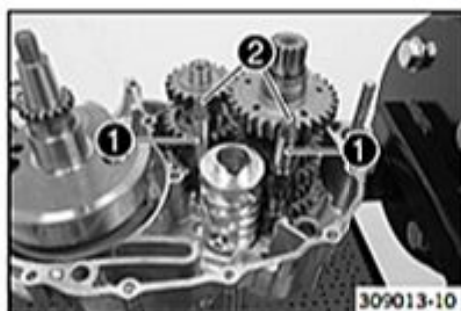

(SX-F USA, XC-F)

- Remove shift rails 1 together with upper springs 2 and lower springs.

16.3.32 Removing the shift drum

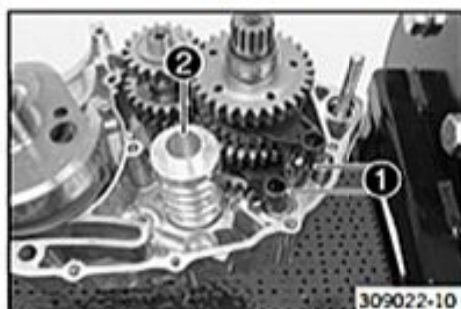

(SX-F EU)

- Swing shift forks 1 to one side.

**Info**

Do not misplace the shift rollers.

- Remove shift drum 2.

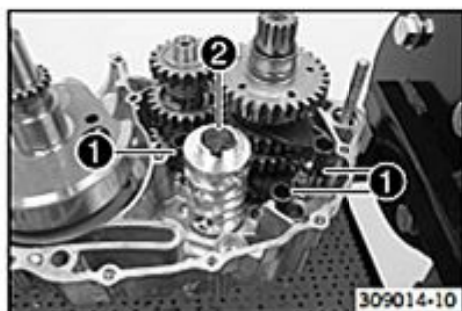

(SX-F USA, XC-F)

- Swing shift forks **1** to one side.

**Info**

Do not misplace the shift rollers.

- Remove shift drum **2**.

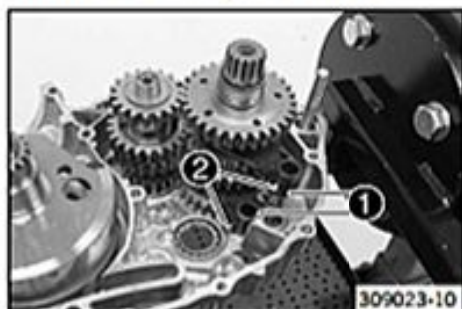
16.3.33 Removing the shift forks

(SX-F EU)

- Take shift forks **1** out of the shift grooves.

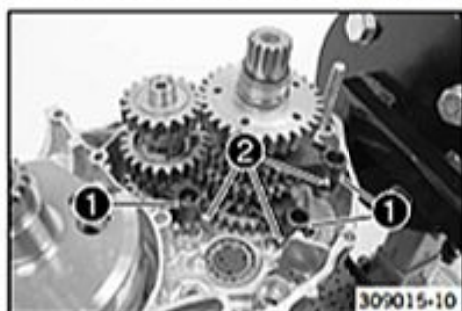
**Info**Do not misplace shift rollers **2**.

(SX-F USA, XC-F)

- Take shift forks **1** out of the shift grooves.

**Info**Do not misplace shift rollers **2**.**16.3.34 Removing the transmission shafts**

(SX-F EU)

- Remove O-ring **1**.

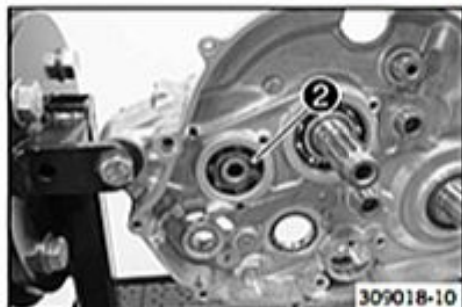

- Position the engine upright.
- Remove lock ring **2**.

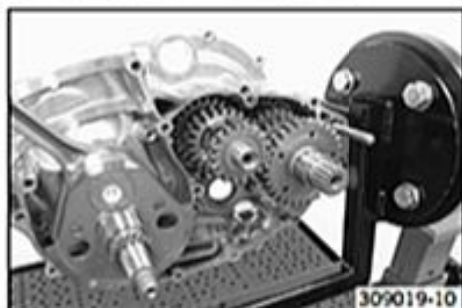
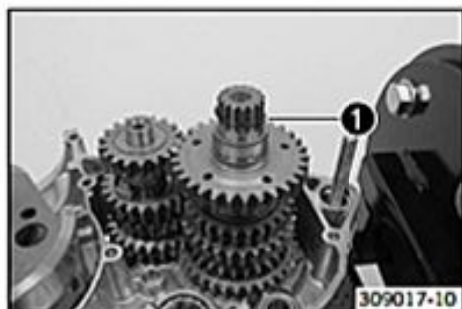
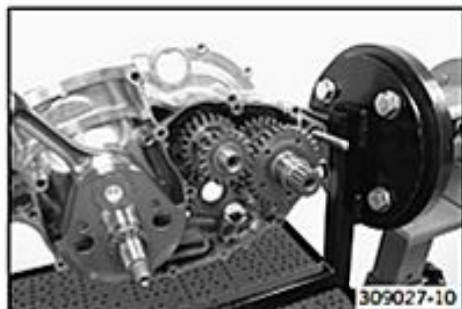

- Pull both transmission shafts out of the bearing seats together.

i Info
Make sure not to misplace the washers.

(SX-F USA, XC-F)

- Remove O-ring ①.

- Position the engine upright.
- Remove lock ring ②.

- Pull both transmission shafts out of the bearing seats together.

i Info
Make sure not to misplace the washers.

16.3.35 Removing the crankshaft



- Attach the special tool to the crankshaft.

Protection cover (75029090000) (☛ p. 267)

- Mount special tool ① onto the engine case with suitable screws.

Removal tool (78029049100) (☛ p. 269)

- Press the crankshaft out of the bearing seat.
- Take out crankshaft .
- Remove the special tools.
- Take off the right section of the engine case.

16.4 Work on individual parts

16.4.1 Work on the right section of the engine case

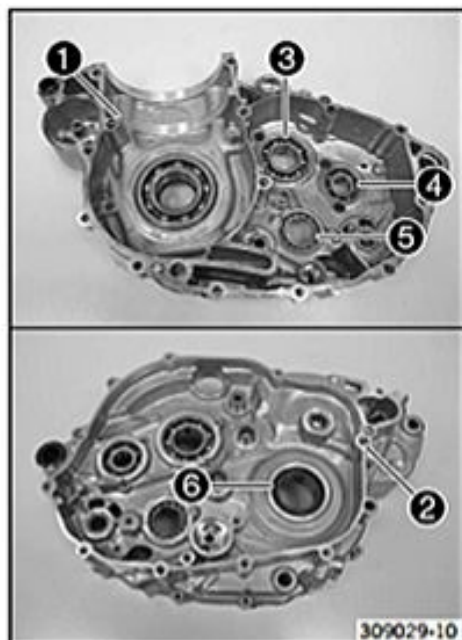
**Preparatory work**

- Remove the oil pressure regulator valve. (☛ p. 172)

Main work

- Remove all remaining dowels.
- Remove oil nozzles ① and ②.
- Remove the bearing retainer of main shaft bearing ③, of countershaft bearing ④ and of shift drum bearing ⑤.
- Remove any sealing mass remnants and clean the engine case section thoroughly.
- Warm the engine case section in an oven.

Guideline

150 °C (302 °F)

- Knock the engine case section against a level wooden plate. This will cause the bearings to drop out of the bearing seats.

**Info**

Any bearings that remain in the engine case section must be removed using a suitable tool.

- Press out shaft seal ring ⑥ of the crankshaft from the inside to the outside.

**Info**

Do not press the shaft seal ring from the outside toward the inside, as there is a small collar on the inside.

- Warm the engine case section again.

Guideline

150 °C (302 °F)

- Insert the new cold bearings into the bearing seats of the hot engine case section and, if necessary, use a suitable press drift to push the bearing from the inside to the outside, all the way to the stop or so it is flush.

**Info**

When pressing the bearing in, ensure that the engine case section is level to prevent damage.
Only press the bearings in via the outer bearing race; otherwise, the bearings will be damaged when they are pressed in.

- After the engine case section has cooled, check that the bearings are firmly seated.

**Info**

If the bearings are not firmly seated after cooling, it is likely that they will rotate in the engine case when warm. In this case, the engine case must be renewed.

- Press in the shaft seal ring from the outside toward the inside, with the open side facing outward.
- Position all bearing locks. Mount and tighten the screws.

Guideline

Screw, bearing retainer	M5	6 Nm (4.4 lbf ft)	Loctite® 2701™
-------------------------	----	----------------------	----------------

- Mount and tighten oil nozzle ①.

Guideline

Oil nozzle, piston cooling	M5	2 Nm (1.5 lbf ft)	Loctite® 243™
----------------------------	----	----------------------	---------------

- Mount and tighten oil nozzle ②.

Guideline

Oil nozzle for conrod bearing lubrication	M6x0.75	4 Nm (3 lbf ft)	
---	---------	-----------------	--

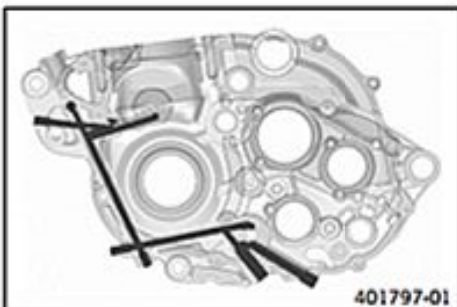

- Blow compressed air through all oil channels and check that they are clear.

Finishing work

- Install the oil pressure regulator valve. (☛ p. 173)

16.4.2 Work on the left section of the engine case

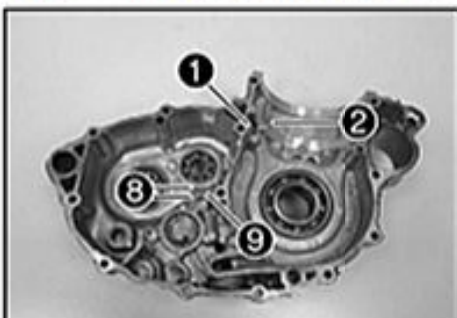

- Remove all remaining dowels.
- Remove screw 1.
- Remove oil spray tube 2.
- Remove screws 3.
- Remove membrane support plate 4 and the membrane.
- Remove shaft seal ring 5 of the countershaft and shaft seal ring 6 of the shift shaft.

Info

Shaft seal ring 7 of the crankshaft can only be removed after the crankshaft bearing is removed because of a smaller collar on the outside.

- Remove screws 8.
- Remove membrane support plate 9 and the membrane.
- Remove any sealing mass remnants and clean the engine case section thoroughly.
- Warm the engine case section in an oven.

Guideline

150 °C (302 °F)

- Knock the engine case section against a level wooden plate. This will cause the bearings to drop out of the bearing seats.

Info

Any bearings that remain in the engine case section must be removed using a suitable tool.

- Press shaft seal ring 7 of the crankshaft from the inside to the outside.
- Warm the engine case section again.

Guideline

150 °C (302 °F)

- Insert the new cold bearings into the bearing seats of the hot engine case section and, if necessary, use a suitable press drift to push the bearing all the way to the stop or so that it is flush.

Info

When pressing the bearing in, ensure that the engine case section is level to prevent damage.

Only press the bearings in via the outer bearing race; otherwise, the bearings will be damaged when they are pressed in.

- After the engine case section has cooled, check that the bearings are firmly seated.

Info

If the bearings are not firmly seated after cooling, it is likely that they will rotate in the engine case when warm. In this case, the engine case must be renewed.

- Press the shaft seal ring **7** of the crankshaft from the outside to the inside with the open side facing out.



Info

The shaft seal ring must be flush on the outside.

- Press in the shaft seal ring **5** of the countershaft and shaft seal ring **6** of the shift shaft with the open side facing inward until it is flush.
- Position membrane support plate **9** together with the membrane.
- Mount and tighten screws **8**.

Guideline

Screw, membrane	M3	1.5 Nm (1.11 lbf ft)	Loctite® 243™
-----------------	----	-------------------------	---------------

- Position membrane support plate **4** together with the membrane.
- Mount and tighten screws **3**.

Guideline

Screw, membrane	M3	1.5 Nm (1.11 lbf ft)	Loctite® 243™
-----------------	----	-------------------------	---------------

- Position oil spray tube **2**.
- Mount and tighten screw **1**.

Guideline

Screw, oil spray tube	M4	5 Nm (3.7 lbf ft)	Loctite® 243™
-----------------------	----	----------------------	---------------

- Mount the dowels.
- Blow compressed air through all oil channels and check that they are clear.

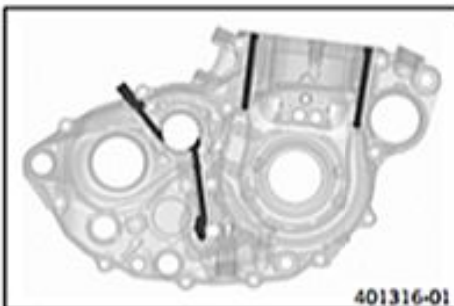

16.4.3 Removing the oil pressure regulator valve

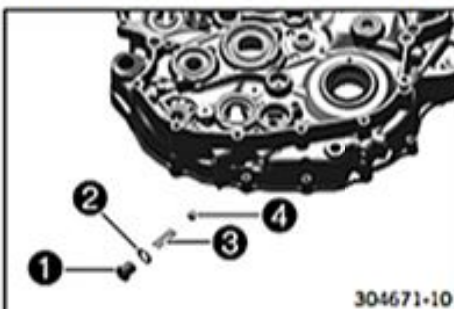

- Remove screw plug **1** with sealing washer **2**.
- Remove pressure spring **3** and ball **4**.

16.4.4 Checking spring length of oil pressure regulator valve

Preparatory work

- Remove the oil pressure regulator valve. (☛ p. 172)



Main work

- Measure the spring length of the oil pressure regulator valve.

Oil pressure regulator valve	
Minimum length of preload spring	24.5 mm (0.965 in)

- If the measured value does not meet specifications:
 - Change the spring.

Finishing work

- Install the oil pressure regulator valve. (☛ p. 173)

16.4.5 Installing the oil pressure regulator valve

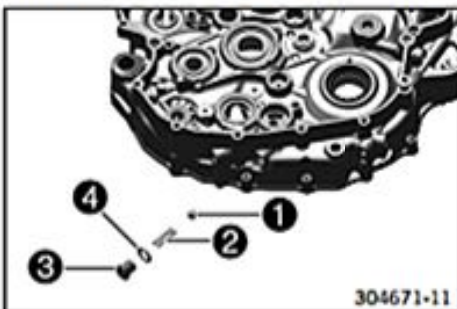

- Install ball ① and pressure spring ②.
- Mount and tighten plug ③ with sealing washer ④.

Guideline

Plug, oil pressure regulator valve	M12x1.5	20 Nm (14.8 lbf ft)
------------------------------------	---------	------------------------

16.4.6 Changing the crankshaft seal ring in the clutch cover

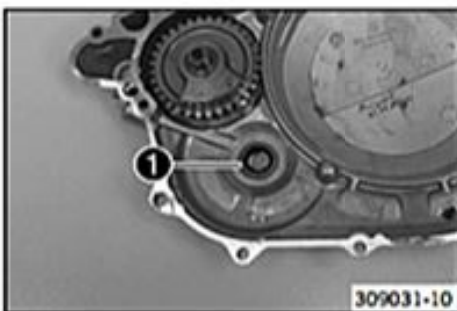

- Remove crankshaft seal ring ①.
- Press the new crankshaft seal ring into the clutch cover with the open side facing inward until it is flush.
- Grease the sealing lip.

16.4.7 Removing the water pump

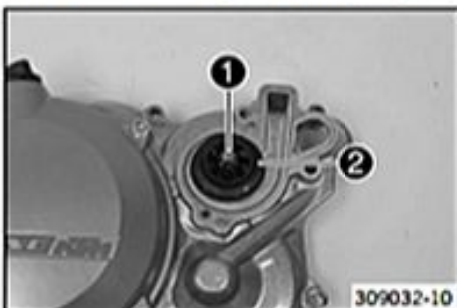

- Remove nut ①.
- Remove water pump impeller ②.

i Info
If the water pump impeller cannot be detached, then the water pump shaft can be pressed out toward the inside.

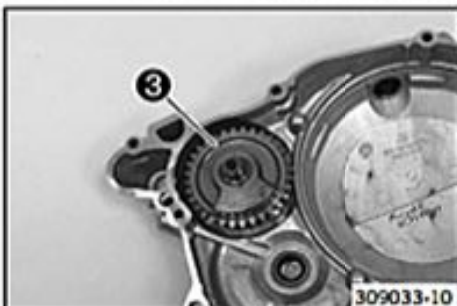

- Remove balancer shaft ③.



- Remove shaft seal ring **4**.



- Press out water pump bearing **5** toward the inside with an appropriate tool.



Info

Provide suitable support for the clutch cover while pressing out.

16.4.8 Installing the water pump

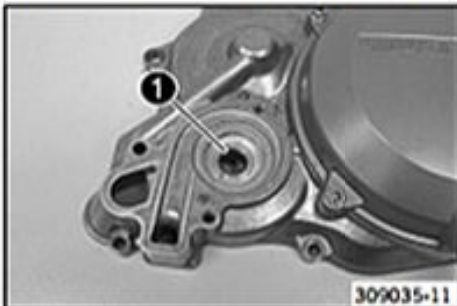

- Press water pump shaft bearing **1** in until it is flush using the appropriate tool.



Info

Support the clutch cover sufficiently when pressing in.



- Press shaft seal ring **2** all the way in.

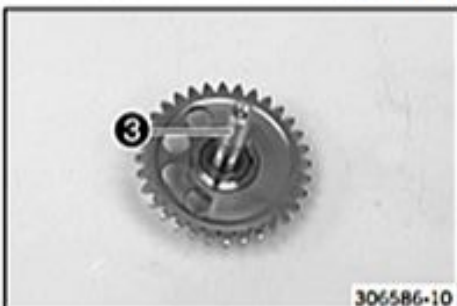

- Mount special tool **3** on the water pump shaft.

Mounting sleeve (90129005000) (☛ p. 270)

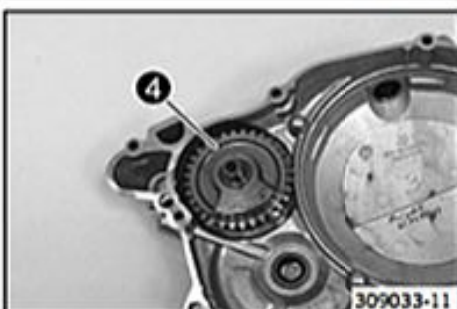

- Mount balancer shaft **4**.



Info

Be careful not to damage the shaft seal rings.

- Remove the special tool.

Mounting sleeve (90129005000) (☛ p. 270)

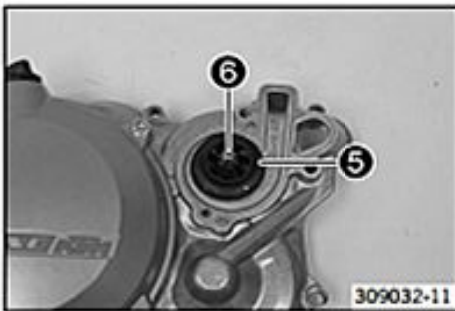

- Mount water pump impeller ⑤.
- Mount and tighten nut ⑥.

Guideline

Nut, water-pump wheel	M6	8 Nm (5.9 lbf ft)	Loctite® 243™
-----------------------	----	----------------------	---------------

16.4.9 Removing the timing chain sprocket



- Warm up the timing chain sprocket ① with a blow-dryer.
- Pull off the timing chain sprocket with the special tool.

Puller, 2-arm (60029033000) (☛ p. 265)

Info

The timing chain sprocket is usually damaged by the disassembly and must be replaced.

16.4.10 Installing the timing chain sprocket

Info

Never clamp the crankshaft with a crankshaft journal in the bench vise and try to hammer on the timing chain sprocket. In such a case, the crank webs will be distorted rendering the crankshaft unserviceable.



- Warm up the new timing chain sprocket and immediately push it onto the crankshaft.

Guideline

180 °C (356 °F)

16.4.11 Changing the connecting rod, conrod bearing, and crank pin



Main work

- Position the crankshaft with special tool ① in the press.

Separator plate (78929009000) (☛ p. 269)

- Press the crank pin out of the upper crank web with special tool ②.

Pressing device for crankshaft, complete (75029047000) (☛ p. 267)

Info

Hold the lower crank web.

- Take off the connecting rod and bearing.
- Press crank pin ③ out of the lower crank web.

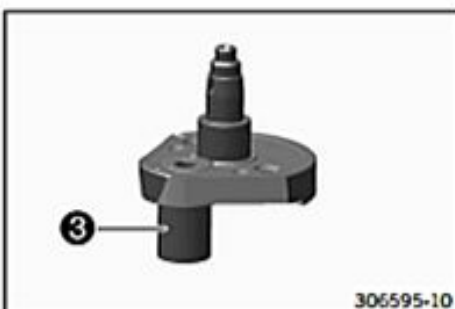

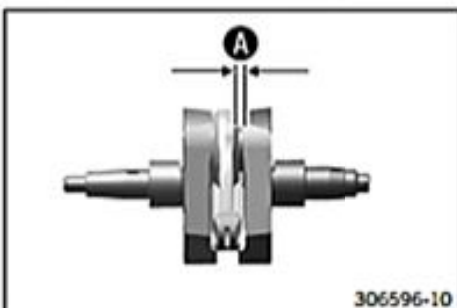
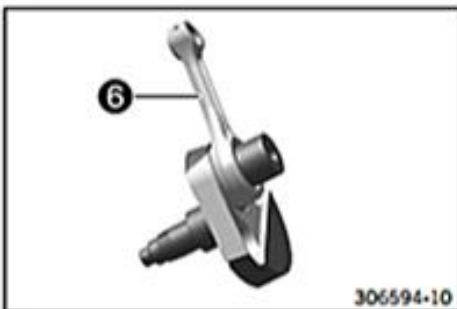
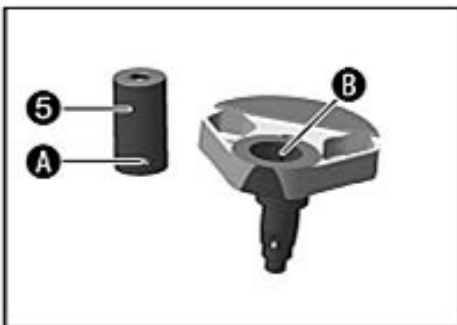

- Place the crank web onto special tool ④.

Insert for crankshaft pressing tool (78929008000) (☛ p. 269)

i Info

The special tool must be positioned with the flat surface facing downward.

- Press the new crank pin ⑤ all the way in.

✓ Oil channel ① is aligned with oil channel ②.

✗ If the oil channels are not correctly aligned, the conrod bearing will not be supplied with oil.

- Blow compressed air through the oil channels to check that they are clear.

- Mount the new connecting rod ⑥.

i Info

Lubricate the bearing thoroughly.

- Position special tools ⑦ and ⑧ on the press.

Pressing device for crankshaft, complete (75029047000) (☛ p. 267)

Insert for crankshaft pressing tool (78929008000) (☛ p. 269)

- Place the crank web in with the connecting rod and the bearing. Position the second crank web.

- Position special tool ④ with the heel at the bottom.

Insert for crankshaft pressing tool (78929008000) (☛ p. 269)

- Press the upper crank web in as far as possible.

i Info

The press mandrel must be applied above the crank pin.

- Take the crankshaft out of the special tool, and check the connecting rod for freedom of movement.

- Measure axial play ① between the connecting rod and the crank webs using the special tool.

Feeler gauge (59029041100) (☛ p. 265)

Connecting rod - end play of lower conrod bearing	0.20... 0.45 mm (0.0079... 0.0177 in)
---	---------------------------------------

- If the measured value is less than the specification:
 - Correct until it complies with the specified value.

Finishing work

- Check the crankshaft run-out at bearing pin. (☛ p. 177)

16.4.12 Checking crankshaft run-out at bearing pin

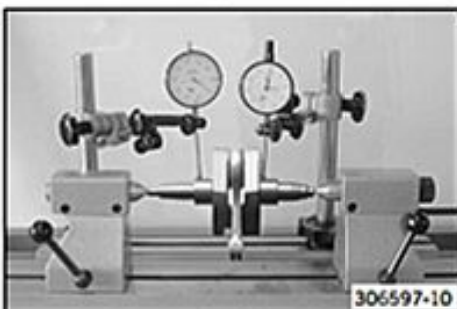

- Position the crankshaft on a roller block.
- Turn the crankshaft slowly.
- Check the crankshaft run-out on both bearing pins.

Crankshaft - run-out on bearing pin	≤ 0.04 mm (≤ 0.0016 in)
-------------------------------------	------------------------------------

- If the crankshaft run-out at the bearing pin is larger than the specification:
 - Align the crankshaft.

16.4.13 Cylinder - Nikasil® coating



Nikasil® is a surface protection layer for a coating procedure developed by Mahle. The name is derived from the two materials used in this procedure - a layer of nickel into which is embedded the particularly hard silicone carbide. The most important advantages of the **Nikasil®** coating are very good heat conductivity, resulting in much improved performance, low wear, and a lightweight cylinder.

16.4.14 Checking/measuring the cylinder

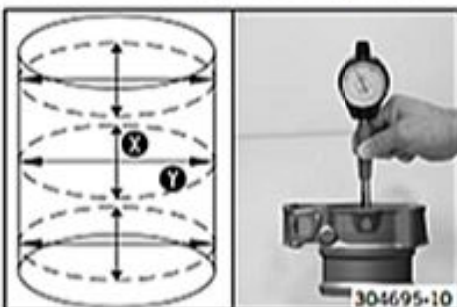

- Check the cylinder bearing surface for damage.
 - If the cylinder bearing surface is damaged:
 - Change the cylinder and piston.
- Measure the cylinder diameter at several locations on the **X**- and **Y**-axes using a micrometer to identify oval wear.

Guideline

Cylinder - drill hole diameter	
Size I	95... 95.012 mm (3.74... 3.74062 in)
Size II	95.013... 95.025 mm (3.74066... 3.74113 in)



- The cylinder size **1** is labeled on the side of the cylinder.



- Using a straightedge and the special tool, check the sealing area of the cylinder head for distortion.

Feeler gauge (59029041100) (☞ p. 265)

Cylinder/cylinder head - sealing area distortion	≤ 0.1 mm (≤ 0.004 in)
--	----------------------------------

- If the measured value does not meet specifications:
 - Change the cylinder.

16.4.15 Checking/measuring the piston

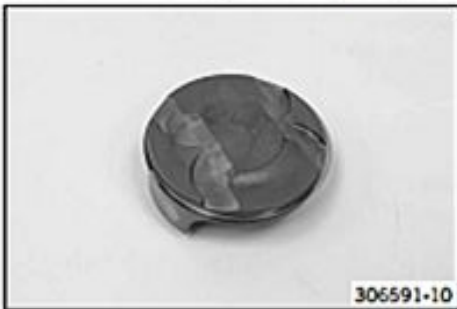

- Check the piston sliding surface for damage.
 - If the piston sliding surface is damaged:
 - Replace the piston and, if necessary, the cylinder.
- Check that the piston rings move easily in the piston ring grooves.
 - If the piston ring is stiff:
 - Clean the piston ring groove.

i Tip
An old piston ring can be used to clean the piston ring groove.

- Check the piston rings for damage.
 - If the piston ring is damaged:
 - Replace the piston ring.

i Info
Mount the piston ring with the marking facing upward.

- Check the piston pins for discoloration or signs of wear.
 - If the piston pin shows severe discoloration/signs of wear:
 - Replace the piston pin.
- Place the piston pin in the connecting rod and check the seating for play.
 - If the piston pin seating has excessive play:
 - Replace the connecting rod and piston pin.
- Measure the piston at the piston skirt, parallel to the gudgeon pin, at a distance of **A**.

Guideline

Distance A	7 mm (0.28 in)
Piston - diameter	
Size I	94.93... 94.96 mm (3.7374... 3.7386 in)
Size II	94.94... 94.97 mm (3.7378... 3.739 in)

i Info
Piston dimensions **1** are marked on the piston head.

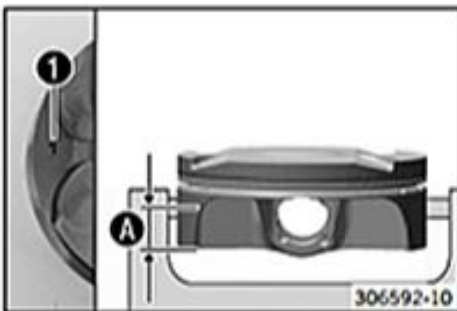

16.4.16 Checking the piston ring end gap



- Remove the piston ring from the piston.
- Place the piston ring in the cylinder and align it with the piston.

Guideline

Under the upper edge of the cylinder	10 mm (0.39 in)
--------------------------------------	-----------------

- Measure the end gap with special tool **1**.

Guideline

Piston ring end gap	
Compression ring	≤ 1 mm (≤ 0.04 in)
Oil scraper ring	≤ 1.2 mm (≤ 0.047 in)

Feeler gauge (59029041100) (☞ p. 265)

- If the end gap is more than the specified value:
 - Check/measure the cylinder. (☞ p. 177)
- If the cylinder wear is within the tolerance range:
 - Replace the piston ring.
- Mount the piston ring with the marking facing upward.

16.4.17 Measuring the piston/cylinder mounting clearance



- Check/measure the cylinder. (☞ p. 177)
- Check/measure the piston. (☞ p. 178)
- The smallest piston/cylinder mounting clearance equals the smallest cylinder bore diameter minus the largest piston diameter. The largest piston/cylinder mounting clearance equals the largest cylinder bore diameter minus the smallest piston diameter.

Guideline

Piston/cylinder - mounting clearance	
Size I	0.040... 0.082 mm (0.00157... 0.00323 in)
Size II	0.043... 0.085 mm (0.00169... 0.00335 in)
Wear limit	0.120 mm (0.00472 in)

16.4.18 Checking the oil pumps



Info

The following steps apply to both oil pumps.



- Use special tool ① to measure the play between the external rotor and the engine case.

Feeler gauge (59029041100) (☞ p. 265)

Oil pump

External rotor/engine case clearance	≤ 0.20 mm (≤ 0.0079 in)
--------------------------------------	-------------------------

- If the measured value does not meet specifications:
 - Change the oil pump and, if necessary, the engine case.
- Use special tool ① to measure the play between the external rotor and the internal rotor.

Feeler gauge (59029041100) (☞ p. 265)

Oil pump

External rotor/internal rotor clearance	≤ 0.20 mm (≤ 0.0079 in)
---	-------------------------

- If the measured value does not meet specifications:
 - Replace the oil pump.



16.4.19 Disassembling the autodecompressor



- Take lock ring ① from the autodecompression shaft and dispose of it.

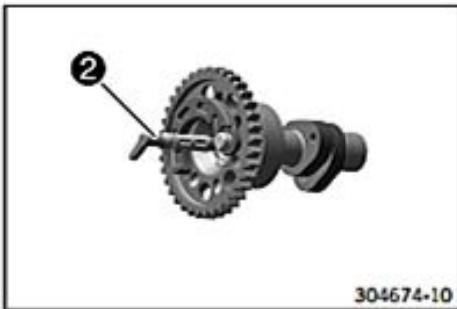

- Pull autodecompression shaft **2** out of the camshaft.

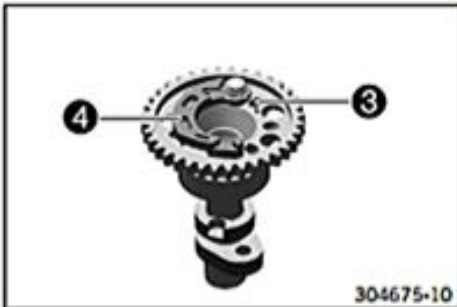

- Release and remove autodecompression spring **3**.

i Info

Autodecompression weight **4** cannot be taken off.

16.4.20 Assembling the autodecompressor

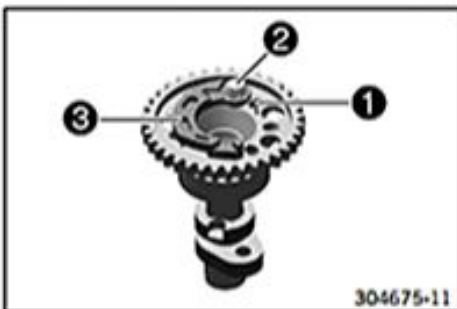

- Insert long flange **1** of the autodecompression spring in the hole, push the autodecompression spring over bearing bolt **2** and hook it into autodecompression weight **3**.

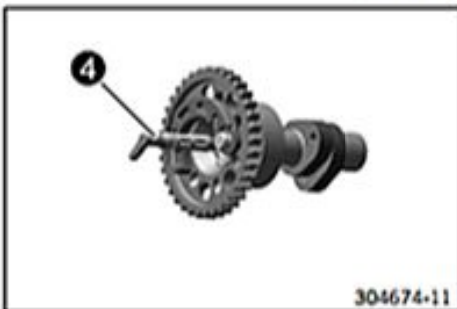

- Mount autodecompression shaft **4** in the camshaft.



- Mount new lock ring **5**.
- Perform a function check.
 - The autodecompression spring does not turn the autodecompression shaft back to the stop:
 - Pre-tension the autodecompression spring more or replace it.

16.4.21 Checking camshaft



- Check the camshaft for damage and wear.
 - If there is damage or wear:
 - Change the camshaft.
 - If the camshaft surface is damaged, check the oil supply of the camshaft and the rocker arm.
- Measure the cams of the camshaft.

Camshaft - cam height	
Exhaust	33.10... 33.30 mm (1.3031... 1.311 in)
Intake	33.90... 34.10 mm (1.3346... 1.3425 in)

- If the measured value does not meet specifications:
 - Change the camshaft.

16.4.22 Checking the timing assembly

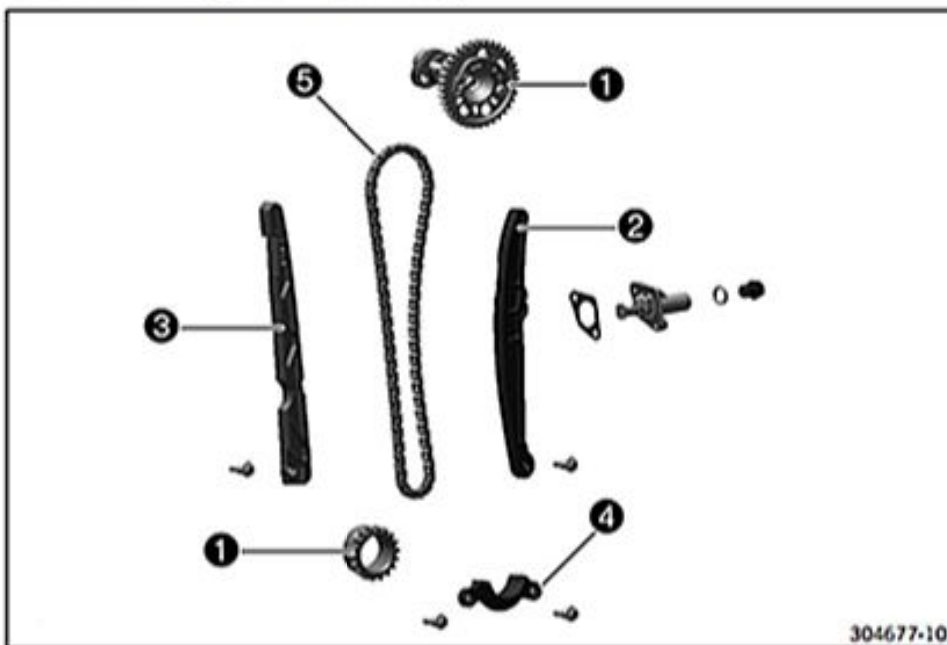

- Clean all parts well.
- Check the timing chain gear/timing chain sprocket **1** for damage and wear.
 - If there is damage or wear:
 - Change the camshaft/timing chain sprocket.
- Check the timing chain tensioning rail **2** for damage and wear.
 - If there is damage or wear:
 - Replace the timing chain tensioning rail.
- Check the timing chain guide rail **3** for damage and wear.
 - If there is damage or wear:
 - Replace the timing chain guide rail.
- Check the timing chain securing guide **4** for damage and wear.
 - If there is damage or wear:
 - Replace the timing chain securing guide.
- Check timing chain **5** for damage and wear.
 - If there is damage or wear:
 - Replace the timing chain.
- Check the timing chain links for smooth operation. Let the timing chain hang down freely.
 - The chain links no longer align in a straight line:

- Replace the timing chain.

16.4.23 Removing the rocker arm

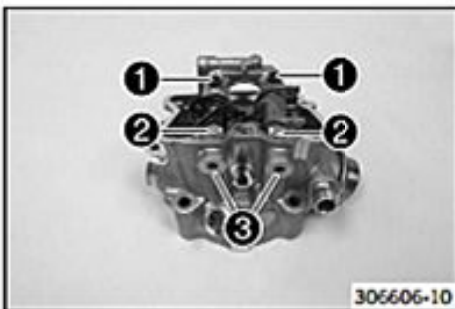

- Remove screws **1** and **2** of the rocker arm shafts.
- Remove plugs **3** with the O-rings.

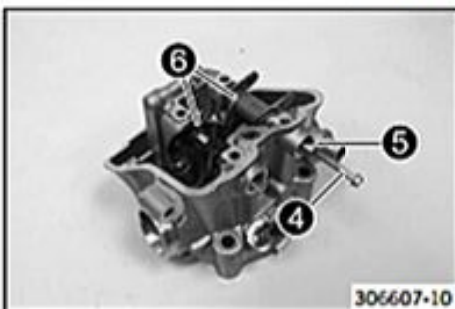

- Screw appropriate screw **4** into the rocker arm shafts. Pull out rocker arm shafts **5**.
- Take off rocker arm **6**.

16.4.24 Removing the valves



- Take the shims out of the valve spring retainers and lay them to one side according to their normal built-in position.
- Pretension the valve springs using the special tool.

Valve spring compressor (59029019000) (☛ p. 264)

Insert for valve spring lever (77029041000) (☛ p. 268)

- Remove valve keys **1** and relax the valve springs.

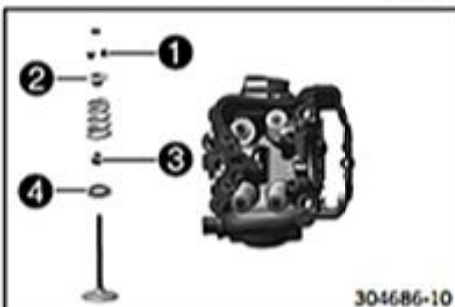

- Remove valve spring retainer **2** and the valve spring.
- Pull the valve out of the valve guide from below and remove valve stem seal **3** and valve spring seat **4**.

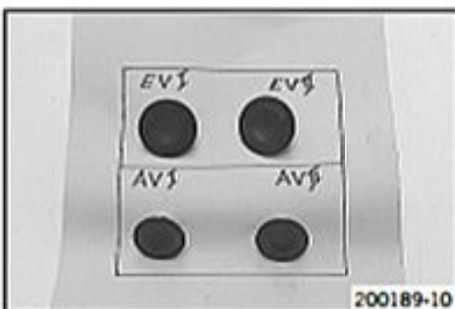

- Mark the valves according to their normal built-in position.



Info

Place the valve into a box according to the installation position and label the box.

16.4.25 Changing camshaft bearing

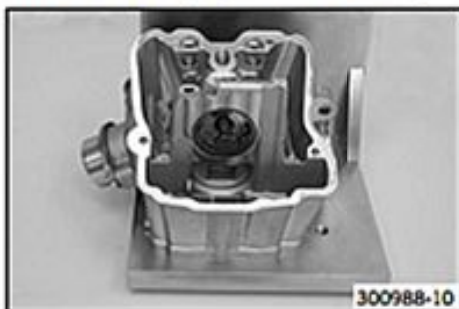

300988-10

- Mount the cylinder head.

Clamping plate (75029050000) (☞ p. 267)

- Remove the large camshaft bearing using the special tool.

Push-out drift (75029051000) (☞ p. 267)

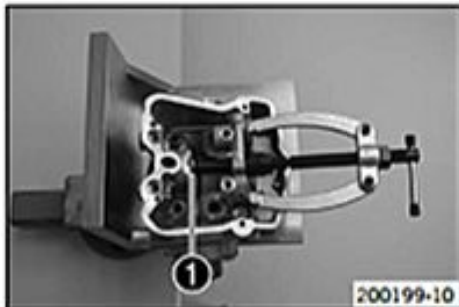

200199-10

- Remove the small camshaft bearing ① using the special tool.

Bearing puller (15112017000) (☞ p. 262)

Insert for bearing puller (15112018100) (☞ p. 263)
--



200200-10

- Press the small camshaft bearing in until flush using the special tool ②.

Push-in drift (75029044020) (☞ p. 267)
--

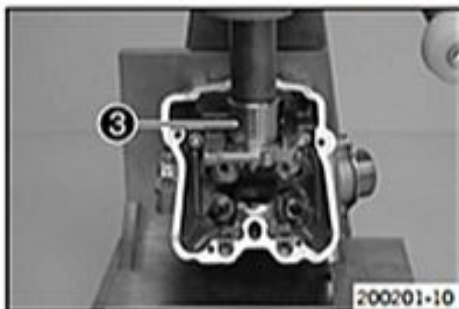

200201-10

- Press the large camshaft bearing in until flush using special tool ③.

Push-in drift (75029044010) (☞ p. 266)
--

16.4.26 Checking the valves



Info

The valve shaft is hard-chrome plated; wear generally appears at the valve guide.



200193-10

- Check the run-out at the valve plate.

Valve

Run-out at valve plate	≤ 0.05 mm (≤ 0.002 in)
------------------------	------------------------

- If the measured value does not meet specifications:
 - Change the valve.

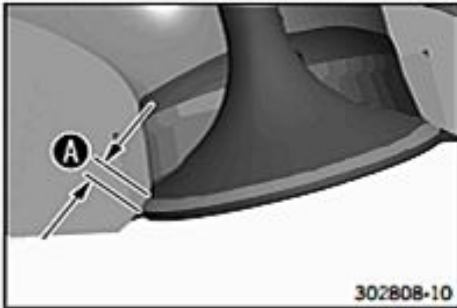

- Check sealing seat **A** on the valve.

Valve	
Intake sealing seat width	2.00 mm (0.0787 in)

Valve	
Exhaust sealing seat width	2.00 mm (0.0787 in)

- If the sealing area is not in the center of the valve seat or deviates from the specified value:
 - Rework the valve seat.

16.4.27 Checking valve springs



- Check the valve springs for breakage and wear (visual check).
 - If the valve spring is broken or worn:
 - Change the valve spring.
- Measure the length of the valve springs.

Valve spring	
Intake minimum length (without valve spring seat)	40.7 mm (1.602 in)

Valve spring	
Exhaust minimum length (without valve spring seat)	40.7 mm (1.602 in)

- If the measured value does not meet specifications:
 - Change the valve spring.

16.4.28 Checking valve spring seat



- Check the valve spring seat for breakage and wear (visual check).
 - If the valve spring seat is broken or worn:
 - Change the valve spring seat.
- Measure the thickness of the valve spring seat.

Valve spring	
Valve spring seat	1.8 mm (0.071 in)

- If the measured value does not meet specifications:
 - Change the valve spring seat.

16.4.29 Checking the cylinder head



- Check exhaust valve guides **1** using the special tool.

Limit plug gauge (59029026006) (☞ p. 265)

- If the special tool is easy to insert in the valve guide:
 - Change the valve guide and valve.

- Check intake valve guides **2** using the special tool.

Limit plug gauge (59029026006) (☞ p. 265)

- If the special tool is easy to insert in the valve guide:
 - Change the valve guide and valve.

- Check the sealing area of the spark plug thread and the valve seats from damage and cracking.
 - If there is damage or cracking:
 - Change the cylinder head.

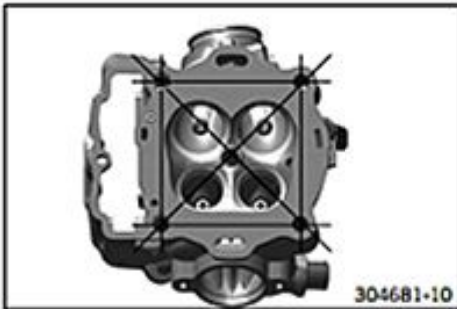

- Using a straightedge and the special tool, check the sealing area of the cylinder for distortion.

Feeler gauge (59029041100) (☞ p. 265)

Cylinder/cylinder head - sealing area distortion	≤ 0.1 mm (≤ 0.004 in)
--	-----------------------

- If the measured value does not meet specifications:
 - Change the cylinder head.

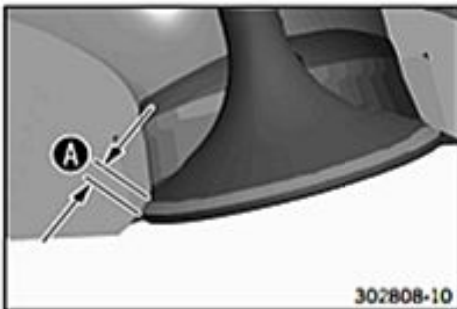

- Check sealing seat **A** of the valves.

Valve

Intake sealing seat width	2.00 mm (0.0787 in)
---------------------------	---------------------

Valve

Exhaust sealing seat width	2.00 mm (0.0787 in)
----------------------------	---------------------

- If the measured value does not meet specifications:
 - Rework the valve seat.

- Blow compressed air through all oil channels and check that they are clear.

16.4.30 Checking the rocker arm shafts



- Check the rocker arm shafts for damage and wear.
 - If there is damage or wear:
 - Change the rocker arm shafts.

16.4.31 Installing the valves

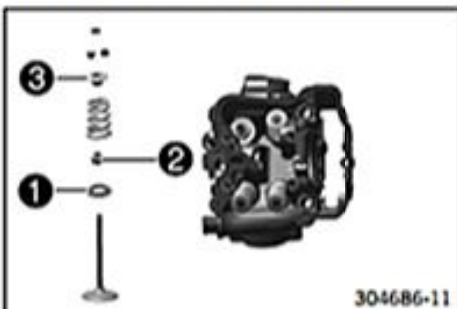

- Position valve spring seats **1**. Install new valve stem seals **2**.
- Mount the valves according to their normal built-in position.
- Mount the springs and spring retainers **3**.



- Pretension the valve springs using the special tool.

Valve spring compressor (59029019000) (☞ p. 264)

Insert for valve spring lever (77029041000) (☞ p. 268)



306618-10

- Mount the valve keys.

i Info

When mounting the valve keys, check that they are seated correctly; preferably, fix the valve keys to the valve with a little grease.

- Place shims into the valve spring retainers according to the installation position.

16.4.32 Installing the rocker arm



306608-10

- Position rocker arm ① and mount rocker arm shaft ②.
- ✓ The rocker arm shaft with marking **A** is installed on the intake side.
- ✓ Markings **A** face upward.

i Info

Make sure that the tapped hole of the rocker arm shaft is positioned facing outwards.
Align drill holes ③ of the rocker arm shafts with drill holes ④ of the cylinder head.

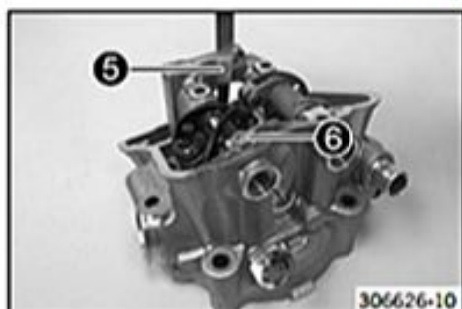

306626-10

- Use special tool ⑤ to set the distance of the intake rocker arm.

Guideline

Rocker arm - axial play	0.10 mm (0.0039 in)
Feeler gauge (59029041100) (☛ p. 265)	

- Press the rocker arm shaft of the intake side all the way into the cylinder head.
- Mount and tighten screw ⑥.

Guideline

Screw, rocker arm bearing	M7	15 Nm (11.1 lbf ft)
---------------------------	----	------------------------

- Remove special tool ⑤.

Feeler gauge (59029041100) (☛ p. 265)	
---------------------------------------	--

- Repeat these operations on the rocker arm of the exhaust side.
- Mount and tighten screws ⑦.

Guideline

Screw, rocker arm bearing	M7	15 Nm (11.1 lbf ft)
---------------------------	----	------------------------

- Mount and tighten screw plugs ⑧ with the O-ring.

Guideline

Screw plug, rocker arm	M18x1.5	30 Nm (22.1 lbf ft)
------------------------	---------	------------------------

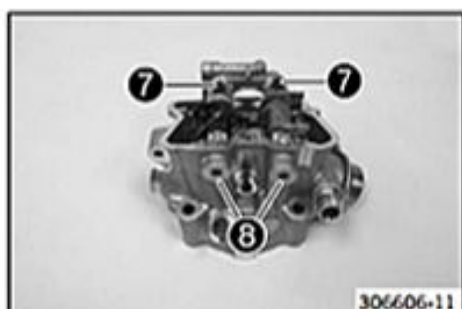

306606-11

16.4.33 Checking the clutch

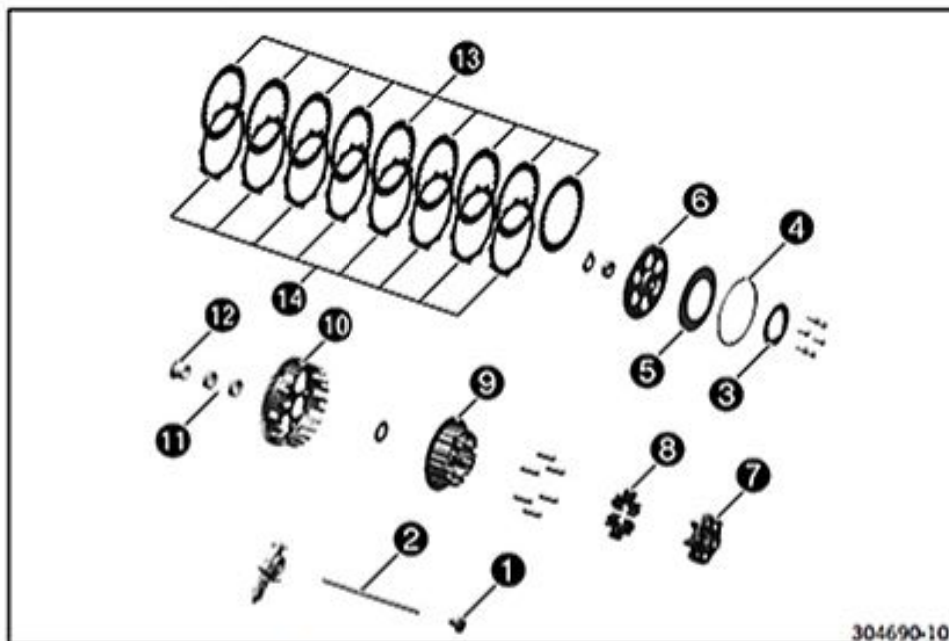

304690-10

- Check pressure piece **1** for damage and wear.
 - If there is damage or wear:
 - Change the pressure piece.
- Place push rod **2** on a level surface and check for run-out.
 - If there is run-out:
 - Change the push rod.
- Check spring retainer **3** for damage and wear.
 - If there is damage or wear:
 - Change the spring retainer.
- Check pretension ring **4** for damage and wear.
 - If there is damage or wear:
 - Change the pretension ring.
- Check spring washer **5** for damage and wear.
 - If there is damage or wear:
 - Change the spring washer.
- Check the thrust face of pressure cap **6** for damage and wear.
 - If there is damage or wear:
 - Change the pressure cap.
- Check clutch center **7** for damage and wear.
 - If there is damage or wear:
 - Change the clutch center.
- Check damping rubber **8** for damage and wear.
 - If there is damage or wear:
 - Change the damping rubbers.
- Check the inner clutch hub **9** for damage and wear.
 - If there is damage or wear:
 - Change the inner clutch hub.
- Check the contact surfaces of the clutch facing disks in outer clutch hub **10** for damage and wear.
 - If there is damage or wear:
 - Change the clutch facing discs and the clutch basket.
- Check needle bearings **11** and collar bushing **12** for damage and wear.
 - If there is damage or wear:

- Change the needle bearings and collar bushing.
- Check the intermediate clutch discs **13** for damage and wear.
 - If the intermediate clutch discs are not level and have pittings:
 - Change all intermediate clutch discs.
- Check clutch facing discs **14** for discoloration and scoring.
 - If there is discoloration or scoring:
 - Change all clutch facing discs.
- Check the thickness of clutch facing discs **14**.

Clutch facing disc - thickness	≥ 1.9 mm (≥ 0.075 in)
--------------------------------	-----------------------

- If the clutch facing disc does not meet specifications:
 - Change all clutch facing discs.

16.4.34 Checking the shift mechanism

(SX-F EU)

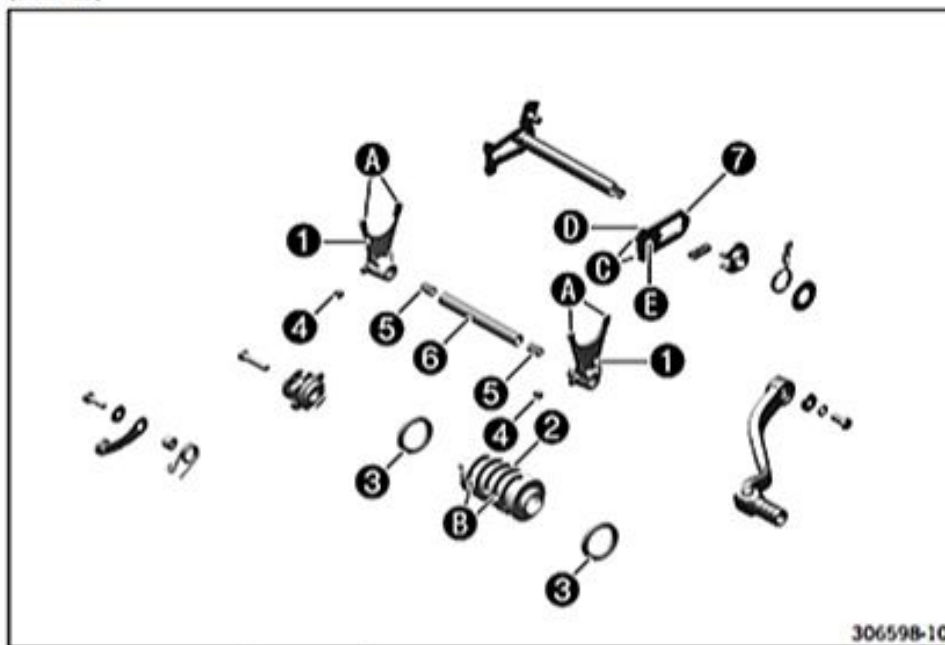

306598-10

- Check shift forks **1** at leaf **A** for wear.

Shift fork	
Thickness at leaf	4.85... 4.95 mm (0.1909... 0.1949 in)

- If the measured value does not meet specifications:
 - Change the shift fork.
- Check shift grooves **B** of shift drum **2** for wear.
 - If the shift groove is worn:
 - Change the shift drum.
- Check the seat of the shift drum in bearing **3**.
 - If the shift drum is not correctly seated:
 - Change the shift drum and/or bearing.
- Check bearing **3** for stiffness and wear.
 - If the bearing does not move easily or is worn:
 - Change the bearing.
- Check shift rollers **4** for surface damage and cracking.
 - If the shift roller exhibits surface damage or cracking:
 - Change the shift drum.
- Check springs **5** of the shift rails for damage and wear.
 - If the spring is damaged or worn:

- Change the spring of the shift rail.
- Check shift rails **5** on a flat surface for run-out.
 - If there is run-out:
 - Change the shift rail.
- Check the shift rails for scoring, seizure marks, and stiffness in the shift fork.
 - If the shift rail has scoring, seizure marks, or does not move easily in the shift fork:
 - Change the shift rail.
- Check sliding plate **7** for wear on contact areas **6**.
 - If the sliding plate is worn:
 - Change the sliding plate.
- Check return surface **D** on the sliding plate for wear.
 - If there is severe grooving:
 - Change the sliding plate.
- Check guide bolts **E** for firm seating and wear.
 - If the guide bolts are loose or worn:
 - Change the sliding plate.
- Preassemble the shift shaft. (☛ p. 190)

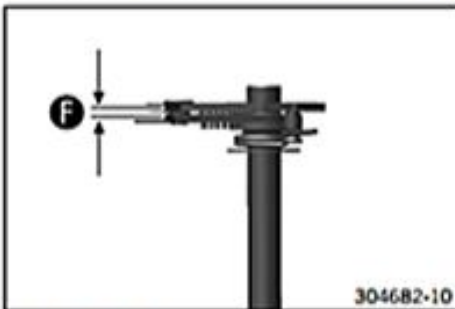

- Check clearance **F** between the sliding plate and the shift quadrant.

Shift shaft - play in sliding plate/shift quadrant	0.4... 0.8 mm (0.016... 0.031 in)
--	-----------------------------------

- If the measured value does not meet specifications:
 - Change the sliding plate.

(SX-F USA, XC-F)

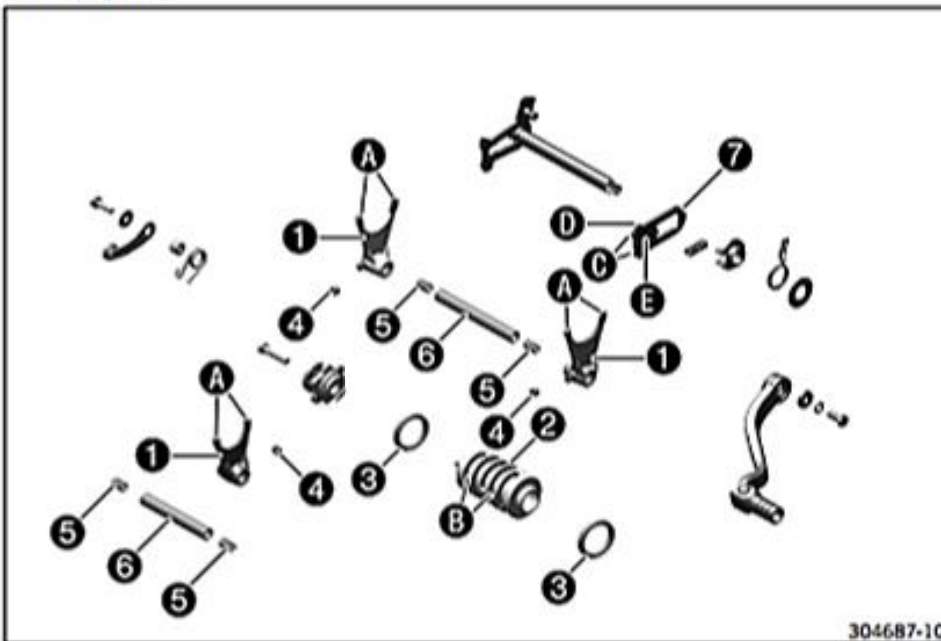

- Check shift forks **1** at leaf **A** for wear.

Shift fork	
Thickness at leaf	4.85... 4.95 mm (0.1909... 0.1949 in)

- If the measured value does not meet specifications:
 - Change the shift fork.
- Check shift grooves **B** of shift drum **2** for wear.
 - If the shift groove is worn:

- Change the shift drum.
- Check the seat of the shift drum in bearing ③.
 - If the shift drum is not correctly seated:
 - Change the shift drum and/or bearing.
- Check bearing ③ for stiffness and wear.
 - If the bearing does not move easily or is worn:
 - Change the bearing.
- Check shift rollers ④ for surface damage and cracking.
 - If the shift roller exhibits surface damage or cracking:
 - Change the shift drum.
- Check springs ⑤ of the shift rails for damage and wear.
 - If the spring is damaged or worn:
 - Change the spring of the shift rail.
- Check shift rails ⑥ on a flat surface for run-out.
 - If there is run-out:
 - Change the shift rail.
- Check the shift rails for scoring, seizure marks, and stiffness in the shift fork.
 - If the shift rail has scoring, seizure marks, or does not move easily in the shift fork:
 - Change the shift rail.
- Check sliding plate ⑦ for wear on contact areas ⑧.
 - If the sliding plate is worn:
 - Change the sliding plate.
- Check return surface ⑩ on the sliding plate for wear.
 - If there is severe grooving:
 - Change the sliding plate.
- Check guide bolts ⑨ for firm seating and wear.
 - If the guide bolts are loose or worn:
 - Change the sliding plate.
- Preassemble the shift shaft. (↖ p. 190)

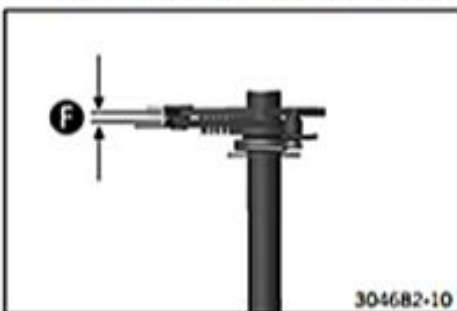

- Check clearance F between the sliding plate and the shift quadrant.

Shift shaft - play in sliding plate/shift quadrant	0.4... 0.8 mm (0.016... 0.031 in)
--	-----------------------------------

- If the measured value does not meet specifications:
 - Change the sliding plate.

16.4.35 Preassembling the shift shaft

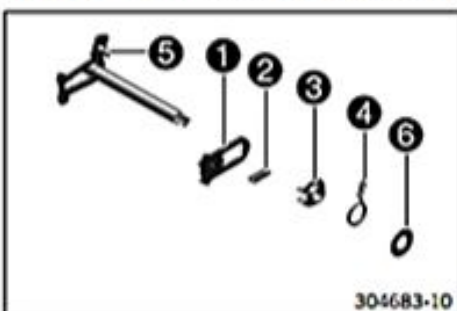

- Secure the short end of the shift shaft in the bench vise.

Guideline

Use soft jaws.

- Mount sliding plate ① with the guide pin facing downward and put the guide pin on the shift quadrant.
- Mount pressure spring ②.
- Slide on spring guide ③, push return spring ④, with the offset end facing upward, over the spring guide and lift the offset end over abutment bolt ⑤.
- Mount stop disk ⑥.

16.4.36 Disassembling the main shaft

(SX-F EU)

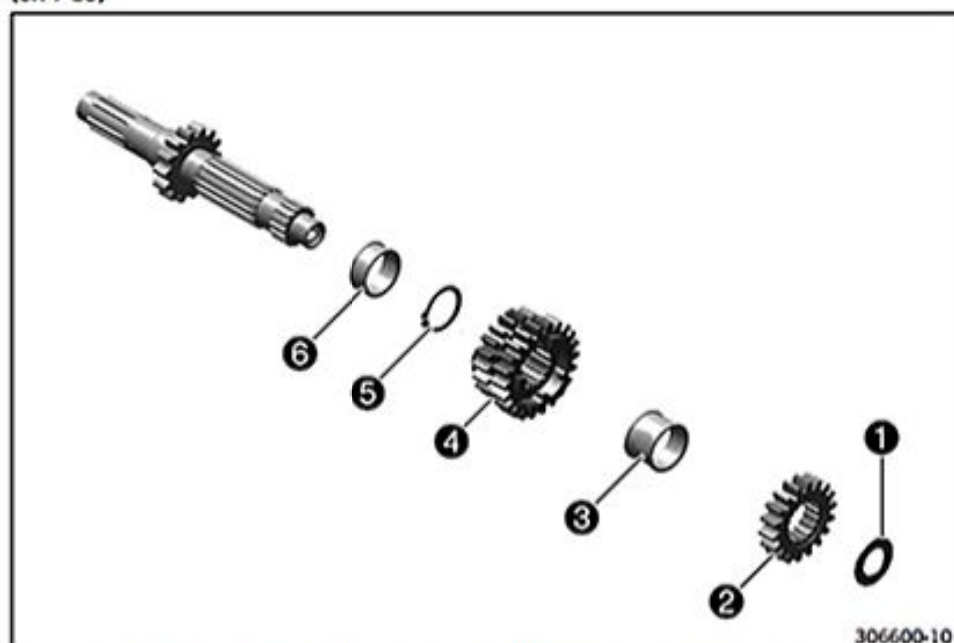

- Secure the main shaft with the toothed end facing downward in the vise.

Guideline

Use soft jaws.

- Remove stop disk ① and 2nd-gear fixed gear ②.
- Remove distance sleeve ③.
- Remove 3rd/4th-gear sliding gear ④.
- Remove lock ring ⑤.
- Remove distance sleeve ⑥.

(SX-F USA, XC-F)

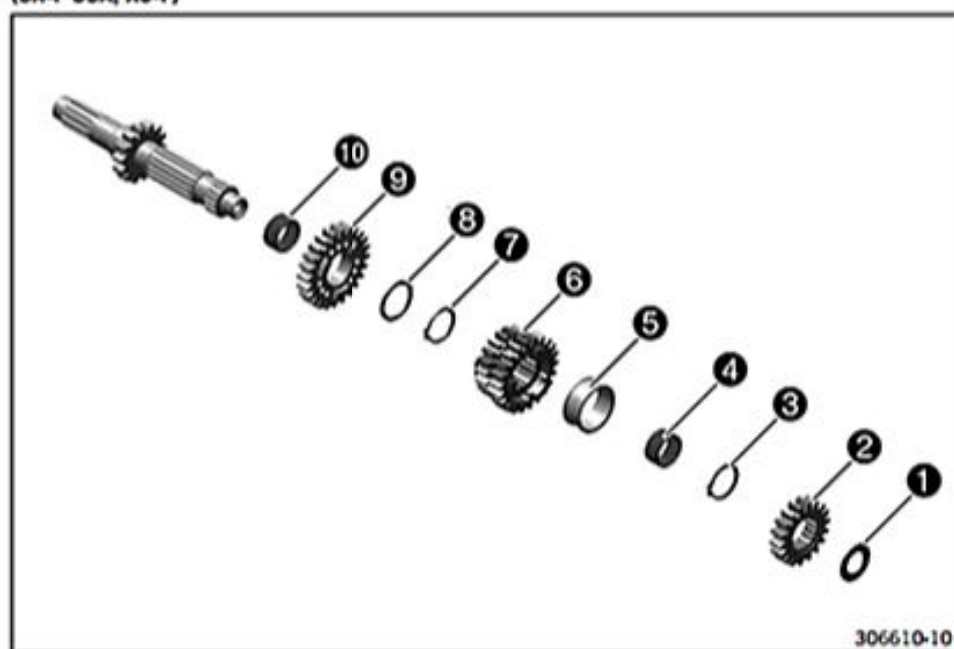

- Secure the main shaft with the toothed end facing downward in the vise.

Guideline

Use soft jaws.

- Remove stop disk ① and 2nd-gear fixed gear ②.
- Remove lock ring ③.

- Remove needle bearing ④ and distance sleeve ⑤.
- Remove 3rd/4th-gear sliding gear ⑥.
- Remove lock ring ⑦ and stop disk ⑧.
- Remove 5th-gear idler gear ⑨.
- Remove needle bearing ⑩.

16.4.37 Disassembling the countershaft

(SX-F EU)

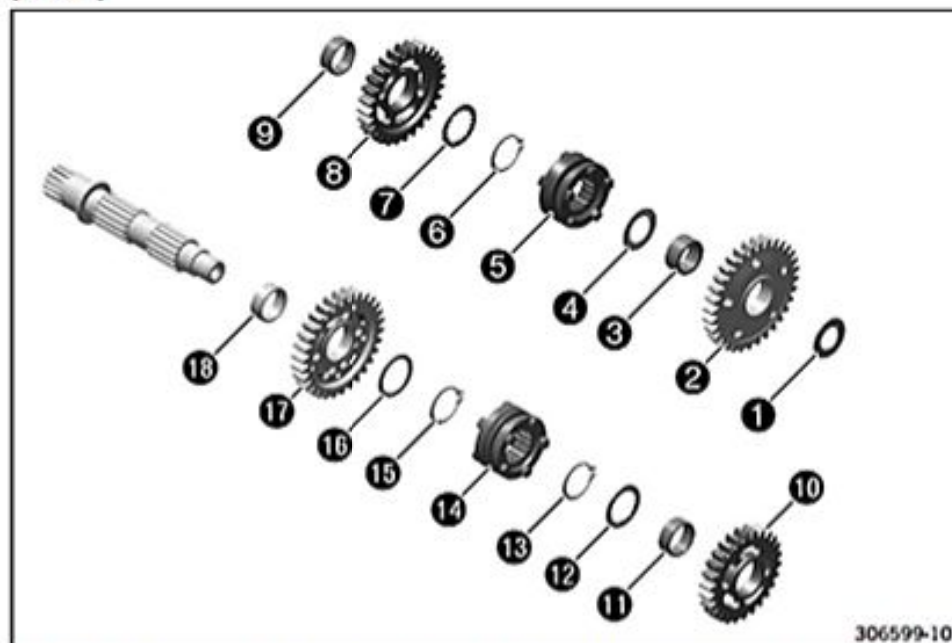

- Fix the countershaft in the vice with the toothed end facing downward.

Guideline

Use soft jaws

- Remove stop disk ① and 1st-gear idler gear ②.
- Remove needle bearing ③ and stop disk ④.
- Remove 1st/3rd-gear shift collar ⑤ and lock ring ⑥.
- Remove stop disk ⑦ and 3rd-gear idler gear ⑧.
- Remove needle bearing ⑨ and 4th-gear idler gear ⑩.
- Remove needle bearing ⑪ and stop disk ⑫.
- Remove lock ring ⑬ and 2nd/4th gear shift collar ⑭.
- Remove lock ring ⑮ and stop disk ⑯.
- Remove 2nd-gear idler gear ⑰ and needle bearing ⑱.

(SX-F USA, XC-F)

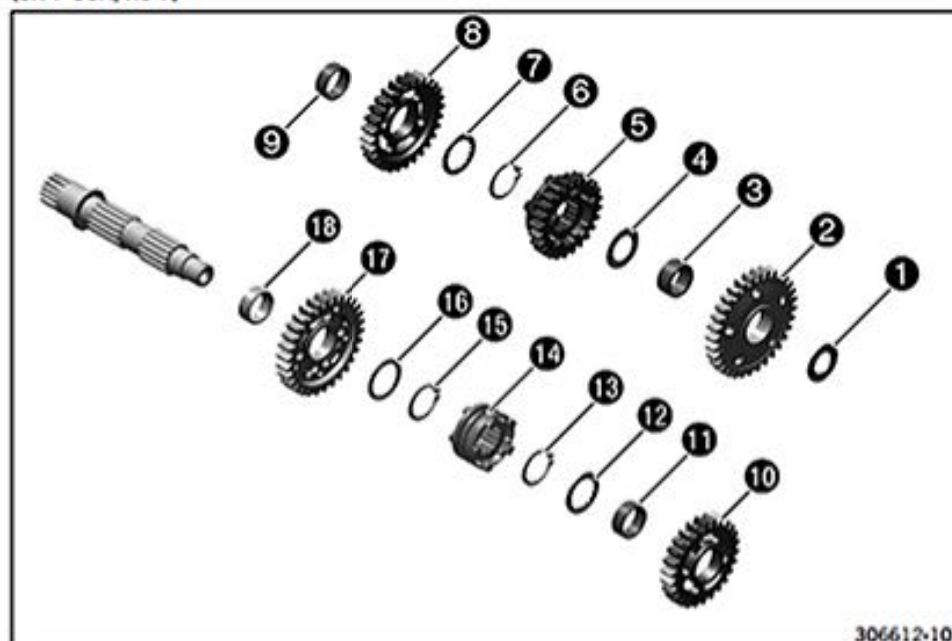

- Fix the countershaft in the vice with the toothed end facing downward.

Guideline

Use soft jaws

- Remove stop disk ① and 1st-gear idler gear ②.
- Remove needle bearing ③ and stop disk ④.
- Remove 5th-gear sliding gear ⑤ and lock ring ⑥.
- Remove stop disk ⑦ and 3rd-gear idler gear ⑧.
- Remove needle bearing ⑨ and 4th-gear idler gear ⑩.
- Remove needle bearing ⑪ and stop disk ⑫.
- Remove lock ring ⑬ and 2nd/4th gear shift collar ⑭.
- Remove lock ring ⑮ and stop disk ⑯.
- Remove 2nd-gear idler gear ⑰ and needle bearing ⑱.

16.4.38 Checking the transmission

Condition

The transmission has been disassembled.

(SX-F EU)

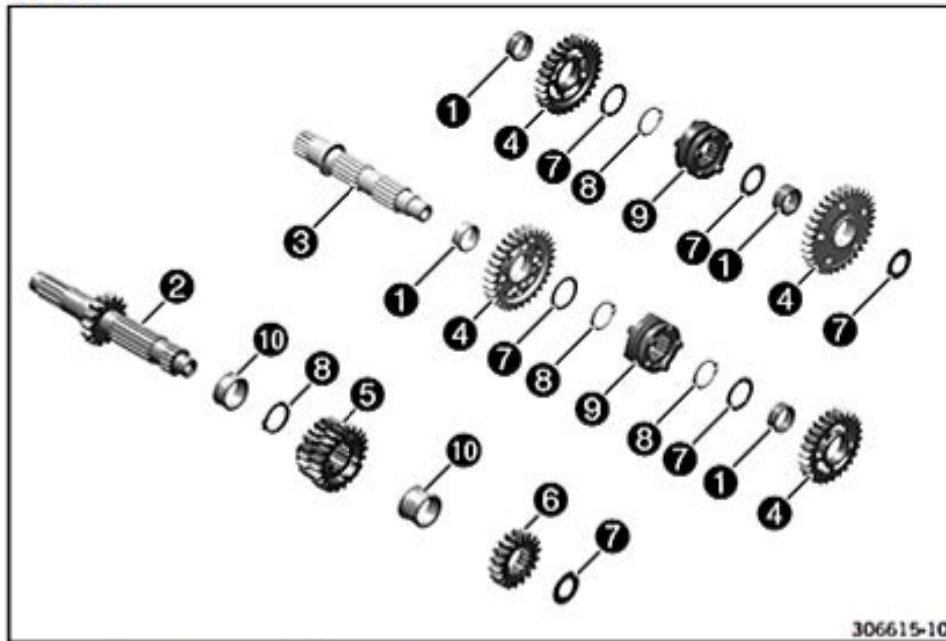

306615-10

- Check needle bearings **1** for damage and wear.
 - If there is damage or wear:
 - Change the needle bearings.
- Check the pivot points of main shaft **2** and countershaft **3** for damage and wear.
 - If there is damage or wear:
 - Change the main shaft and/or countershaft.
- Check the tooth profiles of main shaft **2** and countershaft **3** for damage and wear.
 - If there is damage or wear:
 - Change the main shaft and/or countershaft.
- Check the pivot points of idler gears **4** for damage and wear.
 - If there is damage or wear:
 - Change the gear wheel pair.
- Check the shift dogs of idler gears **4**, of shift collars **9**, and of sliding gear **5** for damage and wear.
 - If there is damage or wear:
 - Change the gear wheel pair or shift collar.
- Check the tooth faces of idler gears **4**, of sliding gear **5**, and of fixed gear **6** for damage and wear.
 - If there is damage or wear:
 - Change the gear wheel pair.
- Check the tooth profiles of sliding gear **5** for damage and wear.
 - If there is damage or wear:
 - Change the gear wheel pair.
- Check sliding gear **5** for smooth operation in the profile of main shaft **2**.
 - If the sliding gear does not move freely:
 - Change the sliding gear or the main shaft.
- Check shift collars **9** for damage and wear.
 - If there is damage or wear:
 - Change the shift collars.
- Check shift collars **9** for smooth operation in the profile of the countershaft **3**.
 - If the shift collar is stiff:
 - Change the shift collar or countershaft.
- Check stop disks **7** for damage and wear.
 - If there is damage or wear:
 - Change the stop disks.

- Use new lock rings **8** with every repair.
- Check distance sleeves **10** for damage and wear.
 - If there is damage or wear:
 - Change the distance sleeves.

(SX-F USA, XC-F)

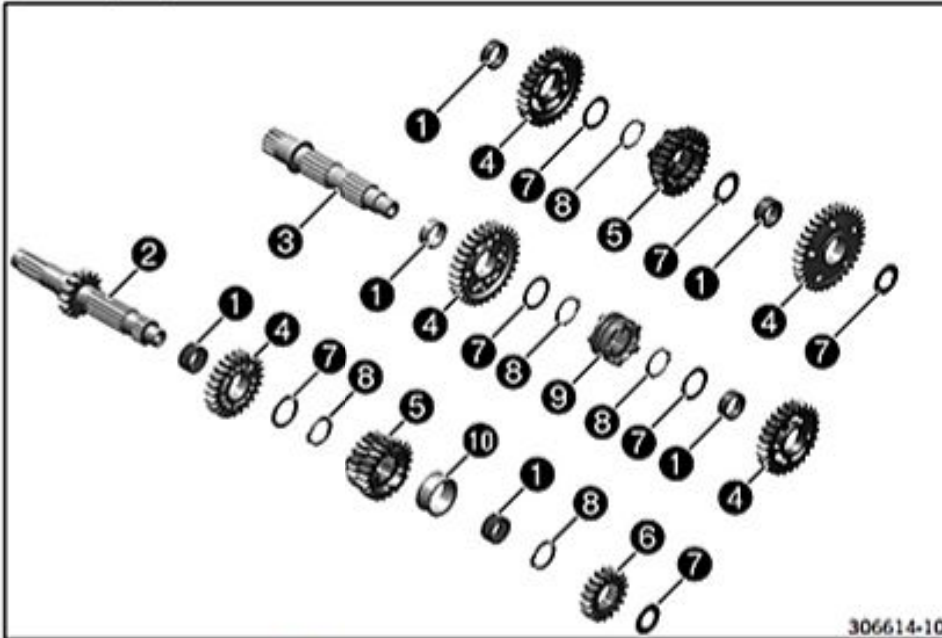

- Check needle bearings **1** for damage and wear.
 - If there is damage or wear:
 - Change the needle bearings.
- Check the pivot points of main shaft **2** and countershaft **3** for damage and wear.
 - If there is damage or wear:
 - Change the main shaft and/or countershaft.
- Check the tooth profiles of main shaft **2** and countershaft **3** for damage and wear.
 - If there is damage or wear:
 - Change the main shaft and/or countershaft.
- Check the pivot points of idler gears **4** for damage and wear.
 - If there is damage or wear:
 - Change the gear wheel pair.
- Check the shift dogs of idler gears **4** and sliding gears **5** for damage and wear.
 - If there is damage or wear:
 - Change the gear wheel pair.
- Check the tooth faces of idler gears **4**, sliding gears **5**, and fixed gear **6** for damage and wear.
 - If there is damage or wear:
 - Change the gear wheel pair.
- Check the tooth profiles of sliding gears **5** for damage and wear.
 - If there is damage or wear:
 - Change the gear wheel pair.
- Check sliding gear **5** for smooth operation in the profile of main shaft **2**.
 - If the sliding gear does not move freely:
 - Change the sliding gear or the main shaft.
- Check shift collar **9** for damage and wear.
 - If there is damage or wear:
 - Change the shift collar.
- Check sliding gear **5** and shift collar **9** for smooth operation in the profile of countershaft **3**.

- ▶ If the sliding gear or shift collar is stiff:
 - Change the sliding gear, shift collar, or countershaft.
- Check stop disks **7** for damage and wear.
 - ▶ If there is damage or wear:
 - Change the stop disks.
- Use new lock rings **8** with every repair.
- Check distance sleeves **10** for damage and wear.
 - ▶ If there is damage or wear:
 - Change the distance sleeves.

16.4.39 Assembling the main shaft



Info

Use new lock rings with every repair.

Preparatory work

- Carefully grease all parts before assembling.
- Check the transmission. (☛ p. 193)

Main work

(SX-F EU)

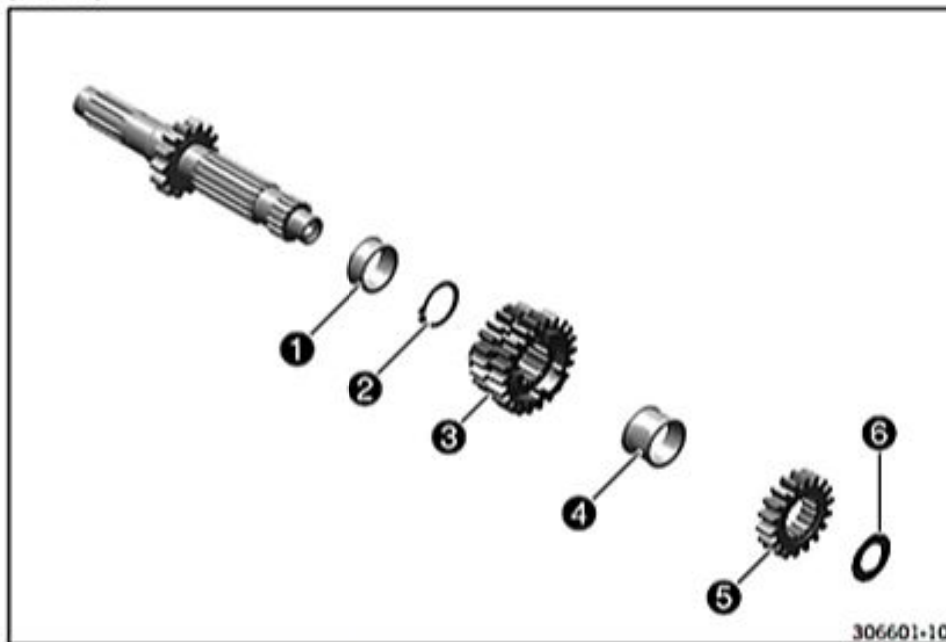

306601-10

- Secure the main shaft with the toothed end facing downward in the vise.

Guideline

Use soft jaws

- Mount distance sleeve **1** and lock ring **2**.
- Mount 3rd/4th-gear sliding gear **3** with the small gear wheel facing downward.
- Mount distance sleeve **4**.
- Attach 2nd-gear fixed gear **5** with the collar facing downward and stop disk **6**.
- Finally, check all gear wheels for smooth operation.

(SX-F USA, XC-F)

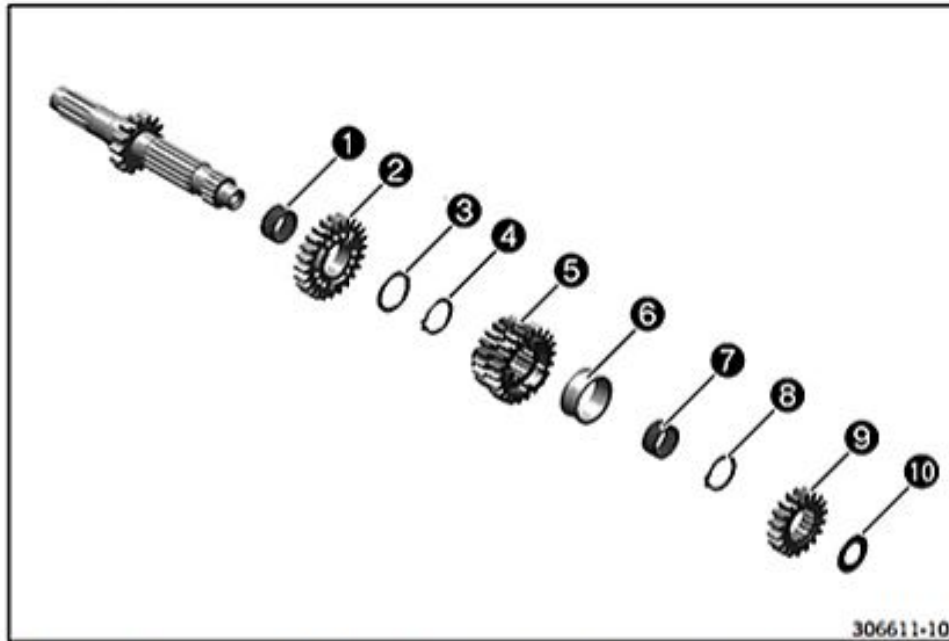

- Secure the main shaft with the toothed end facing downward in the vise.

Guideline

Use soft jaws

- Mount needle bearing ①, attach 5th-gear idler gear ② with the shift dogs facing upward.
- Mount stop disk ③ and lock ring ④.
- Mount 3rd/4th-gear sliding gear ⑤ with the small gear wheel facing downward.
- Mount distance sleeve ⑥ and needle bearing ⑦.
- Mount lock ring ⑧.
- Mount 2nd-gear fixed gear ⑨ with the collar facing downward and stop disk ⑩.
- Finally, check all gear wheels for smooth operation.

16.4.40 Assembling the countershaft



Info

Use new lock rings with every repair.

Preparatory work

- Carefully grease all parts before assembling.
- Check the transmission. (☛ p. 193)

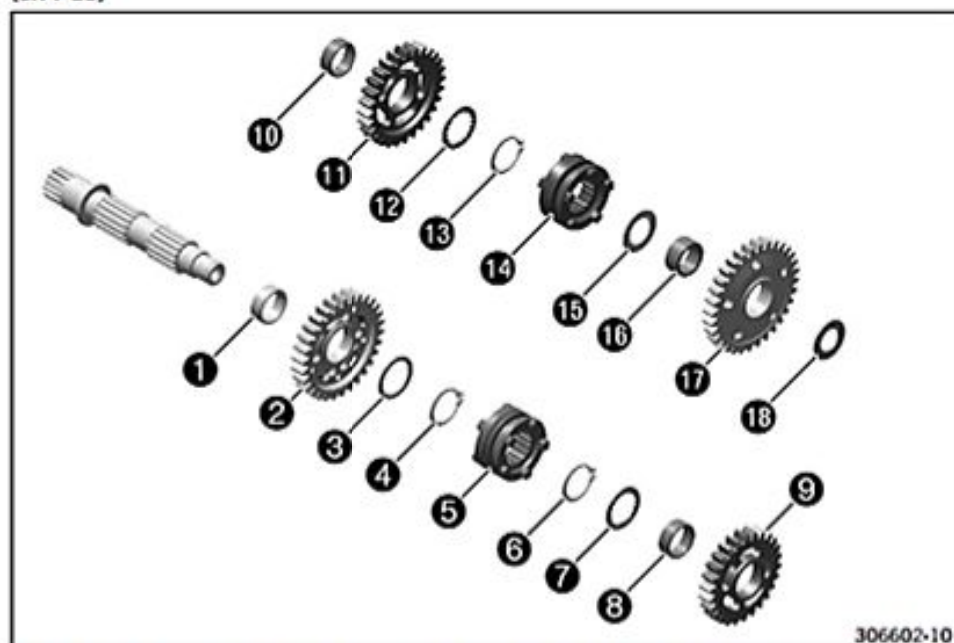
Main work
(SX-F EU)

306602-10

- Fix the countershaft in the vice with the toothed end facing downward.

Guideline

Use soft jaws

- Mount needle bearing ① and 2nd-gear idler gear ② onto the countershaft with the protruding collar facing downward.
- Mount stop disk ③ and lock ring ④.
- Mount 2nd/4th gear shift collar ⑤ with the shift groove facing up.
- Mount lock ring ⑥ and stop disk ⑦.
- Mount needle bearing ⑧ and the 4th-gear idler gear ⑨ with the collar facing up.
- Mount needle bearing ⑩ and the 3rd-gear idler gear ⑪ with the collar facing down.
- Mount stop disk ⑫ and lock ring ⑬.
- Mount the 1st/3rd-gear shift collar ⑭ with the shift groove facing downward and stop disk ⑮.
- Mount needle bearing ⑯, 1st-gear idler gear ⑰ with the recess facing down and stop disk ⑱.
- Finally, check all gear wheels for smooth operation.

(SX-F USA, XC-F)

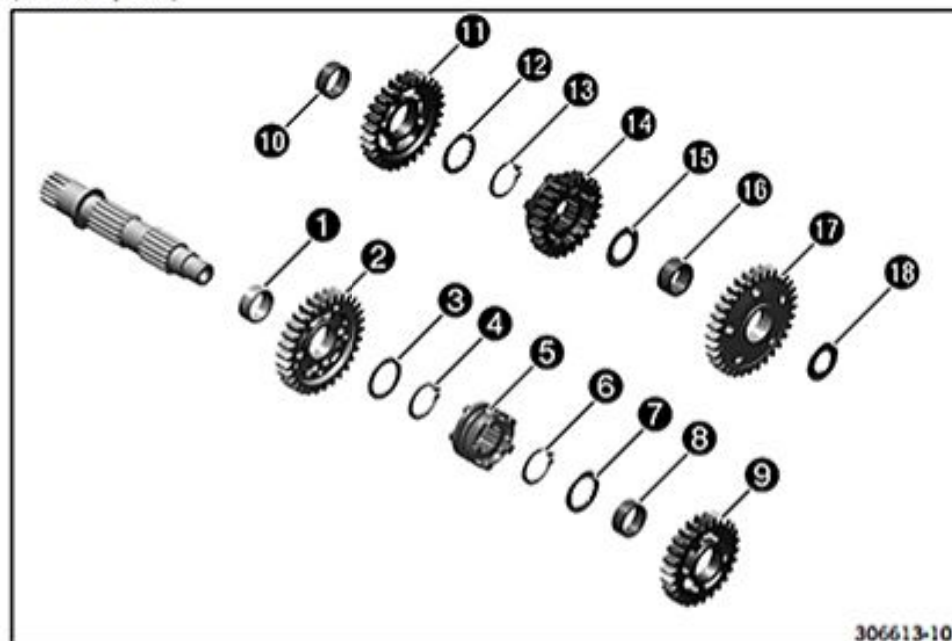

- Fix the countershaft in the vice with the toothed end facing downward.

Guideline

Use soft jaws

- Mount needle bearing ① and 2nd-gear idler gear ② onto the countershaft with the protruding collar facing downward.
- Mount stop disk ③ and lock ring ④.
- Mount 2nd/4th gear shift collar ⑤ with the shift groove facing up.
- Mount lock ring ⑥ and stop disk ⑦.
- Mount needle bearing ⑧ and the 4th-gear idler gear ⑨ with the collar facing up.
- Mount needle bearing ⑩ and the 3rd-gear idler gear ⑪ with the collar facing down.
- Mount stop disk ⑫ and lock ring ⑬.
- Mount the 5th-gear sliding gear ⑭ with the shift groove facing down and stop disk ⑮.
- Mount needle bearing ⑯, 1st-gear idler gear ⑰ with the recess facing down and stop disk ⑱.
- Finally, check all gear wheels for smooth operation.

16.4.41 Checking the starter drive

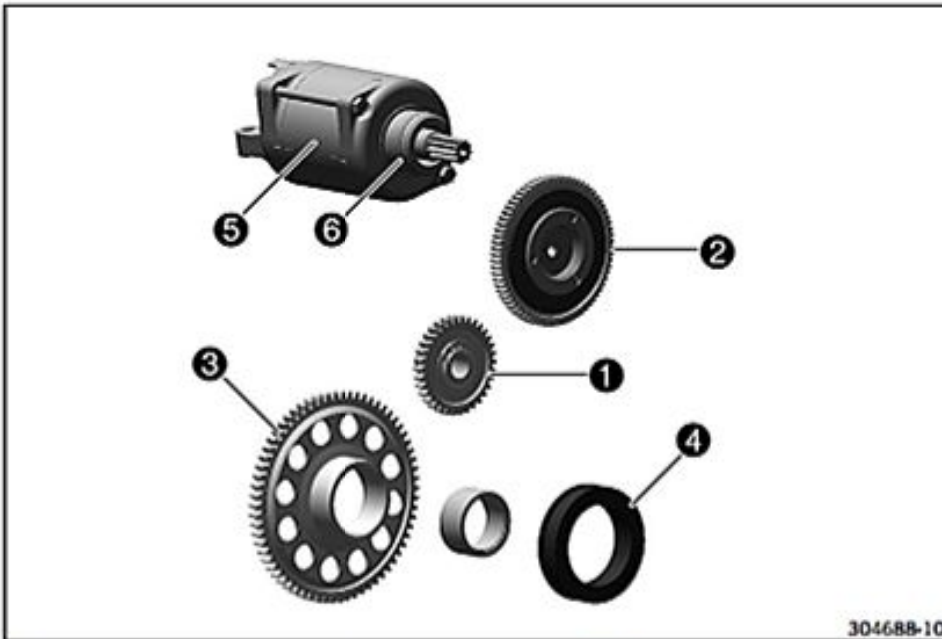

304688-10

- Check the gear mesh and bearing of starter idler gear **1** for damage and wear.
 - If there is damage or wear:
 - Change the starter idler gear.
- Check the gear mesh and bearing of torque limiter **2** for damage and wear.
 - If there is damage or wear:
 - Change the torque limiter.
- Check the gear mesh and bearing of freewheel gear **3** for damage and wear.
 - If there is damage or wear:
 - Change the freewheel gear or bearing.
- Check freewheel **4** for damage and wear when it is disassembled.
 - If there is damage or wear:
 - Change the freewheel.
- Check the gear mesh of starter motor **5** for damage and wear.
 - If there is damage or wear:
 - Change the starter motor.
- Change the O-ring **6** of the starter motor.
- Connect the negative cable of a 12 volt power supply to the housing of the starter motor. Connect the positive cable of the power supply briefly with connector of the starter motor.
 - If the starter motor does not turn when the circuit is closed:
 - Change the starter motor.

16.4.42 Checking the freewheel

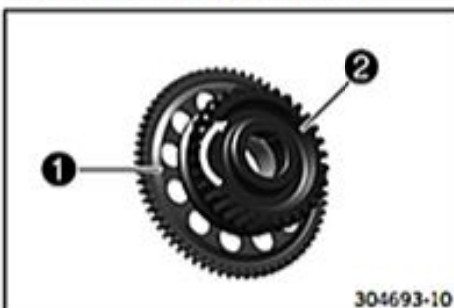

304693-10

- Insert freewheel gear **1** into primary gear **2**, turning the primary gear clockwise; do not wedge!
- Check the locking action of freewheel gear **1**.
 - If the primary gear does not turn clockwise or if it does not lock counterclockwise:
 - Remove the freewheel. (☞ p. 201)
 - Turn the freewheel 180°.
 - Install the freewheel. (☞ p. 201)

16.4.43 Removing the freewheel

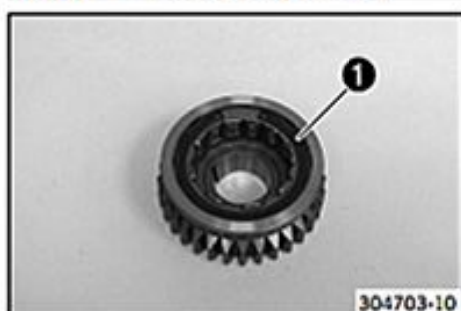

304703-10

- Press expansion ring 1 together with suitable pliers and take off.

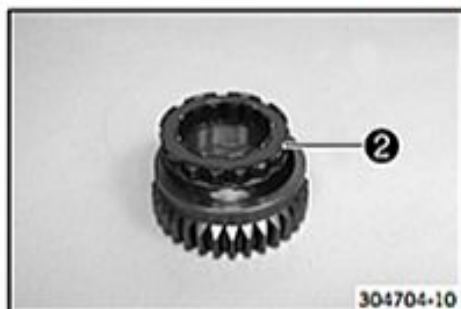

304704-10

- Take the freewheel 2 out of the primary gear.

16.4.44 Installing the freewheel



304704-11

- Thoroughly oil all parts.
- Push the freewheel 1 into the primary gear.

**Info**

Note the direction of rotation.

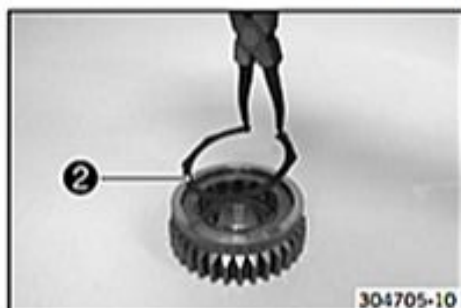

304705-10

- Mount spreader ring 2.

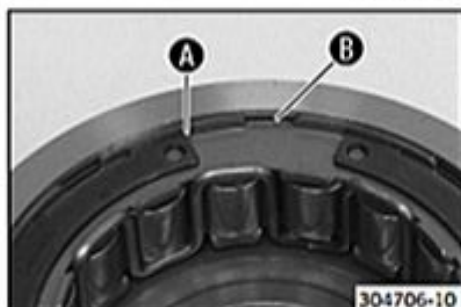

304706-10

- Ensure that all lugs of the spreader ring pass through slots A of the freewheel and engage in groove B of the primary gear.

16.5 Engine assembly

16.5.1 Installing the crankshaft

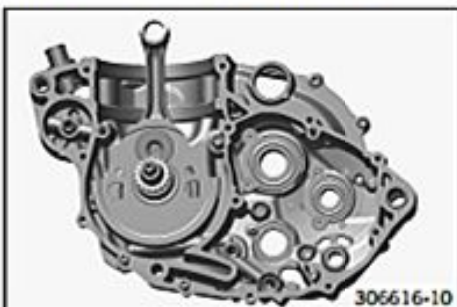

- Tighten the right section of the engine case in the engine assembly stand.
- Heat the crankshaft bearing.

Guideline

80 °C (176 °F)



Info

Do not damage the seal ring.

- Mount the special tool on the clutch end of the crankshaft.

Mounting sleeve (78029005000) (☛ p. 269)

- Push the crankshaft all the way into the bearing seat of the right section of the engine case.
- Remove the special tool.

16.5.2 Installing the transmission shafts

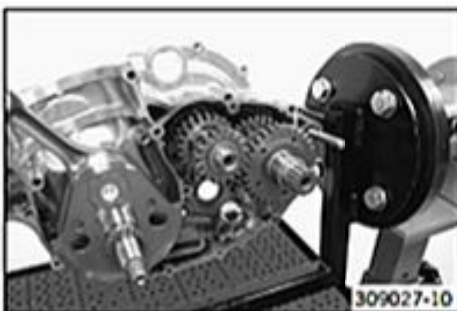

(SX-F EU)

- Lubricate all bearings.
- Slide both transmission shafts into the bearing seats.



Info

Make sure not to misplace the washers.

- Mount lock ring ①.

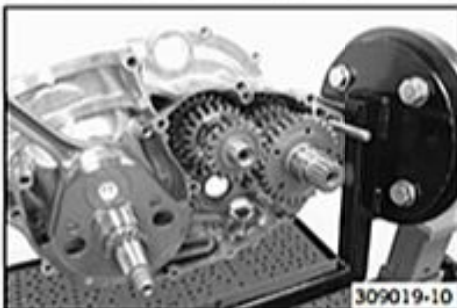
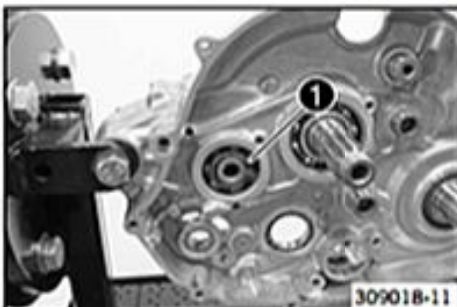

(SX-F USA, XC-F)

- Lubricate all bearings.
- Slide both transmission shafts into the bearing seats.



Info

Make sure not to misplace the washers.

- Mount lock ring ①.



16.5.3 Installing the shift forks

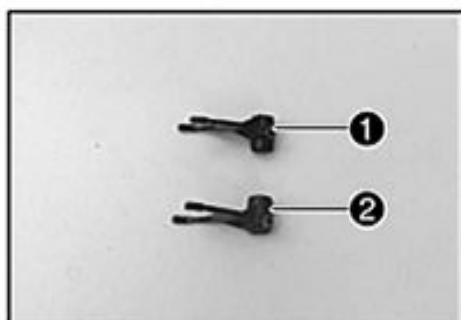

(SX-F EU)

- Lubricate all parts thoroughly.
- Mount shift fork **1** in the upper shift groove of the countershaft.
- Mount shift fork **2** in the lower shift groove of the countershaft.
- Slide on shift rollers **3**.



Info

Fix the shift rollers in the shift forks with grease.

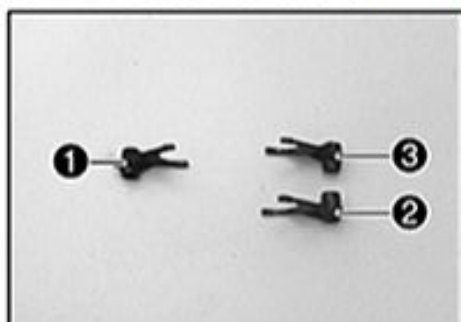

(SX-F USA, XC-F)

- Lubricate all parts thoroughly.
- Mount shift fork **1** in the upper shift groove of the main shaft.
- Mount shift fork **2** in the lower shift groove of the countershaft.
- Mount shift fork **3** in the upper shift groove of the countershaft.
- Mount shift rollers **4**.



Info

Fix the shift rollers in the shift forks with grease.

16.5.4 Installing the shift drum

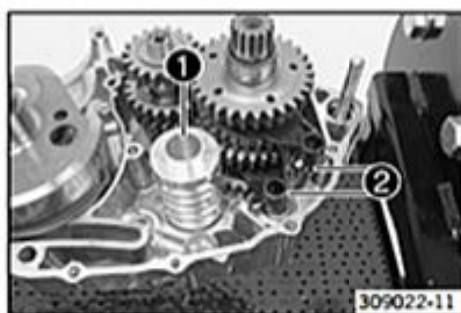

(SX-F EU)

- Push shift drum **1** into the bearing seat.
- Put shift forks **2** in the shift drum.



Info

Do not misplace the shift rollers.

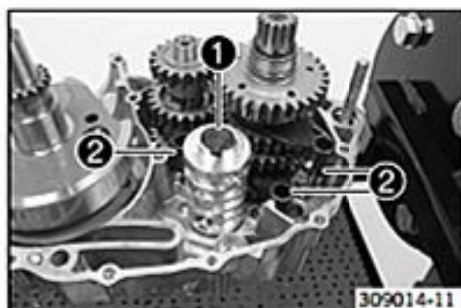

(SX-F USA, XC-F)

- Push shift drum **1** into the bearing seat.
- Put shift forks **2** in the shift drum.

**Info**

Do not misplace the shift rollers.

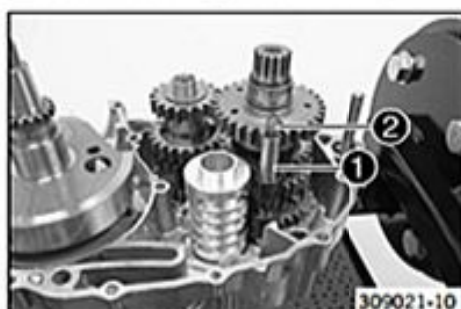
16.5.5 Installing the shift rails

(SX-F EU)

- Install shift rail **1** together with upper spring **2** and the lower spring.

**Info**

Fix the springs in the shift rail with grease.

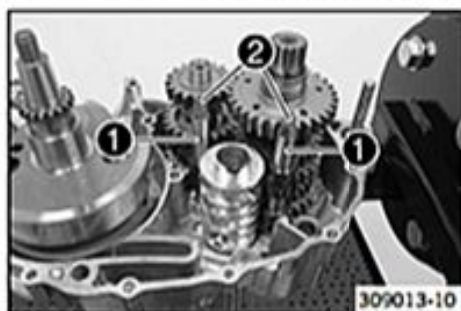

(SX-F USA, XC-F)

- Install shift rails **1** together with upper springs **2** and lower springs.

**Info**

Fix the springs in the shift rails with grease.

16.5.6 Installing the left engine case

(SX-F EU)

- Mount dowels **1** onto the left section of the engine case.
- Grease the sealing surfaces. Apply the sealing compound to the left section of the engine case.

Loctite® 5910

**Info**To prevent sealing compound from entering into the oil channels, dowels **1** must be mounted first.



(SX-F USA, XC-F)

- Mount dowels **1** onto the left section of the engine case.
- Grease the sealing surfaces. Apply the sealing compound to the left section of the engine case.

Loctite® 5910

**Info**

To prevent sealing compound from entering into the oil channels, dowels **1** must be mounted first.



309012-10

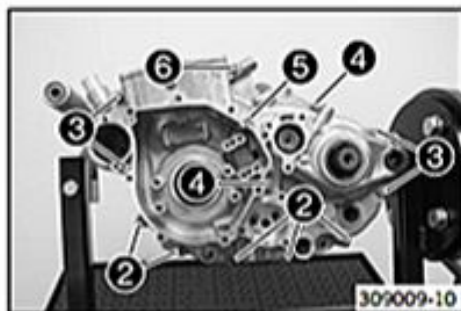

309009-10

- Mount the left engine casing. If necessary, strike it lightly with a rubber mallet.

**Info**

Do not use the screws to pull the two sections of the engine case together.

- Mount screws **2** but do not tighten them yet.

Guideline

Screw, engine case	M6x40	10 Nm (7.4 lbf ft)
--------------------	-------	--------------------

- Mount screws **3** but do not tighten them yet.

Guideline

Screw, engine case	M6x60	10 Nm (7.4 lbf ft)
--------------------	-------	--------------------

- Mount screws **4** but do not tighten them yet.

Guideline

Screw, engine case	M6x75	10 Nm (7.4 lbf ft)
--------------------	-------	--------------------

- Mount screw **5** but do not tighten yet.

Guideline

Screw, engine case	M6x80	10 Nm (7.4 lbf ft)
--------------------	-------	--------------------

- Mount screw **6** and tighten all screws in a crisscross pattern.

Guideline

Screw, engine case	M6x85	10 Nm (7.4 lbf ft)
--------------------	-------	--------------------

- Mount the O-ring on the countershaft.
- Lightly grease and mount spacer **7**.

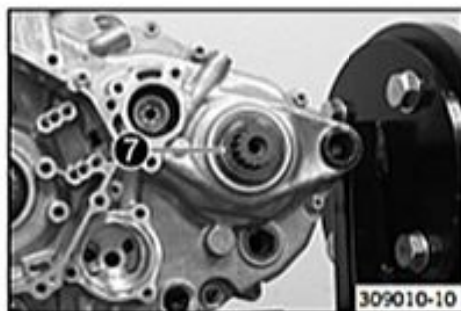

309010-10

16.5.7 Installing the freewheel gear



- Mount freewheel gear ①.

16.5.8 Installing the primary gear

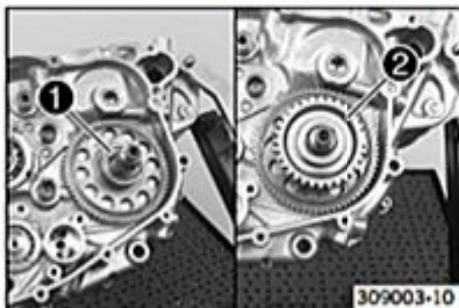

- Mount spring washer ①.
- Degrease the cone and thinly apply thread locker to it.

Loctite® 648™

- Mount primary gear ②.



Info

Turn the freewheel gear to ease engagement.

16.5.9 Installing the force pump

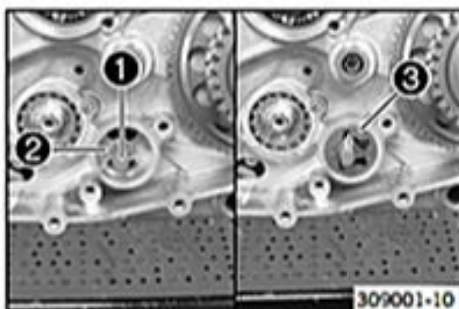

- Oil the oil pump shaft, internal rotor and external rotor before assembly.
- Mount oil pump shaft ①.
- Mount pin ②.
- Mount the internal rotor with the recess facing inward.
- Mount external rotor ③ with the bevel facing inward.

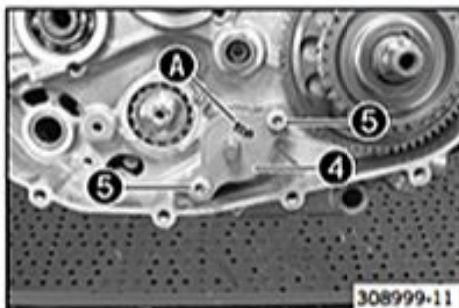

- Position oil pump cover ④.
- ✓ The Top marking A faces up.
- Mount and tighten screws ⑤.

Guideline

Screw, pressure pump cover	M6	10 Nm (7.4 lbf ft)	Loctite® 243™
----------------------------	----	-----------------------	---------------

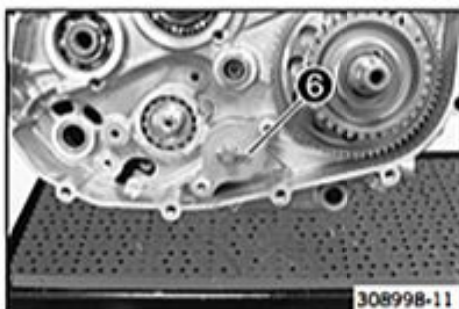

- Insert pin ⑥.

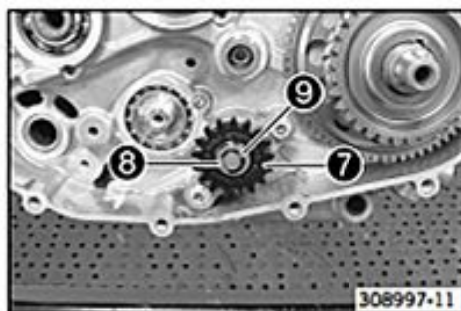

- Position oil pump gear wheel **7**.
- Position washers **8**.
- Mount lock washer **9**.



- Mount oil pump idler gear **10**.
- Mount washer **11** and lock ring **12**.
- Crank the oil pump gear wheels and ensure that they can move easily.

16.5.10 Installing the locking lever

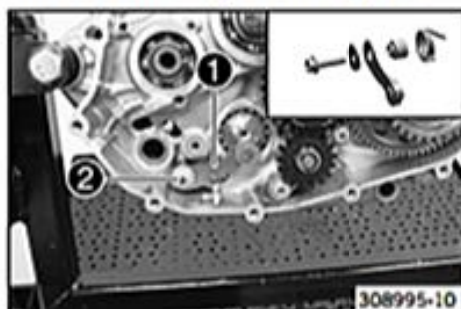

- Mount locking lever **1** with the washer, sleeve and spring.
- Mount and tighten screw **2**.

Guideline

Screw, locking lever	M5	6 Nm (4.4 lbf ft)	Loctite® 243™
----------------------	----	----------------------	---------------

16.5.11 Installing the shift drum locating unit

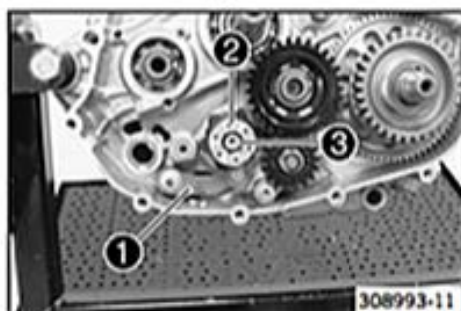

- Push away locking lever **1** from the shift drum locating unit and position the shift drum locating unit **2**.



Info

The flat areas of the shift drum locating unit are not symmetric.

- Relieve tension from the locking lever.
- Mount and tighten screw **3**.

Guideline

Screw, shift drum locating	M6	10 Nm (7.4 lbf ft)	Loctite® 243™
----------------------------	----	-----------------------	---------------

16.5.12 Installing the shift shaft

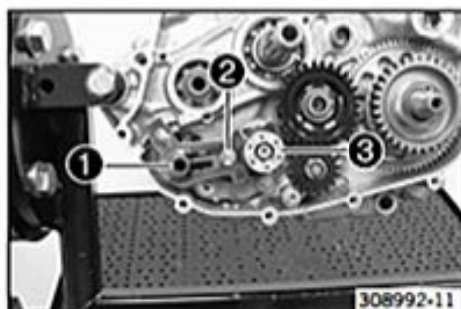

- Slide shift shaft **1** with the washer into the bearing seat.
- Push sliding plate **2** away from the shift drum locating unit and insert the shift shaft all the way.
- Let the sliding plate engage in the shift drum locating unit **3**.
- Shift through the transmission.

16.5.13 Installing the starter idler gear



- Slide on starter idler gear **1** with the collar facing the engine case.
- Position the washer and mount the lock ring.

16.5.14 Installing the torque limiter



- Position the washer.
- Mount the torque limiter.
- Mount and tighten screw **1** with the washer.

Guideline

Screw, bearing bolt, torque limiter	M6	10 Nm (7.4 lbf ft)	Loctite® 243™
-------------------------------------	----	-----------------------	---------------

16.5.15 Installing the outer clutch hub



- Mount collar bushing **1** and both needle bearings **2**.



- Slide the outer clutch hub **3** onto the gearbox main shaft.
- Turn oil pump gear wheel **4** until the gear teeth of the clutch basket engage.

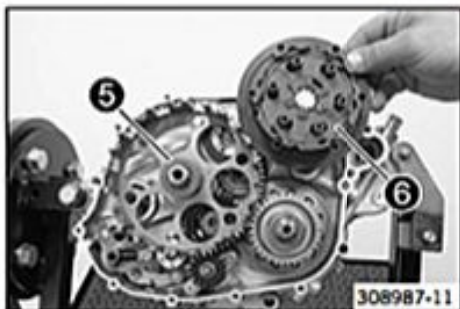

- Slide on washer **5** and inner clutch hub **6**.

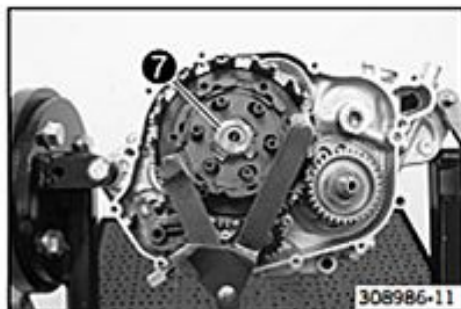

- Position the new lock washer and mount nut 7. Tighten the nut, holding the inner clutch hub with a special tool.

Guideline

Nut, inner clutch hub	M18x1.5	80 Nm (59 lbf ft)
-----------------------	---------	-------------------

Clutch holder (51129003000) (☞ p. 264)

- Secure the nut with the lock washer.



- Lock the outer clutch hub and primary gear using special tool 8.

Gear quadrant (80029004000) (☞ p. 270)

- Mount and tighten nut 9.

Guideline

Nut, primary gear	M20LHx1.5	100 Nm (73.8 lbf ft)	Loctite® 648™
-------------------	-----------	-------------------------	---------------

- Set the crankshaft to top dead center and lock it with special tool 10.

Locking screw (113080802) (☞ p. 262)

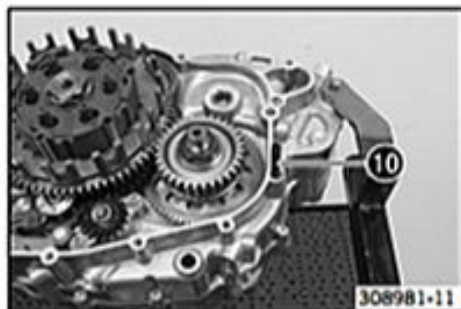

16.5.16 Installing the clutch discs

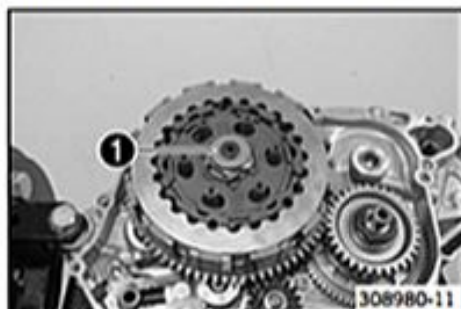

- Thoroughly oil the clutch facing discs.
- Beginning with an intermediate clutch disc, alternately insert all other clutch facing discs and intermediate clutch discs into the outer clutch hub.
- Mount pressure piece 1.

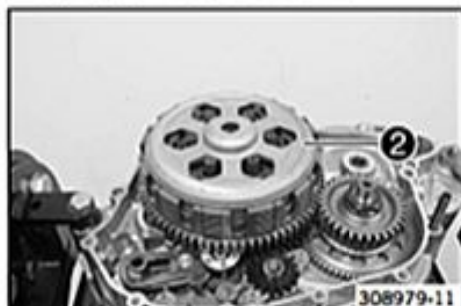

- Position pressure cap 2.

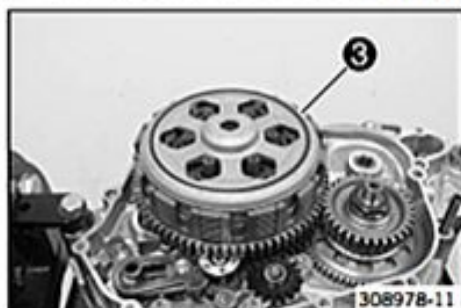

- Mount pretension ring 3 with the Top marking facing up.

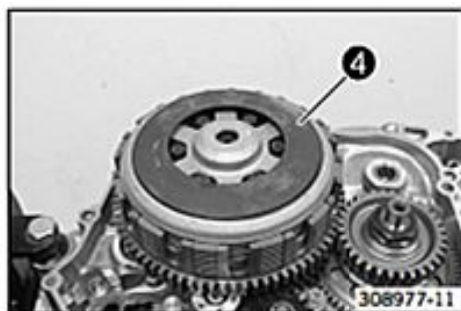

- Position spring washer **4**.

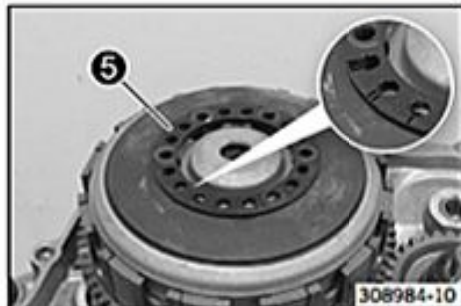

- Position spring retainer **5** with the I marking.



- Install the screws **6** and tighten them diagonally.

Guideline

Screw, clutch spring retainer	M5	6 Nm (4,4 lbf ft)
-------------------------------	----	-------------------



- Using a straightedge and the special tool, check the spring washer for distortion.

Feeler gauge (59029041100) (☞ p. 265)	
---------------------------------------	--

Spring washer distortion	0... 0.10 mm (0... 0.0039 in)
--------------------------	-------------------------------

- If the specified value is not reached:

- Remove screws **6** and mount spring retainer with marking II.

- Using a straightedge and the special tool, check the spring washer for distortion.

Feeler gauge (59029041100) (☞ p. 265)	
---------------------------------------	--

Spring washer distortion	0... 0.10 mm (0... 0.0039 in)
--------------------------	-------------------------------

- If the specified value is not reached:

- Remove screws **6** and mount spring retainer with marking III.

- Using a straightedge and the special tool, check the spring washer for distortion.

Feeler gauge (59029041100) (☞ p. 265)	
---------------------------------------	--

Spring washer distortion	0... 0.10 mm (0... 0.0039 in)
--------------------------	-------------------------------

- If the specified value is not reached:

- Change the clutch facing discs.

16.5.17 Installing the clutch cover

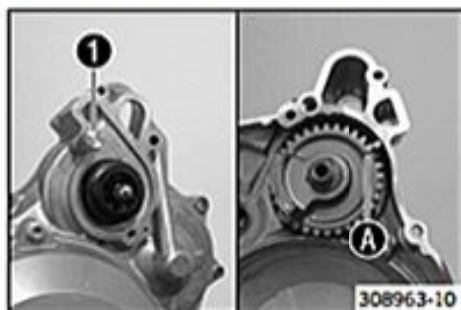

- Position the balancer shaft with special tool **1**.

Fixing drift (78129032000) (☞ p. 269)	
---------------------------------------	--

- ✓ Marking **A** and the special tool are aligned.

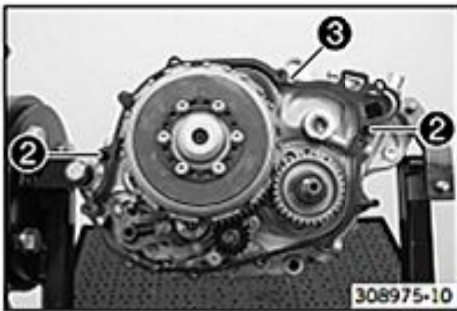

- Mount dowels **2** and position the clutch cover gasket **3**.

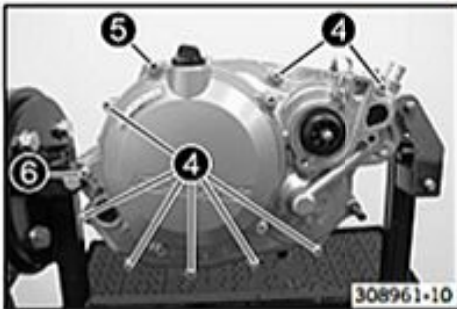

- Mount the clutch cover.
- Mount screws **4** but do not tighten them yet.

Guideline

Screw, clutch cover	M6x25	10 Nm (7.4 lbf ft)
---------------------	-------	--------------------

- Mount screw **5** but do not tighten yet.

Guideline

Screw, clutch cover	M6x55	10 Nm (7.4 lbf ft)
---------------------	-------	--------------------

- Mount screw **6** and tighten all screws in a crisscross pattern.

Guideline

Screw, clutch cover	M6x30	10 Nm (7.4 lbf ft)
---------------------	-------	--------------------

- Remove the special tool.

Fixing drift (78129032000) (☛ p. 269)

16.5.18 Installing the water pump cover

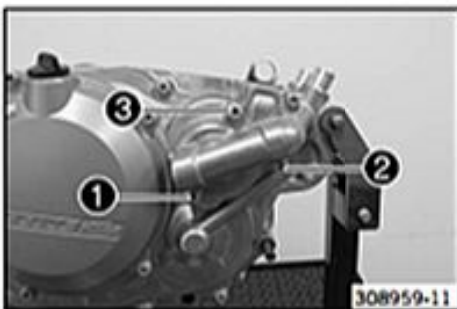

- Put the water pump cover seal in place.
- Mount the water pump cover.
- Mount screw **1** with the sealing washer but do not tighten yet.

Guideline

Screw, water pump cover	M6x25	10 Nm (7.4 lbf ft)
-------------------------	-------	--------------------

- Mount screw **2** but do not tighten yet.

Guideline

Screw, water pump cover	M6x25	10 Nm (7.4 lbf ft)
-------------------------	-------	--------------------

- Mount screw **3** and tighten all screws in a crisscross pattern.

Guideline

Screw, water pump cover	M6x55	10 Nm (7.4 lbf ft)
-------------------------	-------	--------------------

16.5.19 Installing the suction pump

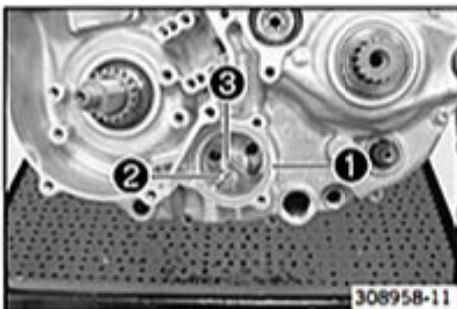

- Oil the internal rotor and external rotor before mounting.
- Insert O-ring **1**.
- Position pin **2** into the oil pump shaft from above.
- Position pin **3**.



- Mount internal rotor 4 and external rotor 5.
- ✓ The rounded sides of the external rotor face the engine case.

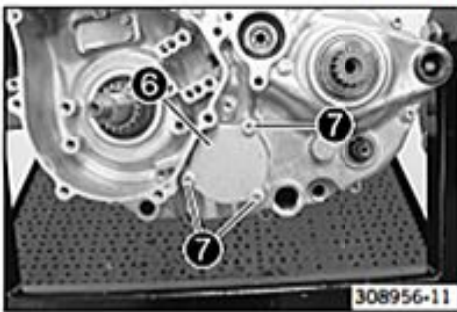

- Position oil pump cover 6. Mount and tighten screws 7.

Guideline

Screw, suction pump cover	M5	6 Nm (4.4 lbf ft)	Loctite® 243™
---------------------------	----	----------------------	---------------

16.5.20 Installing the ignition pulse generator



- Position the ignition pulse generator.

Info
Use the middle drill hole pair.

- Mount and tighten screws 1.

Guideline

Screw, crankshaft position sensor	M5	6 Nm (4.4 lbf ft)	Loctite® 243™
-----------------------------------	----	----------------------	---------------

- Position the cable and insert the cable sleeve into the engine case.

16.5.21 Installing the timing chain

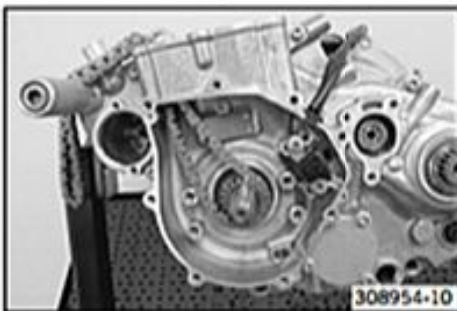

- Thread in the timing chain and place it over the timing chain sprocket.

Info
If the timing chain was used before, ensure it is running in the correct direction.



- Position the timing chain securing guide.
- Mount and tighten screws 1.

Guideline

Screw, timing chain securing guide	M6	10 Nm (7.4 lbf ft)	Loctite® 243™
------------------------------------	----	-----------------------	---------------

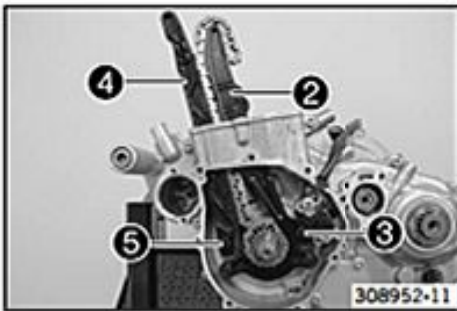

- Thread in the timing chain tensioning rail **2** from above.
- Mount and tighten screw **3**.

Guideline

Screw, timing chain tensioning rail	M6	10 Nm (7.4 lbf ft)	Loctite® 243™
-------------------------------------	----	-----------------------	---------------

- Slip in the timing chain guide rail **4** from above.
- Mount and tighten screw **5**.

Guideline

Screw, timing chain guide rail	M6	10 Nm (7.4 lbf ft)	Loctite® 243™
--------------------------------	----	-----------------------	---------------

16.5.22 Installing the rotor



- Mount the spring washer.
- Mount the rotor.
- Mount and tighten nut **1** with the spring washer.

Guideline

Nut, rotor	M12x1	60 Nm (44.3 lbf ft)	Thread, oiled with engine oil/cone degreased
------------	-------	------------------------	--

16.5.23 Installing the piston



- Move the joints of the compression ring and oil scraper ring so they are offset by 180°.
- Place the oiled piston on the cylinder.
- Compress the piston rings using the special tool.

Piston ring mounting tool (60029015000) (☛ p. 265)
--



- Tap lightly on the piston ring mounting tool from above with a plastic hammer so that it lies flush with the cylinder.
 - ✓ The special tool must press the piston rings together properly and lie flush with the cylinder.



- Carefully tap the piston into the cylinder using the handle of the hammer.
 - ✓ The piston rings should not catch or they will be damaged.



- Mount dowels ① and put cylinder base gasket ② in place.



- Ensure that piston mark ③ faces toward the exhaust side.



- Cover the engine housing opening with a cloth.
- Feed the timing chain through the timing chain shaft and mount the piston pin.

i Info

In order to present them more clearly, the following steps are shown with a removed piston.

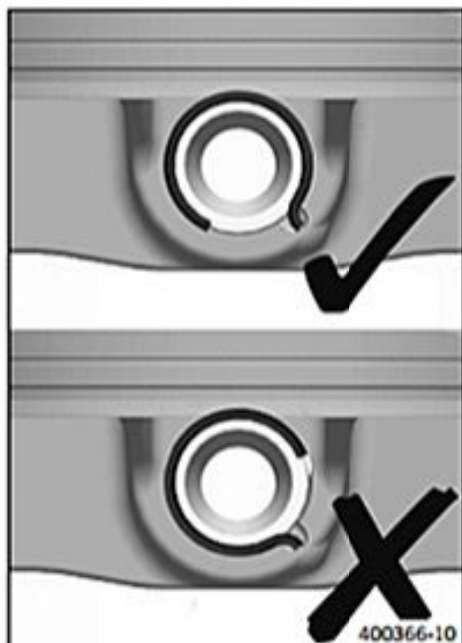

- Position the piston pin retainer.



200084-10

- Insert the special tool and press it forcefully to the piston.
- Turn the special tool counterclockwise, thereby pushing the piston pin retainer into the groove.

Insert for piston pin retainer (77329030100) (☛ p. 268)

- Ensure that the piston pin retainer is seated properly on both sides.



308947-11

- Remove the cloth. Keep the timing chain taut.
- Carefully push the cylinder downward, letting the dowels engage.

16.5.24 Installing the cylinder head



308946-11

- Mount dowels ① and put cylinder base gasket ② in place.

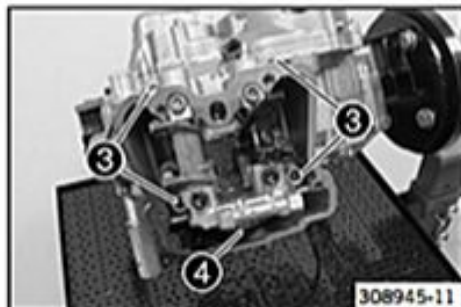

308945-11

- Put the cylinder head in place.
- Mount screws ③ with the washers and tighten them in a crisscross pattern.

Guideline

Screw, cylinder head	M10x1.25	Step 1	Lubricated with engine oil
		10 Nm (7.4 lbf ft)	
		Step 2	
		30 Nm (22.1 lbf ft)	
		Step 3	
		50 Nm (36.9 lbf ft)	

- Mount and tighten screw ④.

Guideline

Screw, cylinder head	M6	10 Nm (7.4 lbf ft)
----------------------	----	--------------------

16.5.25 Installing the camshaft

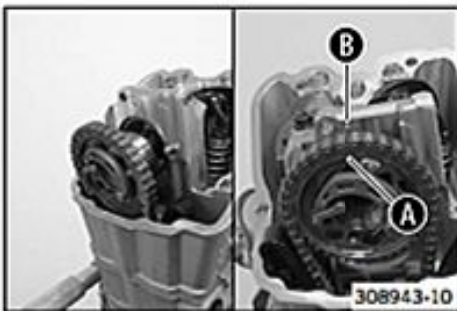

- Place the timing chain over the camshaft gear.
- Push the camshaft into the bearing seats.
- ✓ The camshaft **A** and cylinder head **B** markings are lined up with each other.

Info

Ensure that the crankshaft is at top dead center (TDC).

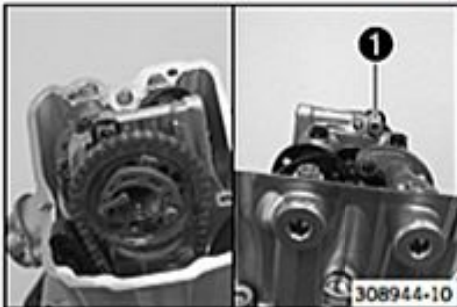

- Position the camshaft support plate.
- Mount and tighten screw **1**.

Guideline

Screw, camshaft support plate	M6	10 Nm (7.4 lbf ft)	Loctite® 243™
-------------------------------	----	--------------------	---------------

16.5.26 Installing the timing chain tensioner

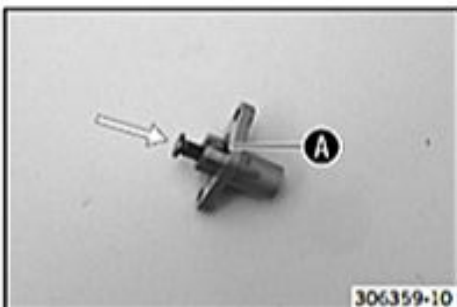

- Activate release **A** and push the timing chain tensioner all the way back.



- Position the timing chain tensioner with the gasket.
- Mount and tighten screws **1**.

Guideline

Screw, timing chain tensioner	M6	10 Nm (7.4 lbf ft)
-------------------------------	----	--------------------

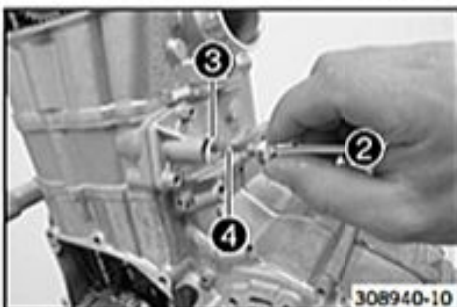

- Mount and tighten screw plug **2** with washer **3** and spring **4**.

Guideline

Plug, timing chain tensioner	M8	8 Nm (5.9 lbf ft)
------------------------------	----	-------------------

16.5.27 Checking the valve clearance

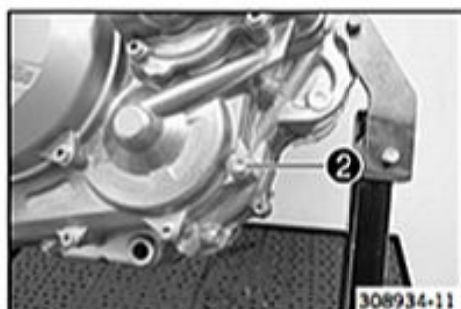

- Remove special tool ①.

Locking screw (113080802) (☞ p. 262)

- Crank over the engine repeatedly.
- Position the engine at ignition top dead center. (☞ p. 157)

- Check the valve clearance at all valves between the valve and rocker arm.

Guideline

Valve clearance	
Intake at: 20 °C (68 °F)	0.10... 0.15 mm (0.0039... 0.0059 in)
Exhaust at: 20 °C (68 °F)	0.12... 0.17 mm (0.0047... 0.0067 in)

Feeler gauge (59029041100) (☞ p. 265)

- If the valve clearance does not meet specifications:
 - Adjust the valve clearance. (☞ p. 217)

- Remove the special tool.

Locking screw (113080802) (☞ p. 262)

- Mount and tighten screw ②.

Guideline

Screw plug, crankshaft location	M8	10 Nm (7.4 lbf ft)
---------------------------------	----	--------------------

16.5.28 Adjusting the valve clearance

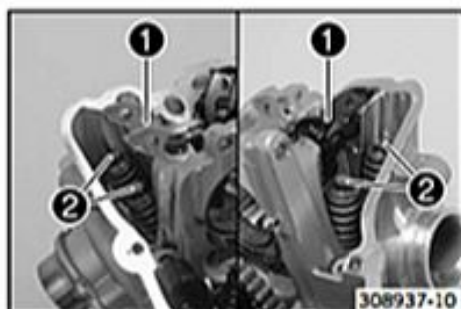

- Remove the timing chain tensioner. (☞ p. 158)
- Remove the camshaft. (☞ p. 158)
- Raise rocker arm ① on the outside.
- Remove shims ② and set down in the position in which they were installed.
- Correct the shims according to the findings from checking the valve clearance.
- Insert suitable shims.
- Install the camshaft. (☞ p. 216)
- Install the timing chain tensioner. (☞ p. 216)
- Check the valve clearance. (☞ p. 217)

16.5.29 Installing the alternator cover

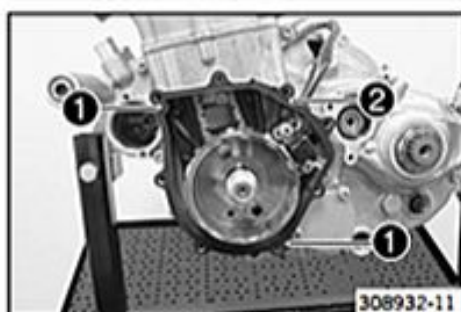

- Mount locating pins ①.
- Position alternator cover gasket ②.

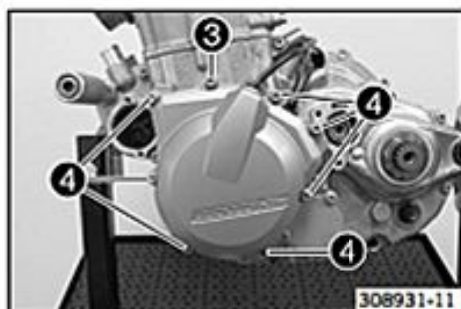

- Position the alternator cover.
- Mount screw ③ with washer but do not tighten it yet.

Guideline

Screw, alternator cover	M6x25	10 Nm (7.4 lbf ft)
-------------------------	-------	--------------------

- Mount screws ④ and tighten all screws in a crisscross pattern.

Guideline

Screw, alternator cover	M6x25	10 Nm (7.4 lbf ft)
-------------------------	-------	--------------------

16.5.30 Installing the valve cover



- Position the valve cover seal.
- Position the valve cover.
- Mount and tighten screws ①.

Guideline

Screw, valve cover	M6	10 Nm (7.4 lbf ft)
--------------------	----	--------------------

16.5.31 Installing the spark plug



- Mount and tighten the spark plug with the special tool.

Guideline

Spark plug	M12x1.25	15... 20 Nm (11.1... 14.8 lbf ft)
------------	----------	---

Spark plug wrench (75029172000) (☛ p. 268)		
--	--	--

16.5.32 Installing the starter motor



- Grease the O-ring.
- Mount the starter motor.

Long-life grease (☛ p. 260)

- Mount and tighten screws ①.

Guideline

Screw, starter motor	M6	10 Nm (7.4 lbf ft)
----------------------	----	--------------------

16.5.33 Installing the oil filter

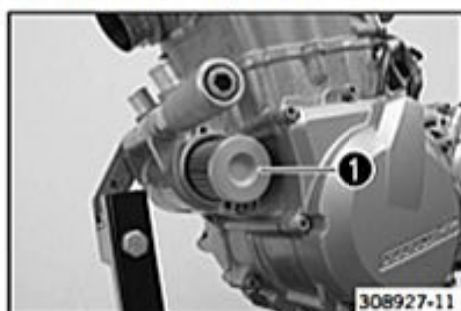

- Tilt the motorcycle to one side and fill the oil filter housing to about 1/3 full with engine oil.
- Insert oil filter ① into the oil filter housing.

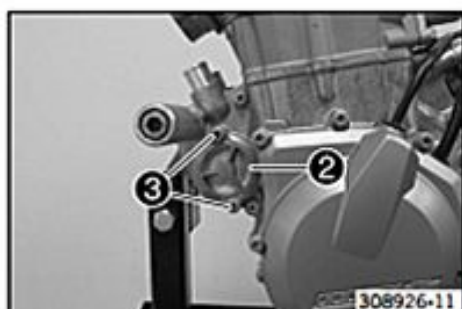

- Oil the O-ring of the oil filter cover.
- Mount oil filter cover ②.
- Mount and tighten screws ③.

Guideline

Screw, oil filter cover	M5	6 Nm (4.4 lbf ft)
-------------------------	----	-------------------

16.5.34 Installing the clutch push rod



- Mount clutch push rod ①.

16.5.35 Installing the oil screens



- Mount and tighten screw plug ① with the short oil screen and the O-ring.

Guideline

Screw plug, oil screen	M20x1.5	15 Nm (11.1 lbf ft)
------------------------	---------	------------------------

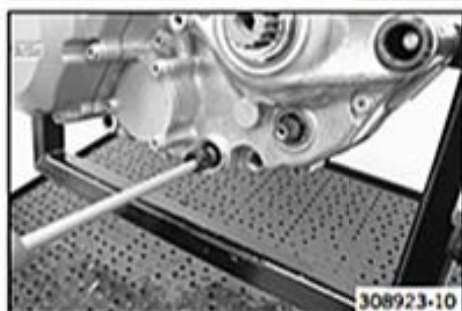

- Place the long oil screen with the O-rings onto a pin wrench.
- Push the pin wrench through the opening into the drill hole of the opposite engine case wall and push the oil screen as far as possible into the engine case.

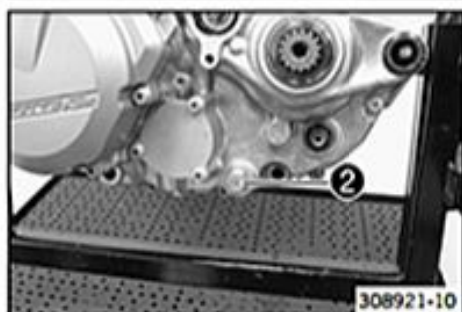

- Mount and tighten screw plug ② with the O-ring.

Guideline

Screw plug, oil screen	M20x1.5	15 Nm (11.1 lbf ft)
------------------------	---------	------------------------



- Mount and tighten the oil drain plug ③ with the magnet and the new seal ring.

Guideline

Oil drain plug with magnet	M12x1.5	20 Nm (14.8 lbf ft)
----------------------------	---------	------------------------

16.5.36 Removing the engine from the engine assembly stand



- Remove the screw connection from the special tool.

Engine bracket (78029002000) (☛ p. 268)

- Remove the engine from the engine assembly stand.

**Info**

Have an assistant help you or use a motorized hoist.

17.1 Checking/correcting the fluid level of the hydraulic clutch

- i** **Info**
The fluid level rises with increased wear of the clutch lining discs.

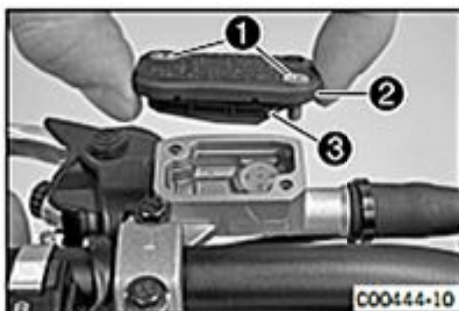

- Move the clutch fluid reservoir mounted on the handlebar to a horizontal position.
- Remove screws **1**.
- Remove cover **2** with membrane **3**.
- Check the fluid level.

Fluid level below container rim	4 mm (0.16 in)
---------------------------------	----------------

- If the fluid level does not meet specifications:
 - Correct the fluid level of the hydraulic clutch.

Brake fluid DOT 4 / DOT 5.1 (☞ p. 258)
--

- Position the cover with the membrane. Mount and tighten the screws.

17.2 Changing the hydraulic clutch fluid

- Warning**
Environmental hazard Hazardous substances cause environmental damage.

- Oil, grease, filters, fuel, cleaners, brake fluid, etc., should be disposed of as stipulated in applicable regulations.

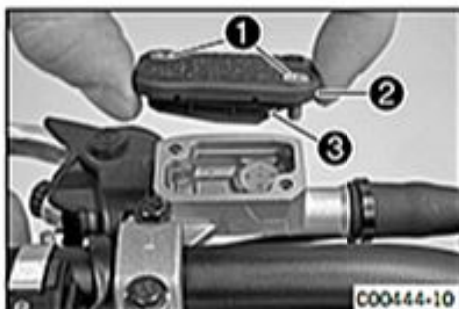

- Move the clutch fluid reservoir mounted on the handlebar to a horizontal position.
- Remove screws **1**.
- Remove cover **2** with membrane **3**.



- Fill bleeding syringe **4** with the appropriate hydraulic fluid.

Bleed syringe (50329050000) (☞ p. 263)
--

Brake fluid DOT 4 / DOT 5.1 (☞ p. 258)
--

- On the clutch slave cylinder, remove bleeder screw **5** and mount bleeding syringe **4**.

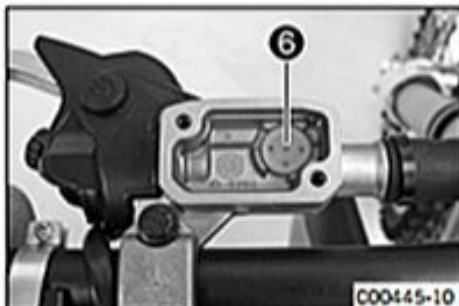

- Inject the liquid into the system until it escapes from hole **6** of the master cylinder without bubbles.
- To prevent overflow, drain fluid occasionally from the master cylinder reservoir.
- Remove the bleeding syringe. Mount and tighten screws bleeder screw.
- Correct the fluid level of the hydraulic clutch.

Guideline

Fluid level below container rim	4 mm (0.16 in)
---------------------------------	----------------

- Position the cover with the membrane. Mount and tighten the screws.

18.1 Cooling system



Water pump **1** in the engine circulates the coolant. The pressure resulting from the warming of the cooling system is regulated by a valve in radiator cap **2**. This ensures that operating the vehicle at the specified coolant temperature will not result in a risk of malfunctions.

120 °C (248 °F)

Cooling is effected by the air stream. The lower the speed, the less the cooling effect. Dirty cooling fins also reduce the cooling effect.

18.2 Checking the antifreeze and coolant level

**Warning**

Danger of scalding During motorcycle operation, the coolant gets very hot and is under pressure.

- Do not remove the radiator cap, radiator hoses or other cooling system components when the engine is hot. Allow the engine and cooling system to cool down. In case of scalding, rinse immediately with lukewarm water.

**Warning**

Danger of poisoning Coolant is poisonous and a health hazard.

- Coolant must not come into contact with the skin, eyes, or clothing. If contact occurs with the eyes, rinse with water immediately and contact a physician. Immediately clean contaminated areas on the skin with soap and water. If coolant is swallowed, contact a physician immediately. Change clothing that is contaminated with coolant. Keep coolant out of reach of children.

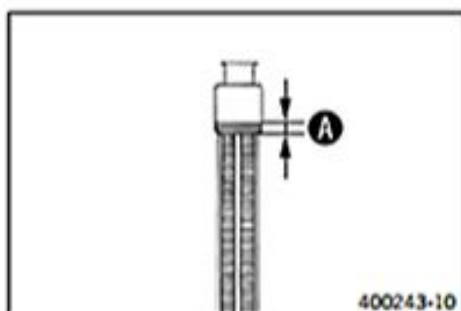
**Condition**

The engine is cold.

- Stand the motorcycle upright on a horizontal surface.
- Remove the radiator cap.
- Check antifreeze of coolant.

-25... -45 °C (-13... -49 °F)

- If the antifreeze of the coolant does not meet specifications:
 - Correct the antifreeze of the coolant.
- Check the coolant level in the radiator.

Coolant level **A** above radiator fins. 10 mm (0.39 in)

- If the coolant level does not meet specifications:
 - Correct the coolant level.

Alternative 1

Coolant (☞ p. 258)

Alternative 2

Coolant (mixed ready to use) (☞ p. 258)

- Mount the radiator cap.

18.3 Checking the coolant level

**Warning**

Danger of scalding During motorcycle operation, the coolant gets very hot and is under pressure.

- Do not remove the radiator cap, radiator hoses or other cooling system components when the engine is hot. Allow the engine and cooling system to cool down. In case of scalding, rinse immediately with lukewarm water.

**Warning**

Danger of poisoning Coolant is poisonous and a health hazard.

- Coolant must not come into contact with the skin, eyes, or clothing. If contact occurs with the eyes, rinse with water immediately and contact a physician. Immediately clean contaminated areas on the skin with soap and water. If coolant is swallowed, contact a physician immediately. Change clothing that is contaminated with coolant. Keep coolant out of reach of children.

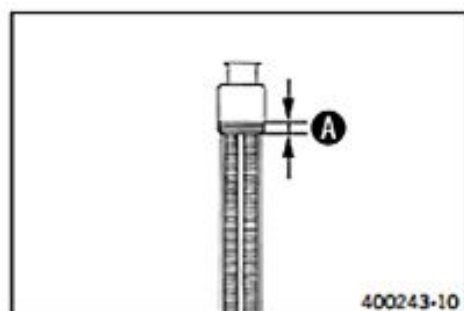
**Condition**

The engine is cold.

- Stand the motorcycle upright on a horizontal surface.
- Remove the radiator cap.
- Check the coolant level in the radiator.

Coolant level A above radiator fins.	10 mm (0.39 in)
---	-----------------

- If the coolant level does not meet specifications:
 - Correct the coolant level.

Alternative 1

Coolant (☞ p. 258)

Alternative 2

Coolant (mixed ready to use) (☞ p. 258)

- Mount the radiator cap.

18.4 Draining the coolant**Warning**

Danger of scalding During motorcycle operation, the coolant gets very hot and is under pressure.

- Do not remove the radiator cap, radiator hoses or other cooling system components when the engine is hot. Allow the engine and cooling system to cool down. In case of scalding, rinse immediately with lukewarm water.

**Warning**

Danger of poisoning Coolant is poisonous and a health hazard.

- Coolant must not come into contact with the skin, eyes, or clothing. If contact occurs with the eyes, rinse with water immediately and contact a physician. Immediately clean contaminated areas on the skin with soap and water. If coolant is swallowed, contact a physician immediately. Change clothing that is contaminated with coolant. Keep coolant out of reach of children.

Condition

The engine is cold.

- Position the motorcycle upright.
- Place a suitable container under the water pump cover.
- Remove screw **1**. Take off radiator cap **2**.
- Completely drain the coolant.
- Mount and tighten screw **1** with a new seal ring.

Guideline

Screw, water pump cover	M6	10 Nm (7.4 lbf ft)
-------------------------	----	--------------------



18.5 Refilling coolant

**Warning****Danger of poisoning** Coolant is poisonous and a health hazard.

- Coolant must not come into contact with the skin, eyes, or clothing. If contact occurs with the eyes, rinse with water immediately and contact a physician. Immediately clean contaminated areas on the skin with soap and water. If coolant is swallowed, contact a physician immediately. Change clothing that is contaminated with coolant. Keep coolant out of reach of children.

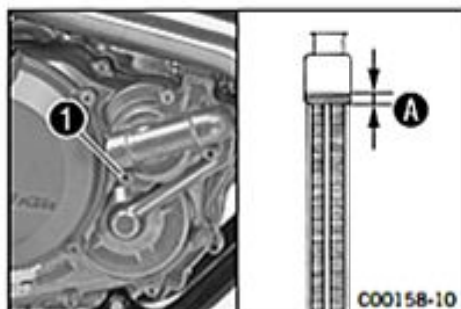

- Make sure that screw ① is tightened.
- Position the motorcycle upright.
- Pour coolant in up to measurement ① above the radiator fins.

Guideline

Dimension ① over the radiator fins	10 mm (0.39 in)	
Coolant	1.20 l (1.27 qt.)	Coolant (☛ p. 258)
		Coolant (mixed ready to use) (☛ p. 258)

- Mount the radiator cap.
- Take a short test ride.
- Check the coolant level. (☛ p. 222)

19.1 Oil circuit

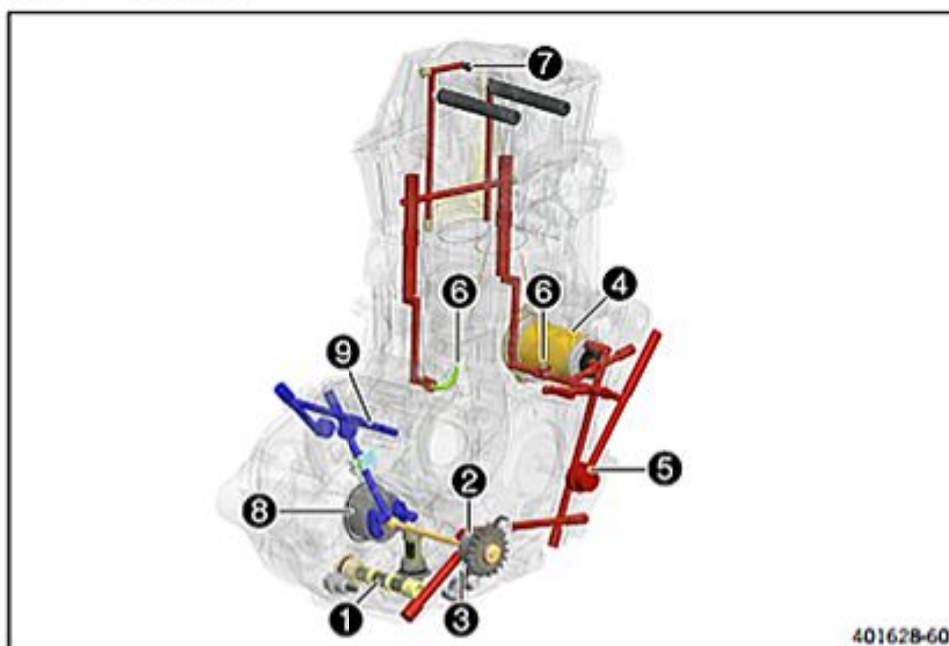

1	Oil screen
2	Force pump
3	Oil pressure regulator valve
4	Oil filter
5	Oil nozzle for conrod bearing lubrication
6	Oil nozzle, piston cooling
7	Oil nozzle for cam follower lubrication
8	Suction pump
9	Oil channel, transmission lubrication

19.2 Checking the engine oil level

Condition

The engine is at operating temperature.

Preparatory work

- Stand the motorcycle upright on a horizontal surface.

Main work

- Check the engine oil level.



Info

After switching off the engine, wait one minute before checking the level.

The engine oil level is between **A** and **B**.

- If the engine oil level is below marking **A**:
 - Add engine oil. (☛ p. 228)
- If the engine oil level is at marking **B** or above:
 - Correct the engine oil level.



19.3 Changing the engine oil and oil filter, cleaning the oil screens

Warning

Danger of scalding Engine oil and gear oil get very hot when the motorcycle is ridden.

- Wear appropriate protective clothing and safety gloves. In case of burns, rinse immediately with lukewarm water.



Warning

Environmental hazard Hazardous substances cause environmental damage.

- Oil, grease, filters, fuel, cleaners, brake fluid, etc., should be disposed of as stipulated in applicable regulations.

Info

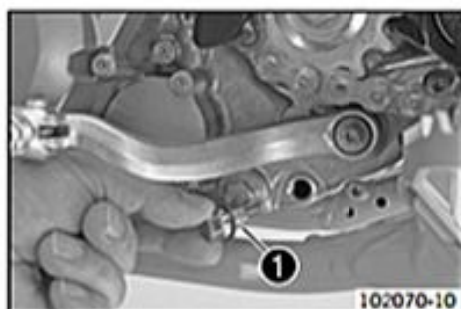
Drain the engine oil only when the engine is warm.

Preparatory work

- Park the motorcycle on a level surface.

Main work

- Place a suitable container under the engine.
- Remove oil drain plug 1 with the magnet and seal ring.

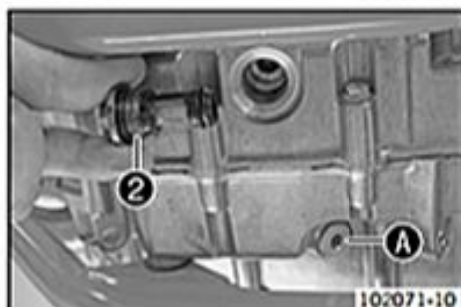

- Remove screw plug 2 with the short oil screen and the O-rings.

Info

Do not remove screw A.

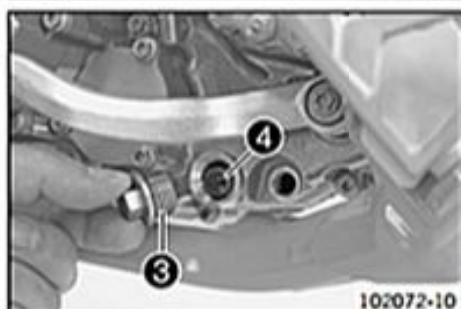

- Remove screw plug 3 with the long oil screen 4 and the O-rings.
- Completely drain the engine oil.
- Thoroughly clean the parts and sealing surfaces.

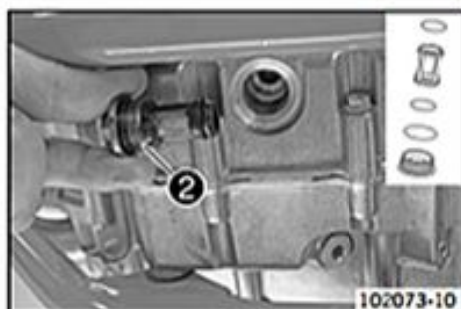

- Mount and tighten screw plug 2 with the short oil screen and the O-rings.

Guideline

Screw plug, oil screen	M20x1.5	15 Nm (11.1 lbf ft)
------------------------	---------	------------------------



102074-10

- Position oil screen **4** with the O-rings on a pin wrench.
- Position the pin wrench through the drilled hole of the screw plug in the opposite section of the engine case.
- Push the oil screen all the way into the engine case.

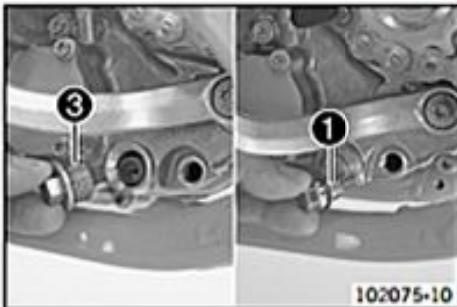

102075-10

- Mount and tighten screw plug **3** with the O-ring.

Guideline

Screw plug, oil screen	M20x1.5	15 Nm (11.1 lbf ft)
------------------------	---------	------------------------

- Mount and tighten the oil drain plug **1** with the magnet and a new seal ring.

Guideline

Oil drain plug with magnet	M12x1.5	20 Nm (14.8 lbf ft)
----------------------------	---------	------------------------

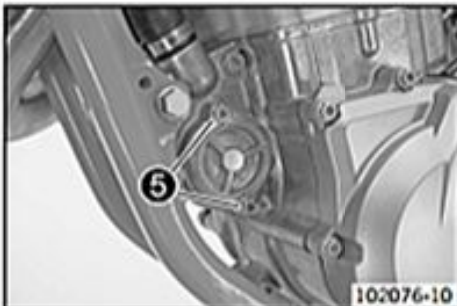

102076-10

- Remove screws **5**. Remove the oil filter cover with the O-ring.

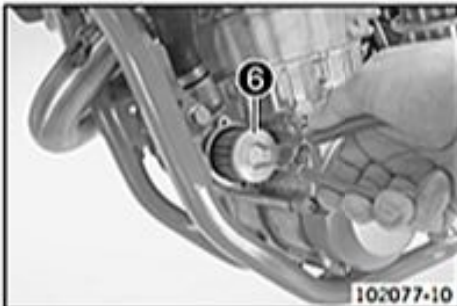

102077-10

- Pull oil filter **6** out of the oil filter housing.

Circclip pliers reverse (51012011000) (☞ p. 263)
--

- Completely drain the engine oil.
- Thoroughly clean the parts and sealing area.



102078-10

- Lay the motorcycle on its side and fill the oil filter housing to about 1/3 full with engine oil.
- Insert the oil filter into the oil filter housing.
- Lubricate the O-ring of the oil filter cover and mount it with the oil filter cover **7**.
- Mount and tighten the screws.

Guideline

Screw, oil filter cover	M5	6 Nm (4.4 lbf ft)
-------------------------	----	-------------------

- Stand the motorcycle upright.



601828-10

- Remove the oil filler plug **8** with the O-ring from the clutch cover and fill up with engine oil.

Engine oil	1.50 l (1.59 qt.)	Engine oil (SAE 10W/50) (☞ p. 258)
------------	-------------------	------------------------------------

Info

Too little engine oil or poor-quality engine oil results in premature wear to the engine.

- Install and tighten the oil filler plug with O-ring.



Danger

Danger of poisoning Exhaust gases are toxic and inhaling them may result in unconsciousness and/or death.

- When running the engine, always make sure there is sufficient ventilation, and do not start or run the engine in an enclosed space without an effective exhaust extraction system.

- Start the engine and check that it is oil-tight.

Finishing work

- Check the engine oil level. (☛ p. 225)

19.4 Adding engine oil



Info

Too little engine oil or poor-quality engine oil results in premature wear to the engine.



- Remove the oil filler plug ① with the O-ring from the clutch cover.
- Add the same engine oil that was used when the motor was changed.

Engine oil (SAE 10W/50) (☛ p. 258)



Info

For optimal performance of the engine oil, do not mix different types of engine oil.
If appropriate, change the engine oil.

- Install and tighten the oil filler plug with O-ring.



Danger

Danger of poisoning Exhaust gases are toxic and inhaling them may result in unconsciousness and/or death.

- When running the engine, always make sure there is sufficient ventilation, and do not start or run the engine in an enclosed space without an effective exhaust extraction system.

- Start the engine and check that it is oil-tight.

19.5 Checking the engine oil pressure



Main work

- Place a suitable container under the engine.
- Remove screws ①. Remove the oil filter cover with the O-ring.
- Remove the oil filter.

Circclip pliers reverse (51012011000) (☛ p. 263)



- Position special tool ② with the O-ring. Mount and tighten the screws.

Guideline

Screw, oil filter cover	M5	6 Nm (4.4 lbf ft)
-------------------------	----	-------------------

Oil pressure adapter (75029094000) (☛ p. 268)

- Connect the pressure tester without the t-plate to the special tool.

Pressure testing tool (61029094000) (☛ p. 266)

- Check the engine oil level. (☛ p. 225)



Danger

Danger of poisoning Exhaust gases are toxic and inhaling them may result in unconsciousness and/or death.

- When running the engine, always make sure there is sufficient ventilation, and do not start or run the engine in an enclosed space without an effective exhaust extraction system.

- Start the engine and let it warm up.
- Check the engine oil pressure.

Engine oil pressure	
Engine oil temperature: 80 °C (176 °F) Engine speed: 1,600 rpm	0.9 bar (13 psi)
Engine oil temperature: 80 °C (176 °F) Engine speed: 6,000 rpm	2.5 bar (36 psi)

- If the measured value is less than the specification:
 - Check the oil pump for wear. Check all oil channels for free flow.
- Switch off the engine.



Warning

Danger of burns Some vehicle components get very hot when the machine is driven.

- Wear appropriate protective clothing and safety gloves. In case of burns, rinse immediately with lukewarm water.

- Remove the special tools.
- Grease the O-ring of the oil filter cover. Mount the oil filter cover.
- Mount and tighten the screws.

Guideline

Screw, oil filter cover	M5	6 Nm (4.4 lbf ft)
-------------------------	----	-------------------

Finishing work

- Check the engine oil level. (☛ p. 225)

20.1 Ignition coil - checking the secondary winding

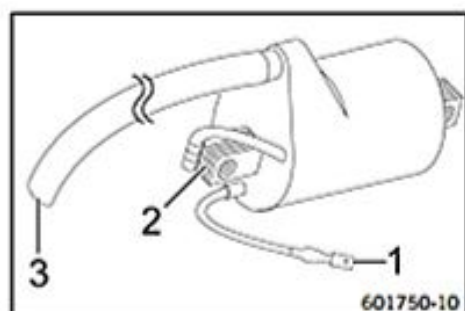
**Condition**

Ignition coil cylinder 1 is disconnected.

Spark plug connector cylinder 1 has been removed.

Ignition coil cylinder 1 - check the secondary winding resistance

- Ω Measure the resistance between the specified points.
Ignition coil cylinder 1 pin 2 (-) – Ignition coil cylinder 1 pin 3

Ignition coil	
Secondary winding resistance at: 20 °C (68 °F)	11.075... 15.525 k Ω

- If the displayed value does not correspond to specifications:
 - Change the ignition coil.

20.2 Checking the spark plug connector

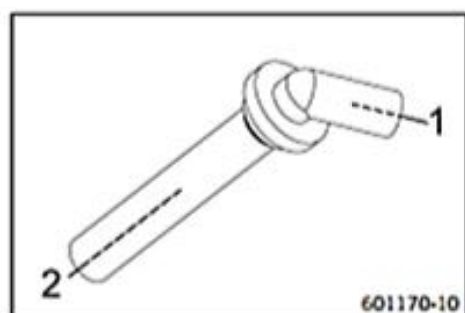
**Condition**

Spark plug connector cylinder 1 has been removed.

- Ω Measure the resistance between the specified points.
Measuring point 1 – Measuring point 2

Spark plug connector	
Resistance at: 20 °C (68 °F)	3.75... 6.25 k Ω

- If the specification is not reached:
 - Change the spark plug connector.

20.3 Alternator - checking stator winding

Condition

The alternator is disconnected.

**Stator winding - checking the resistance**

- Ω Measure the resistance between the specified points.
Alternator, connector CR pin 1 – Alternator, connector CR pin 1

Alternator	
Resistance of stator winding at: 20 °C (68 °F)	1.19... 1.61 Ω

- If the displayed value does meet specifications:
 - Change the stator.

**Stator winding - check the short circuit to ground (terminal 31)**

- Ω Measure the resistance between the specified points.
Alternator, connector CR pin 1 – Measuring point Ground (-)

Resistance	$\infty \Omega$
------------	-----------------

- If the displayed value does meet specifications:
 - Change the stator.

20.4 Removing the stator

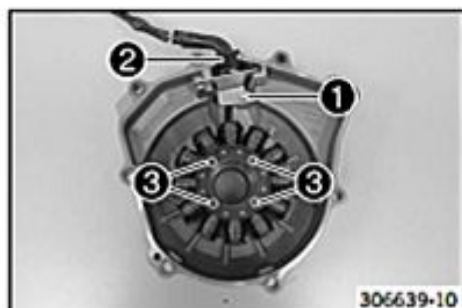
**Condition**

The alternator cover has been removed.

- Remove screw ① and take off the cable holder.
- Remove cable support sleeve ② from the alternator case.
- Remove screws ③.
- Take the stator out of the alternator cover.

20.5 Installing the stator

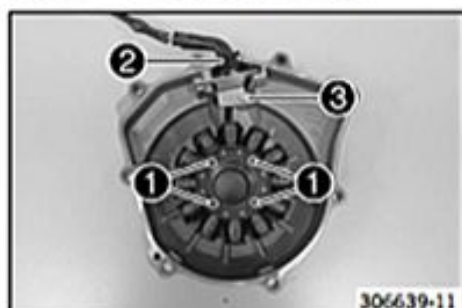

- Position the stator in the alternator cover.
- Mount and tighten screws ①.

Guideline

Screw, stator	M4	4 Nm (3 lbf ft)	Loctite® 648™
---------------	----	--------------------	---------------

- Position cable support sleeve ② in the alternator case.
- Position the cable holder. Mount and tighten screw ③.

Guideline

Screw, cable holder in alternator cover	M4	4 Nm (3 lbf ft)	Loctite® 243™
---	----	--------------------	---------------

21.1 Checking the starter motor



Condition

The starter motor has been removed.

- Connect the negative cable of a 12 volt power supply to the housing of the starter motor. Connect the positive cable of the power supply briefly with connector **1** of the starter motor.
 - If the starter motor does not turn when the circuit is closed:
 - Change the starter motor.

22.1 Adjusting the idle speed

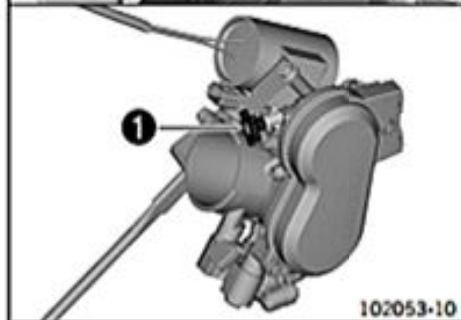

- Run the engine until warm.
- Set the desired idle speed by turning the idle speed adjusting screw ①.

Guideline

Idle speed	2,250... 2,350 rpm
Tachometer (45129075000) (☛ p. 263)	



Info

- Turn counterclockwise to decrease the idle speed.
- Turn clockwise to increase the idle speed.

22.2 Executing the initialization run

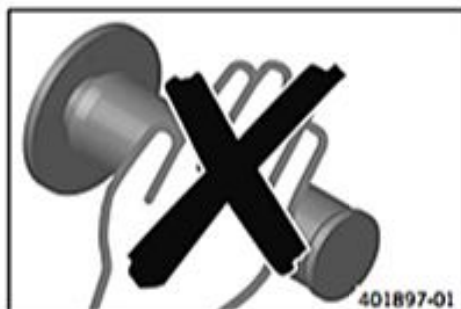

Condition

The diagnostic tool is connected and running.

- Execute "Engine electronics" > "Functions" > "Deleting adaptation values".
 - ✓ The adaptation values are deleted.
- Select "Engine electronics" > "Measured values" > "Engine coolant temperature sensor (TW1)".
 - ✓ The coolant temperature is displayed during the initialization run.



Danger

Danger of poisoning Exhaust gases are toxic and inhaling them may result in unconsciousness and/or death.

- When running the engine, always make sure there is sufficient ventilation, and do not start or run the engine in an enclosed space without an effective exhaust extraction system.

- Start the engine without operating the throttle grip.

Guideline

Coolant temperature	< 25 °C (< 77 °F)
---------------------	-------------------

- Let the engine idle until it reaches the specified temperature.

Guideline

Coolant temperature	80... 90 °C (176... 194 °F)
---------------------	-----------------------------



Info

- Do not operate the throttle grip during the initialization process.

- As soon as the specified temperature is reached, switch off the ignition.



Info

- If the initialization is not completed or the initialization process is interrupted, the entire process must be restarted.

23.1 Engine

Design	1-cylinder 4-stroke engine, water-cooled
Displacement	449.3 cm ³ (27.418 cu in)
Stroke	63.4 mm (2.496 in)
Bore	95 mm (3.74 in)
Compression ratio	12.6:1
Idle speed	2,250... 2,350 rpm
Control	OHC, 4 valves controlled via rocker arm
Valve diameter, intake	40 mm (1.57 in)
Valve diameter, exhaust	33 mm (1.3 in)
Valve clearance	
Intake at: 20 °C (68 °F)	0.10... 0.15 mm (0.0039... 0.0059 in)
Exhaust at: 20 °C (68 °F)	0.12... 0.17 mm (0.0047... 0.0067 in)
Crankshaft bearing	2 grooved ball bearings
Conrod bearing	Slide bearing
Piston pin bearing	Not a bearing bush - DLC-plated piston pins
Pistons	Forged light alloy
Piston rings	1 compression ring, 1 oil scraper ring
Engine lubrication	Pressure circulation lubrication with two Eaton pumps
Primary transmission	32:76
Clutch	Multidisc clutch in oil bath/hydraulically activated
Gearbox (SX-F EU)	4-gear, claw shifted
Gearbox (SX-F USA, XC-F)	5-gear, claw shifted
Transmission ratio (SX-F EU)	
1st gear	16:32
2nd gear	18:30
3rd gear	20:28
4th gear	22:26
Transmission ratio (SX-F USA, XC-F)	
1st gear	16:32
2nd gear	18:30
3rd gear	20:28
4th gear	22:26
5th gear	24:24
Alternator	12 V, 75 W
Ignition	Contactless controlled fully electronic ignition with digital ignition adjustment
Spark plug	NGK LKAR8AI-9
Spark plug electrode gap	0.9 mm (0.035 in)
Cooling	Water cooling, permanent circulation of coolant by water pump
Starting aid	Electric starter

23.2 Engine tolerance, wear limits

Camshaft - cam height	
Exhaust	33.10... 33.30 mm (1.3031... 1.311 in)
Intake	33.90... 34.10 mm (1.3346... 1.3425 in)
Valve spring	
Intake minimum length (without valve spring seat)	40.7 mm (1.602 in)
Exhaust minimum length (without valve spring seat)	40.7 mm (1.602 in)
Valve spring seat	1.8 mm (0.071 in)
Cylinder/cylinder head - sealing area distortion	≤ 0.1 mm (≤ 0.004 in)
Piston - diameter	

Size I	94.93... 94.96 mm (3.7374... 3.7386 in)
Size II	94.94... 94.97 mm (3.7378... 3.739 in)
Cylinder - drill hole diameter	
Size I	95... 95.012 mm (3.74... 3.74062 in)
Size II	95.013... 95.025 mm (3.74066... 3.74113 in)
Piston/cylinder - mounting clearance	
Size I	0.040... 0.082 mm (0.00157... 0.00323 in)
Size II	0.043... 0.085 mm (0.00169... 0.00335 in)
Wear limit	0.120 mm (0.00472 in)
Piston ring end gap	
Compression ring	≤ 1 mm (≤ 0.04 in)
Oil scraper ring	≤ 1.2 mm (≤ 0.047 in)
Connecting rod - end play of lower conrod bearing	0.20... 0.45 mm (0.0079... 0.0177 in)
Crankshaft - run-out on bearing pin	≤ 0.04 mm (≤ 0.0016 in)
Clutch facing disc - thickness	≥ 1.9 mm (≥ 0.075 in)
Thrust surface, clutch facing discs in outer clutch hub	≤ 0.5 mm (≤ 0.02 in)
Oil pressure regulator valve	
Minimum length of preload spring	24.5 mm (0.965 in)
Shift shaft - play in sliding plate/shift quadrant	0.4... 0.8 mm (0.016... 0.031 in)

23.3 Engine tightening torques

Screw, membrane	M3	1.5 Nm (1.11 lbf ft)	Loctite® 243™
Screw, cable holder in alternator cover	M4	4 Nm (3 lbf ft)	Loctite® 243™
Screw, oil jet for piston cooling	M4	2 Nm (1.5 lbf ft)	Loctite® 243™
Screw, stator	M4	4 Nm (3 lbf ft)	Loctite® 648™
Oil nozzle, piston cooling	M5	2 Nm (1.5 lbf ft)	Loctite® 243™
Oil nozzle, rocker arm lubrication	M5	2 Nm (1.5 lbf ft)	Loctite® 243™
Screw, bearing retainer	M5	6 Nm (4.4 lbf ft)	Loctite® 2701™
Screw, clutch spring retainer	M5	6 Nm (4.4 lbf ft)	-
Screw, crankshaft position sensor	M5	6 Nm (4.4 lbf ft)	Loctite® 243™
Screw, locking lever	M5	6 Nm (4.4 lbf ft)	Loctite® 243™
Screw, oil filter cover	M5	6 Nm (4.4 lbf ft)	-
Screw, suction pump cover	M5	6 Nm (4.4 lbf ft)	Loctite® 243™
Nut, water-pump wheel	M6	8 Nm (5.9 lbf ft)	Loctite® 243™
Screw, alternator cover	M6	10 Nm (7.4 lbf ft)	-
Screw, bearing bolt for starter idler gear	M6	10 Nm (7.4 lbf ft)	Loctite® 243™
Screw, bearing bolt, torque limiter	M6	10 Nm (7.4 lbf ft)	Loctite® 243™
Screw, camshaft support plate	M6	10 Nm (7.4 lbf ft)	Loctite® 243™
Screw, clutch cover	M6	10 Nm (7.4 lbf ft)	-
Screw, cylinder head	M6	10 Nm (7.4 lbf ft)	-
Screw, engine case	M6	10 Nm (7.4 lbf ft)	-
Screw, exhaust flange	M6	10 Nm (7.4 lbf ft)	Loctite® 243™
Screw, pressure pump cover	M6	10 Nm (7.4 lbf ft)	Loctite® 243™
Screw, shift drum locating	M6	10 Nm (7.4 lbf ft)	Loctite® 243™
Screw, shift lever	M6	14 Nm (10.3 lbf ft)	Loctite® 243™
Screw, starter motor	M6	10 Nm (7.4 lbf ft)	-
Screw, timing chain guide rail	M6	10 Nm (7.4 lbf ft)	Loctite® 243™
Screw, timing chain securing guide	M6	10 Nm (7.4 lbf ft)	Loctite® 243™
Screw, timing chain tensioner	M6	10 Nm (7.4 lbf ft)	-
Screw, timing chain tensioning rail	M6	10 Nm (7.4 lbf ft)	Loctite® 243™
Screw, valve cover	M6	10 Nm (7.4 lbf ft)	-

Screw, water pump cover	M6	10 Nm (7.4 lbf ft)	–
Oil nozzle for conrod bearing lubrication	M6x0.75	4 Nm (3 lbf ft)	–
Plug, oil channel	M7	9 Nm (6.6 lbf ft)	Loctite® 243™
Screw, rocker arm bearing	M7	15 Nm (11.1 lbf ft)	–
Plug, timing chain tensioner	M8	8 Nm (5.9 lbf ft)	–
Screw plug, crankshaft location	M8	10 Nm (7.4 lbf ft)	–
Plug, oil channel	M10	15 Nm (11.1 lbf ft)	Loctite® 243™
Screw, engine sprocket	M10	60 Nm (44.3 lbf ft)	Loctite® 2701™
Screw, cylinder head	M10x1.25	Step 1 10 Nm (7.4 lbf ft) Step 2 30 Nm (22.1 lbf ft) Step 3 50 Nm (36.9 lbf ft)	Lubricated with engine oil
Nut, rotor	M12x1	60 Nm (44.3 lbf ft)	Thread, oiled with engine oil/cone degreased
Spark plug	M12x1.25	15... 20 Nm (11.1... 14.8 lbf ft)	–
Engine coolant temperature sensor	M12x1.5	12 Nm (8.9 lbf ft)	–
Oil drain plug with magnet	M12x1.5	20 Nm (14.8 lbf ft)	–
Plug, oil pressure regulator valve	M12x1.5	20 Nm (14.8 lbf ft)	–
Nut, inner clutch hub	M18x1.5	80 Nm (59 lbf ft)	–
Screw plug, rocker arm	M18x1.5	30 Nm (22.1 lbf ft)	–
Nut, primary gear	M20LHx1.5	100 Nm (73.8 lbf ft)	Loctite® 648™
Screw plug, oil screen	M20x1.5	15 Nm (11.1 lbf ft)	–

23.4 Capacities

23.4.1 Engine oil

Engine oil	1.50 l (1.59 qt.)	Engine oil (SAE 10W/50) (☛ p. 258)
------------	-------------------	------------------------------------

23.4.2 Coolant

Coolant	1.20 l (1.27 qt.)	Coolant (☛ p. 258)
		Coolant (mixed ready to use) (☛ p. 258)

23.4.3 Fuel

Total fuel tank capacity, approx. (SX-F EU, SX-F USA)	7.5 l (1.98 US gal)	Super unleaded (ROZ 95/RON 95/PON 91) (☛ p. 259)
Total fuel tank capacity, approx. (XC-F)	9 l (2.4 US gal)	Super unleaded (ROZ 95/RON 95/PON 91) (☛ p. 259)

Fuel reserve, approx. (XC-F)	1.5 l (1.6 qt.)
------------------------------	-----------------

23.5 Chassis

Frame	Central tube frame made of chrome molybdenum steel tubing
Fork (SX-F EU)	WP Suspension Up Side Down 4860 MXMA CC
Fork (SX-F USA, XC-F)	WP Suspension Up Side Down 4860 MXMA 4CS
Suspension travel	
Front	300 mm (11.81 in)
Suspension travel	
Rear	317 mm (12.48 in)
Fork offset	22 mm (0.87 in)
Shock absorber	WP Suspension 5018 BAVP DCC

Brake system	Disc brakes, brake calipers on floating bearings
Brake discs - diameter	
Front	260 mm (10.24 in)
Rear	220 mm (8.66 in)
Brake discs - wear limit	
Front	2.5 mm (0.098 in)
Rear	3.5 mm (0.138 in)
Tire air pressure off road	
Front	1.0 bar (15 psi)
Rear	1.0 bar (15 psi)
Secondary ratio (SX-F EU)	14:50
Secondary ratio (SX-F USA, XC-F)	14:52
Chain	5/8 x 1/4"
Rear sprockets available	38, 40, 42, 45, 48, 49, 50, 51, 52
Steering head angle	63.5°
Wheelbase	1,495±10 mm (58.86±0.39 in)
Seat height, unloaded	992 mm (39.06 in)
Ground clearance, unloaded	371 mm (14.61 in)
Weight without fuel, approx. (SX-F EU)	105.5 kg (232.6 lb.)
Weight without fuel, approx. (SX-F USA)	106.8 kg (235.5 lb.)
Weight without fuel, approx. (XC-F)	108.5 kg (239.2 lb.)
Maximum permissible front axle load	145 kg (320 lb.)
Maximum permissible rear axle load	190 kg (419 lb.)
Maximum permissible overall weight	335 kg (739 lb.)

23.6 Electrical system

Battery (SX-F EU, SX-F USA)	YTX4L-BS	Battery voltage: 12 V Nominal capacity: 3 Ah Maintenance-free
Battery (XC-F)	YTX5L-BS	Battery voltage: 12 V Nominal capacity: 4 Ah Maintenance-free
Fuse	58011109110	10 A
FI warning lamp	LED	
Remaining indicator lamps (XC-F)	W2.3W/socket W2x4.6d	12 V 2.3 W

23.7 Tires

Validity	Front tires	Rear tires
(SX-F EU, SX-F USA)	80/100 - 21 M/C 51M TT Dunlop GEOMAX MX 52 F	110/90 - 19 62M TT Dunlop GEOMAX MX 52
(XC-F)	90/90 - 21 54M TT Dunlop GEOMAX AT81F	110/100 - 18 64M TT Dunlop GEOMAX AT81

Additional information is available in the Service section under:
<http://www.ktm.com>

23.8 Fork**23.8.1 SX-F EU**

Fork part number	14.18.70.09	
Fork	WP Suspension Up Side Down 4860 MXMA CC	
Compression damping		
Comfort	14 clicks	
Standard	12 clicks	
Sport	10 clicks	
Rebound damping		
Comfort	14 clicks	
Standard	12 clicks	
Sport	10 clicks	
Spring length with preload spacer(s)	490 mm (19.29 in)	
Spring rate		
Weight of rider: 65... 75 kg (143... 165 lb.)	4.6 N/mm (26.3 lb/in)	
Weight of rider: 75... 85 kg (165... 187 lb.)	4.8 N/mm (27.4 lb/in)	
Weight of rider: 85... 95 kg (187... 209 lb.)	5.0 N/mm (28.6 lb/in)	
Gas pressure	1.2 bar (17 psi)	
Fork length	940 mm (37.01 in)	
Oil capacity per cartridge	195 ml (6.59 fl. oz.)	Fork oil (SAE 4) (48601166S1) (☛ p. 258)
Oil capacity fork leg without cartridge	400 ml (13.52 fl. oz.)	Fork oil (SAE 4) (48601166S1) (☛ p. 258)

23.8.2 SX-F USA

Fork part number	24.18.70.57	
Fork	WP Suspension Up Side Down 4860 MXMA 4CS	
Compression damping		
Comfort	17 clicks	
Standard	15 clicks	
Sport	13 clicks	
Rebound damping		
Comfort	17 clicks	
Standard	15 clicks	
Sport	13 clicks	
Spring length with preload spacer(s)	480 mm (18.9 in)	
Spring rate		
Weight of rider: 65... 75 kg (143... 165 lb.)	4.6 N/mm (26.3 lb/in)	
Weight of rider: 75... 85 kg (165... 187 lb.)	4.8 N/mm (27.4 lb/in)	
Weight of rider: 85... 95 kg (187... 209 lb.)	5.0 N/mm (28.6 lb/in)	
Fork length	940 mm (37.01 in)	
Oil capacity per fork leg	665 ml (22.48 fl. oz.)	Fork oil (SAE 4) (48601166S1) (☛ p. 258)

23.8.3 XC-F

Fork part number	24.18.70.79	
Fork	WP Suspension Up Side Down 4860 MXMA 4CS	
Compression damping		
Comfort	17 clicks	
Standard	15 clicks	
Sport	13 clicks	
Rebound damping		

Comfort	17 clicks	
Standard	15 clicks	
Sport	13 clicks	
Spring length with preload spacer(s)	480 mm (18.9 in)	
Spring rate		
Weight of rider: 65... 75 kg (143... 165 lb.)	4.4 N/mm (25.1 lb/in)	
Weight of rider: 75... 85 kg (165... 187 lb.)	4.6 N/mm (26.3 lb/in)	
Weight of rider: 85... 95 kg (187... 209 lb.)	4.8 N/mm (27.4 lb/in)	
Fork length	940 mm (37.01 in)	
Oil capacity per fork leg	680 ml (22.99 fl. oz.)	Fork oil (SAE 4) (48601166S1) (☛ p. 258)

23.9 Shock absorber

23.9.1 SX-F EU

Shock absorber part number	18.18.70.09	
Shock absorber	WP Suspension 5018 BAVP DCC	
Compression damping, low-speed		
Comfort	17 clicks	
Standard	15 clicks	
Sport	13 clicks	
Compression damping, high-speed		
Comfort	2.5 turns	
Standard	2 turns	
Sport	1.5 turns	
Rebound damping		
Comfort	17 clicks	
Standard	15 clicks	
Sport	13 clicks	
Spring preload	8 mm (0.31 in)	
Spring rate		
Weight of rider: 65... 75 kg (143... 165 lb.)	54 N/mm (308 lb/in)	
Weight of rider: 75... 85 kg (165... 187 lb.)	57 N/mm (325 lb/in)	
Weight of rider: 85... 95 kg (187... 209 lb.)	60 N/mm (343 lb/in)	
Spring length	260 mm (10.24 in)	
Gas pressure	10 bar (145 psi)	
Static sag	30 mm (1.18 in)	
Riding sag	100 mm (3.94 in)	
Fitted length	490 mm (19.29 in)	
Shock absorber oil	Shock absorber fluid (SAE 2.5) (50180751S1) (☛ p. 258)	

23.9.2 SX-F USA

Shock absorber part number	18.18.70.59	
Shock absorber	WP Suspension 5018 BAVP DCC	
Compression damping, low-speed		
Comfort	17 clicks	
Standard	15 clicks	
Sport	13 clicks	
Compression damping, high-speed		
Comfort	2.5 turns	
Standard	2 turns	
Sport	1.5 turns	

Rebound damping	
Comfort	17 clicks
Standard	15 clicks
Sport	13 clicks
Spring preload	8 mm (0.31 in)
Spring rate	
Weight of rider: 65... 75 kg (143... 165 lb.)	54 N/mm (308 lb/in)
Weight of rider: 75... 85 kg (165... 187 lb.)	57 N/mm (325 lb/in)
Weight of rider: 85... 95 kg (187... 209 lb.)	60 N/mm (343 lb/in)
Spring length	260 mm (10.24 in)
Gas pressure	10 bar (145 psi)
Static sag	30 mm (1.18 in)
Riding sag	100 mm (3.94 in)
Fitted length	490 mm (19.29 in)
Shock absorber oil	Shock absorber fluid (SAE 2.5) (50180751S1) (☛ p. 258)

23.9.3 XC-F

Shock absorber part number	18.18.70.79
Shock absorber	WP Suspension 5018 BAVP DCC
Compression damping, low-speed	
Comfort	17 clicks
Standard	15 clicks
Sport	13 clicks
Compression damping, high-speed	
Comfort	2.5 turns
Standard	2 turns
Sport	1.5 turns
Rebound damping	
Comfort	17 clicks
Standard	15 clicks
Sport	13 clicks
Spring preload	8 mm (0.31 in)
Spring rate	
Weight of rider: 65... 75 kg (143... 165 lb.)	54 N/mm (308 lb/in)
Weight of rider: 75... 85 kg (165... 187 lb.)	57 N/mm (325 lb/in)
Weight of rider: 85... 95 kg (187... 209 lb.)	60 N/mm (343 lb/in)
Spring length	260 mm (10.24 in)
Gas pressure	10 bar (145 psi)
Static sag	30 mm (1.18 in)
Riding sag	100 mm (3.94 in)
Fitted length	490 mm (19.29 in)
Shock absorber oil	Shock absorber fluid (SAE 2.5) (50180751S1) (☛ p. 258)

23.10 Chassis tightening torques

Screw, air filter box lid	EJOT PT® K60x20-Z	3 Nm (2.2 lbf ft)	–
Screw, pressure regulator	EJOT PT® K60x25-Z	3 Nm (2.2 lbf ft)	–
Spoke nipple, front wheel	M4.5	6 Nm (4.4 lbf ft)	–
Spoke nipple, rear wheel	M4.5	6 Nm (4.4 lbf ft)	–
Screw, battery terminal	M5	2.5 Nm (1.84 lbf ft)	–
Screw, intake air temperature sensor	M5	2 Nm (1.5 lbf ft)	–
Screw, shock absorber adjusting ring	M5	5 Nm (3.7 lbf ft)	–
Nut, cable on starter motor	M6	4 Nm (3 lbf ft)	–
Remaining nuts, chassis	M6	10 Nm (7.4 lbf ft)	–
Remaining screws, chassis	M6	10 Nm (7.4 lbf ft)	–
Screw, ball joint of push rod on foot brake cylinder	M6	10 Nm (7.4 lbf ft)	Loctite® 243™
Screw, chain sliding guard	M6	6 Nm (4.4 lbf ft)	Loctite® 243™
Screw, front brake disc	M6	14 Nm (10.3 lbf ft)	Loctite® 243™
Screw, rear brake disc	M6	14 Nm (10.3 lbf ft)	Loctite® 243™
Screw, throttle grip	M6	5 Nm (3.7 lbf ft)	–
Fuel connection on fuel tank	M8	10 Nm (7.4 lbf ft)	–
Nut, foot brake lever stop	M8	20 Nm (14.8 lbf ft)	–
Nut, rear sprocket screw	M8	35 Nm (25.8 lbf ft)	Loctite® 2701™
Nut, rim lock	M8	12 Nm (8.9 lbf ft)	–
Remaining nuts, chassis	M8	25 Nm (18.4 lbf ft)	–
Remaining screws, chassis	M8	25 Nm (18.4 lbf ft)	–
Screw, bottom triple clamp	M8	12 Nm (8.9 lbf ft)	–
Screw, chain sliding piece	M8	15 Nm (11.1 lbf ft)	–
Screw, engine brace	M8	33 Nm (24.3 lbf ft)	–
Screw, fork stub	M8	15 Nm (11.1 lbf ft)	–
Screw, front brake caliper	M8	25 Nm (18.4 lbf ft)	Loctite® 243™
Screw, handlebar clamp	M8	20 Nm (14.8 lbf ft)	–
Screw, side stand attachment (XC-F)	M8	45 Nm (33.2 lbf ft)	Loctite® 2701™
Screw, subframe	M8	35 Nm (25.8 lbf ft)	Loctite® 2701™
Screw, top steering stem	M8	17 Nm (12.5 lbf ft)	Loctite® 243™
Screw, top triple clamp	M8	17 Nm (12.5 lbf ft)	–
Engine carrying screw	M10	60 Nm (44.3 lbf ft)	–
Remaining nuts, chassis	M10	45 Nm (33.2 lbf ft)	–
Remaining screws, chassis	M10	45 Nm (33.2 lbf ft)	–
Screw, bottom shock absorber	M10	60 Nm (44.3 lbf ft)	Loctite® 2701™
Screw, handlebar support	M10	40 Nm (29.5 lbf ft)	Loctite® 243™
Screw, top shock absorber	M10	60 Nm (44.3 lbf ft)	Loctite® 2701™
Nut, fuel pump	M12	15 Nm (11.1 lbf ft)	–
Nut, seat fixing	M12x1	20 Nm (14.8 lbf ft)	–
Nut, frame to linkage lever	M14x1.5	80 Nm (59 lbf ft)	–
Nut, linkage lever on swingarm	M14x1.5	80 Nm (59 lbf ft)	–
Nut, linkage lever to angle lever	M14x1.5	80 Nm (59 lbf ft)	–
Nut, swingarm pivot	M16x1.5	100 Nm (73.8 lbf ft)	–
Screw, front wheel spindle	M20x1.5	35 Nm (25.8 lbf ft)	–
Screw, top steering head	M20x1.5	12 Nm (8.9 lbf ft)	–
Screw-in nozzles, cooling system	M20x1.5	12 Nm (8.9 lbf ft)	Loctite® 243™
Nut, rear wheel spindle	M25x1.5	80 Nm (59 lbf ft)	–

24.1 Cleaning the motorcycle

Note

Material damage Damage and destruction of components by high-pressure cleaning equipment.

- When cleaning the vehicle with a pressure cleaner, do not point the water jet directly onto electrical components, connectors, cables, bearings, etc. Maintain a minimum distance of 60 cm between the nozzle of the pressure cleaner and the component. Excessive pressure can cause malfunctions or destroy these parts.



Warning

Environmental hazard Hazardous substances cause environmental damage.

- Oil, grease, filters, fuel, cleaners, brake fluid, etc., should be disposed of as stipulated in applicable regulations.



Info

If you clean the motorcycle regularly, its value and appearance will be maintained over a long period. Avoid direct sunshine on the motorcycle during cleaning.

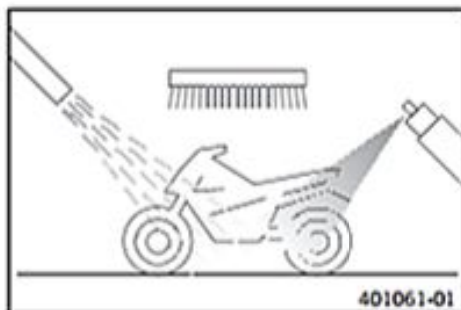

- Close off the exhaust system to prevent water from entering.
- First remove coarse dirt particles with a gentle spray of water.
- Spray very dirty areas with a normal motorcycle cleaner and then clean with a paintbrush.

Motorcycle cleaner (☛ p. 260)



Info

Use warm water containing normal motorcycle cleaner and a soft sponge. Never apply motorcycle cleaner to the dry vehicle; always rinse with water first.

- After rinsing the motorcycle with a gentle spray of water, allow it to dry thoroughly.
- Remove the plug from the exhaust system.



Warning

Danger of accidents Reduced braking efficiency due to a wet or dirty brake system.

- Clean or dry a dirty or wet brake system by riding and braking gently.

- After cleaning, ride a short distance until the engine reaches operating temperature.



Info

The heat produced causes water at inaccessible locations in the engine and the brake system to evaporate.

- Push back the protection caps of the handlebar controls to allow any water that has penetrated to evaporate.
- After the motorcycle has cooled off, lubricate all moving parts and bearings.
- Clean the chain. (☛ p. 126)
- Treat bare metal parts (except for brake discs and the exhaust system) with a corrosion inhibitor.

Preserving materials for paints, metal and rubber (☛ p. 261)

- Treat all plastic parts and powder-coated parts with a mild cleaning and care agent.

Special cleaner for glossy and matte paint finishes, metal and plastic surfaces (☛ p. 261)

25.1 Storage

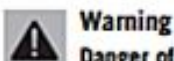
**Warning**

Danger of poisoning Fuel is poisonous and a health hazard.

- Fuel must not come into contact with the skin, eyes, or clothing. Do not breathe in the fuel vapors. If contact occurs with the eyes, rinse with water immediately and contact a physician. Immediately clean contaminated areas on the skin with soap and water. If fuel is swallowed, contact a physician immediately. Change clothing that is contaminated with fuel. Store fuel properly in a suitable canister and keep away from children.

**Info**

If you want to garage the motorcycle for a longer period, take the following steps.

Before storing the motorcycle, check all parts for function and wear. If service, repairs or replacements are necessary, you should do this during the storage period (less workshop overload). In this way, you can avoid long workshop waiting times at the start of the new season.

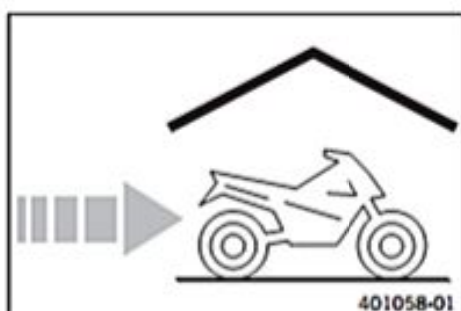

- When refueling for the last time before taking the motorcycle out of service, add fuel additive.

Fuel additive (☛ p. 260)

- Refuel.
- Clean the motorcycle. (☛ p. 242)
- Change the engine oil and oil filter and clean the oil screens. (☛ p. 226)
- Check the antifreeze and coolant level. (☛ p. 222)
- Check the tire air pressure. (☛ p. 118)
- Remove the battery. (☛ p. 129)
- Charge the battery. (☛ p. 129)

Guideline

Storage temperature of battery without direct sunlight	0... 35 °C (32... 95 °F)
--	--------------------------

- Store the vehicle in a dry location that is not subject to large fluctuations in temperature.

**Info**

KTM recommends raising the motorcycle.

- Raise the motorcycle with the lift stand. (☛ p. 10)
- Cover the vehicle with a tarp or a cover that is permeable to air.

**Info**

Do not use non-porous materials since they prevent humidity from escaping, thus causing corrosion.

Avoid running the engine for a short time only. Since the engine cannot warm up properly, the water vapor produced during combustion condenses and causes valves and exhaust system to rust.

25.2 Preparing for use after storage

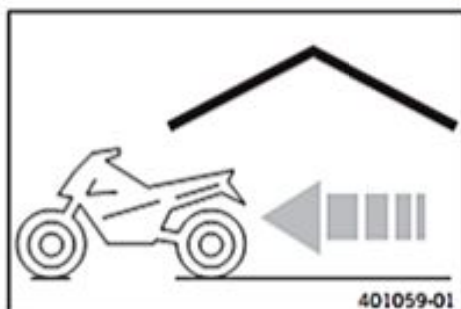

- Install the battery. (☛ p. 129)
- Remove the motorcycle from the lift stand. (☛ p. 10)
- Perform checks and maintenance work when preparing the vehicle for use.
- Make a test ride.

26.1 Service schedule

	Every 40 operating hours - corresponds to about 280 liters of fuel (74 US gal)	Every 30 operating hours - corresponds to about 210 liters of fuel (55.5 US gal)	Every 20 operating hours - corresponds to about 140 liters of fuel (37 US gal)	Once after 10 operating hours / Every 10 operating hours - corresponds to about 70 liters of fuel (18.5 US gal) / after every race	Once after 1 operating hour - corresponds to about 7 liters of fuel (1.8 US gal)
Read out the fault memory using the KTM diagnostics tool.	○	●	●	●	●
Check and charge the battery.		●	●	●	●
Check the front brake linings. (☛ p. 134)		●	●	●	●
Check the rear brake linings. (☛ p. 139)		●	●	●	●
Check the brake discs. (☛ p. 118)		●	●	●	●
Check the brake lines for damage and leakage.		●	●	●	●
Check the rear brake fluid level. (☛ p. 141)		●	●	●	●
Check the free travel of the foot brake lever. (☛ p. 141)		●	●	●	●
Check the frame and swingarm.		●	●	●	●
Check the swingarm bearing.			●		●
Check the shock absorber linkage. (☛ p. 82)		●	●	●	●
Conduct a minor fork service. (SX-F EU) (☛ p. 16)		●	●	●	●
Conduct a major fork service. (SX-F EU) (☛ p. 16)				●	
Perform a fork service. (SX-F USA, XC-F) (☛ p. 37)		○			●
Check the tire condition. (☛ p. 118)	○	●	●	●	●
Check the tire air pressure. (☛ p. 118)	○	●	●	●	●
Check the wheel bearing for play.		●	●	●	●
Check the wheel hubs.		●	●	●	●
Check the rim run-out.	○	●	●	●	●
Check the spoke tension. (☛ p. 119)	○	●	●	●	●
Check the chain, rear sprocket, engine sprocket, and chain guide. (☛ p. 124)		●	●	●	●
Check the chain tension. (☛ p. 123)	○	●	●	●	●
Grease all moving parts (e.g., hand lever, chain, ...) and check for smooth operation.		●	●	●	●
Check/correct the fluid level of the hydraulic clutch. (☛ p. 221)		●	●	●	●
Check the brake fluid level of the front brake. (☛ p. 136)		●	●	●	●
Check the free travel of the hand brake lever. (☛ p. 135)		●	●	●	●
Check the steering head bearing play. (☛ p. 71)	○	●	●	●	●
Check the valve clearance.	○			●	
Check the clutch.			●		●
Change the engine oil and oil filter and clean the oil screens. (☛ p. 226)	○	●	●	●	●
Check all hoses (e. g. fuel, cooling, bleeding, drainage) and sleeves for tearing, leaks and incorrect routing.	○	●	●	●	●
Check the antifreeze and coolant level. (☛ p. 222)	○	●	●	●	●
Check the cables for damage and routing without sharp bends.		●	●	●	●
Check that the cables are undamaged, routed without sharp bends and set correctly.	○	●	●	●	●
Clean the air filter and air filter box. (☛ p. 104)		●	●	●	●
Change the glass fiber yarn filling of the main silencer. (☛ p. 101)			●		●
Check the screws and nuts for tightness.	○	●	●	●	●
Change the fuel screen. (☛ p. 114)	○	●	●	●	●
Check the fuel pressure. (☛ p. 109)		●	●	●	●
Check idle.	○	●	●	●	●
Final check: Check the vehicle for safe operation and take a test ride.	○	●	●	●	●
Read out the fault memory using the KTM diagnostics tool after a test ride.	○	●	●	●	●
Make the service entry in KTM DEALER.NET and in the service record.	○	●	●	●	●

- One-time interval
- Periodic interval

26.2 Service work (as additional order)

				Annually
	Every 100 operating hours - corresponds to about 700 liters of fuel (185 US gal)			
	Every 50 operating hours - corresponds to about 350 liters of fuel (92.5 US gal)			
	Every 40 operating hours - corresponds to about 280 liters of fuel (74 US gal)			
	Once after 20 operating hours			
Change the front brake fluid. (☛ p. 138)				●
Change the rear brake fluid. (☛ p. 143)				●
Change the hydraulic clutch fluid. (☛ p. 221)				●
Grease the steering head bearing. (☛ p. 68)				●
Service the shock absorber. (☛ p. 84)	○	●		
Change the spark plug and spark plug connector.				●
Change the piston.			●	●
Check/measure the cylinder.			●	●
Check the cylinder head.			●	●
Change the valves, valve springs and valve spring seats.				●
Check the camshaft and rocker arm.			●	●
Change the connecting rod, conrod bearing, and crank pin.				●
Change the shaft seal rings of the water pump.			●	●
Check the transmission and shift mechanism.				●
Check the oil pressure regulator valve.				●
Change the suction pump.				●
Check the pressure pump and lubrication system.				●
Replace the timing chain.				●
Check the timing assembly.			●	●
Change all engine bearings.				●

- One-time interval
- Periodic interval

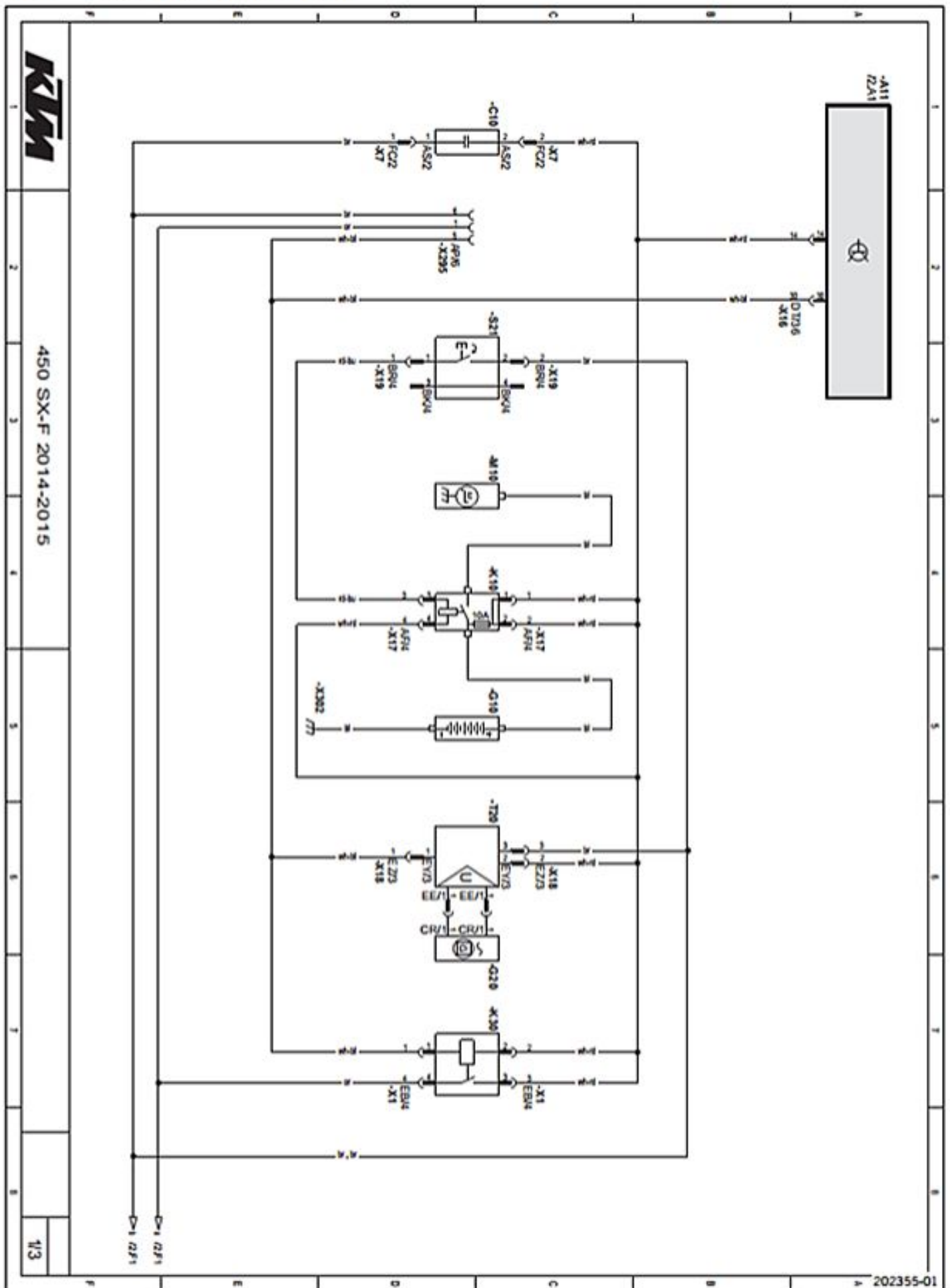

Components:

A11	EFI control unit
C10	Capacitor
G10	Battery
G20	Alternator
K10	Starter relay with main fuse
K30	Power relay
M10	Starter motor
T20	Voltage regulator
S21	Electric starter button
X295	Diagnostics connector

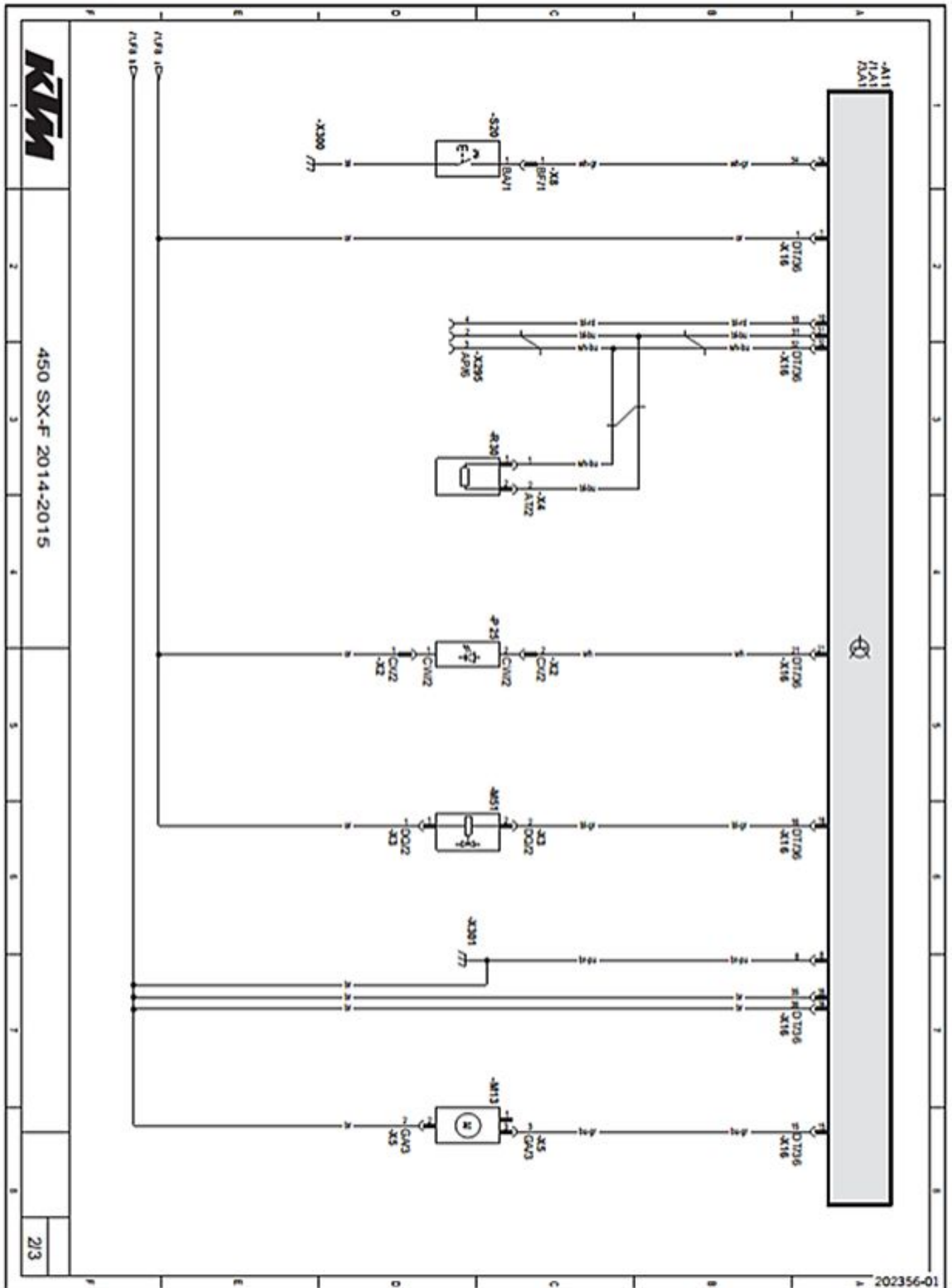

Components:

A11	EFI control unit
M13	Fuel pump
M51	Injector (cylinder 1)
P25	FI warning lamp (MIL)
R30	CAN-Bus terminating resistor
S20	Kill switch
X295	Diagnostics connector

Components:

A11	EFI control unit
B10	Throttle position sensor circuit A
B12	Intake air temperature sensor
B21	Engine coolant temperature sensor (cylinder 1)
B26	Rollover sensor
B37	Crankshaft position sensor
B41	Manifold absolute pressure sensor (cylinder 1)
R51	Ignition coil (cylinder 1)
S51	Map-Select switch for riding operation (optional)
S55	Map-Select switch (optional)

Cable colors:

bl	Black
br	Brown
bu	Blue
gn	Green
gr	Gray
lbu	Light blue
or	Orange
pk	Pink
pu	Violet
rd	Red
wh	White
ye	Yellow

Components:

A11	EFI control unit
C10	Capacitor
G10	Battery
G20	Alternator
K10	Starter relay with main fuse
K30	Power relay
M10	Starter motor
T20	Voltage regulator
S21	Electric starter button
X295	Diagnostics connector

27.5 Page 2 of 3 (XC-F)

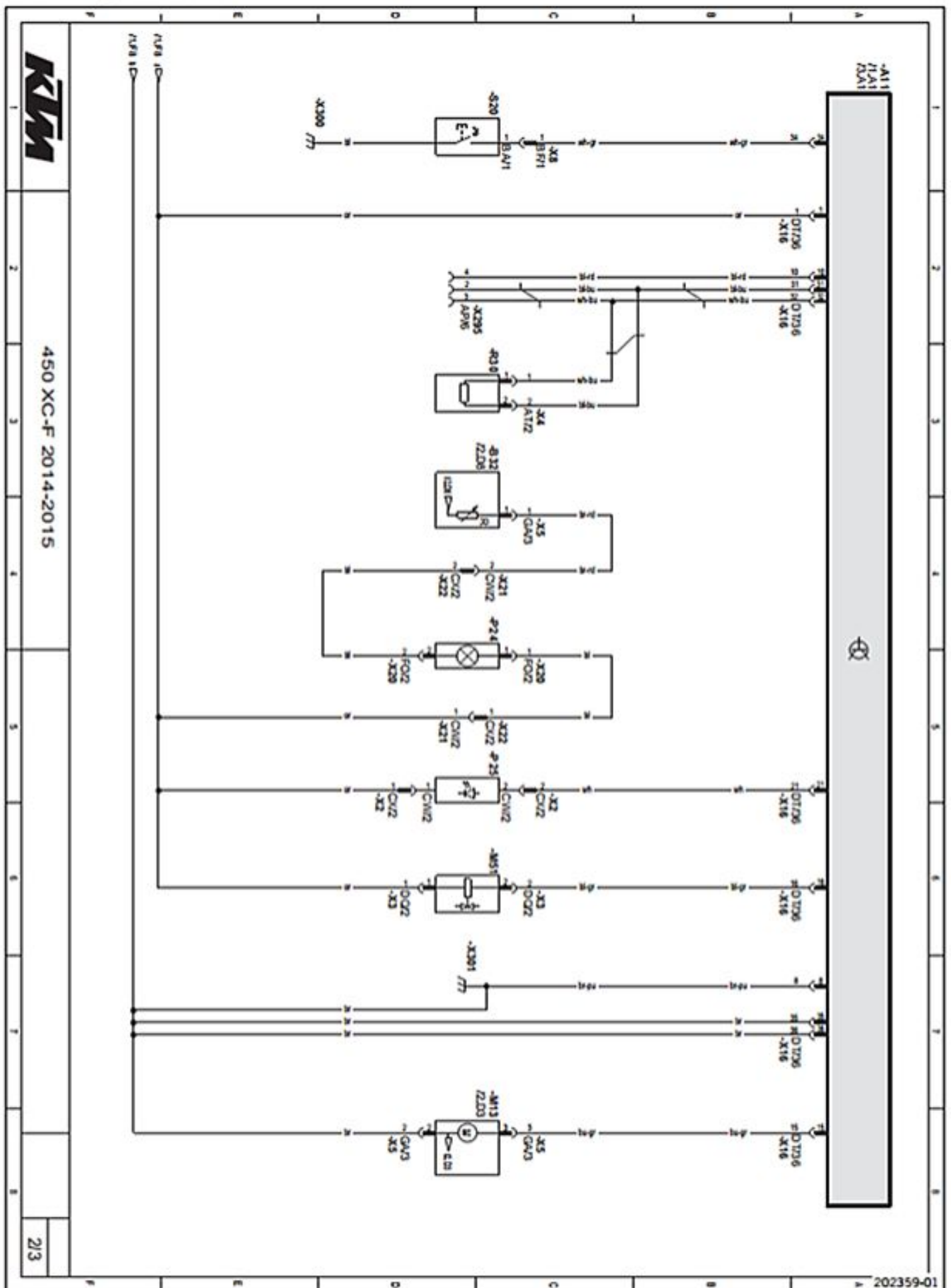

450 XC-F 2014-2015

Components:

A11	EFI control unit
B32	Fuel level indicator
M13	Fuel pump
M51	Injector (cylinder 1)
P24	Low fuel warning lamp
P25	FI warning lamp (MIL)
R30	CAN-bus terminating resistor
S20	Kill switch
X295	Diagnostics connector

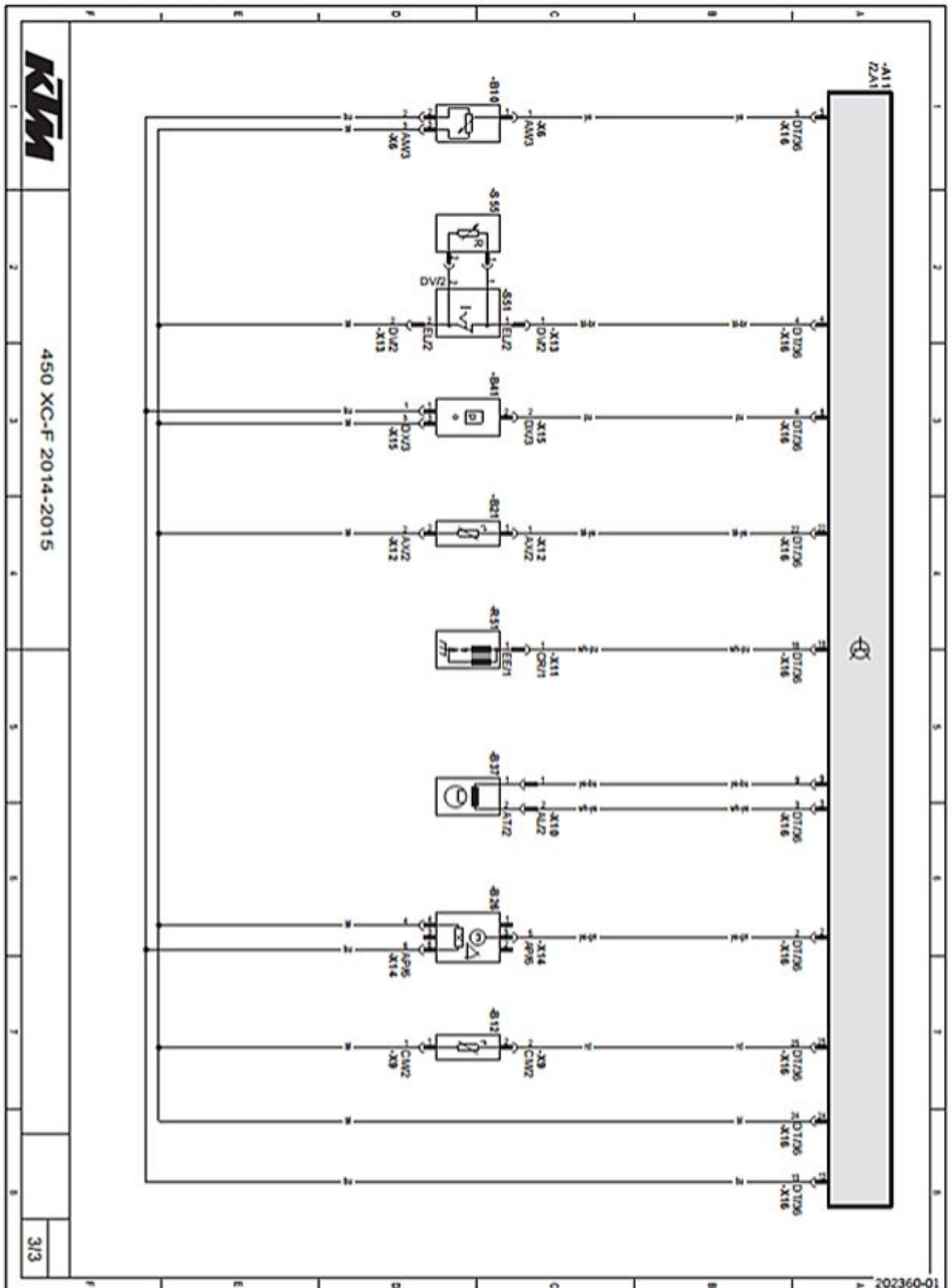

Components:

A11	EFI control unit
B10	Throttle position sensor circuit A
B12	Intake air temperature sensor
B21	Engine coolant temperature sensor (cylinder 1)
B26	Rollover sensor
B37	Crankshaft position sensor
B41	Manifold absolute pressure sensor (cylinder 1)
R51	Ignition coil (cylinder 1)
S51	Map switch for riding operation (optional)
S55	Map-Select switch (optional)

Cable colors:

bl	Black
br	Brown
bu	Blue
gn	Green
gr	Gray
lbu	Light blue
or	Orange
pk	Pink
pu	Violet
rd	Red
wh	White
ye	Yellow

Brake fluid DOT 4 / DOT 5.1

Standard/classification

- DOT

Guideline

- Use only brake fluid that complies with the specified standard (see specifications on the container) and that possesses the corresponding properties.

Recommended supplier

Castrol

- RESPONSE BRAKE FLUID SUPER DOT 4

Motorex®

- Brake Fluid DOT 5.1

Coolant

Guideline

- Use only suitable coolant (even in countries with high temperatures). Using inferior antifreeze can result in corrosion and foaming.

Mixture ratio

Antifreeze protection: -25... -45 °C (-13... -49 °F)	50 % anti-corrosion/antifreeze 50 % distilled water
--	--

Coolant (mixed ready to use)

Antifreeze protection	-38 °C (-36 °F)
-----------------------	-----------------

Recommended supplier

Motorex®

- COOLANT M3.0

Engine oil (SAE 10W/50)

Standard/classification

- JASO T903 MA (☛ p. 277)
- SAE (☛ p. 277) (SAE 10W/50)

Guideline

- Use only engine oils that comply with the specified standards (see specifications on the container) and that possess the corresponding properties.

Synthetic engine oil

Recommended supplier

Motorex®

- Cross Power 4T

Fork oil (SAE 4) (48601166S1)

Standard/classification

- SAE (☛ p. 277) (SAE 4)

Guideline

- Use only oils that comply with the specified standards (see specifications on the container) and that possess the corresponding properties.

Shock absorber fluid (SAE 2.5) (50180751S1)

Standard/classification

- SAE (☛ p. 277) (SAE 2.5)

Guideline

- Use only oils that comply with the specified standards (see specifications on the container) and that possess the corresponding properties.

Super unleaded (ROZ 95/RON 95/PON 91)

Standard/classification

- DIN EN 228 (ROZ 95/RON 95/PON 91)

Guideline

- Only use unleaded super fuel that matches or is equivalent to the specified fuel grade.
- Fuel with an ethanol content of up to 10 % (E10 fuel) is safe to use.



Info

Do **not** use fuel containing methanol (e. g. M15, M85, M100) or more than 10 % ethanol (e. g. E15, E25, E85, E100).

Air filter cleaner

Recommended supplier

Motorex®

- Racing Bio Dirt Remover

Chain cleaner

Recommended supplier

Motorex®

- Chain Clean

Fuel additive

Recommended supplier

Motorex®

- Fuel Stabilizer

High viscosity grease

Recommended supplier

SKF®

- LGHB 2

Long-life grease

Recommended supplier

Motorex®

- Bike Grease 2000

Lubricant (T158)

Recommended supplier

Lubcon®

- Turmogrease® PP 300

Lubricant (T511)

Recommended supplier

Lubcon®

- Turmsilon® GTI 300 P

Lubricant (T625)

Recommended supplier

Molykote®

- 33 Medium

Lubricant (T152)

Recommended supplier

Bel-Ray®

- Molylube® Anti-Seize

Lubricant (T159)

Recommended supplier

Bel-Ray®

- MC-11®

Motorcycle cleaner

Recommended supplier

Motorex®

- Moto Clean

Off-road chain spray

Recommended supplier

Motorex®

- Chainlube Offroad

Oil for foam air filter

Recommended supplier

Motorex®

- Racing Bio Liquid Power

Preserving materials for paints, metal and rubber

Recommended supplier

Motorex®

- Moto Protect

Special cleaner for glossy and matte paint finishes, metal and plastic surfaces

Recommended supplier

Motorex®

- Quick Cleaner

Universal oil spray

Recommended supplier

Motorex®

- Joker 440 Synthetic

Bleeder cover



Art. no.: 00029013005

Bleeder cover



Art. no.: 00029013006

Bleeding device



Art. no.: 00029013100

Locking screw

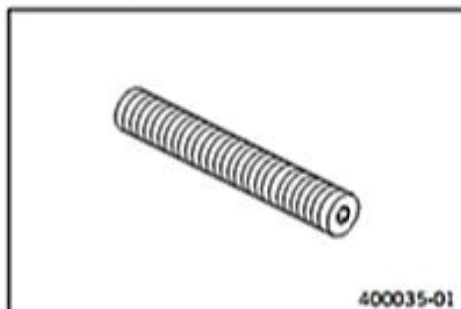

Art. no.: 113080802

Bearing puller

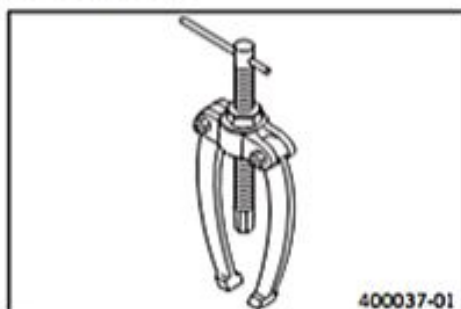

Art. no.: 15112017000

Insert for bearing puller

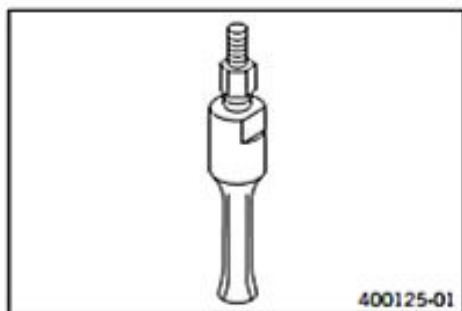

Art. no.: 15112018100

Feature

18... 23 mm (0.71... 0.91 in)

Tachometer

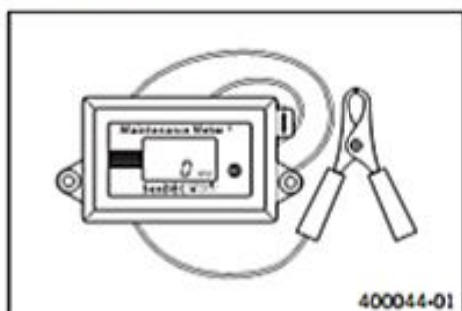

Art. no.: 45129075000

Spring hooks

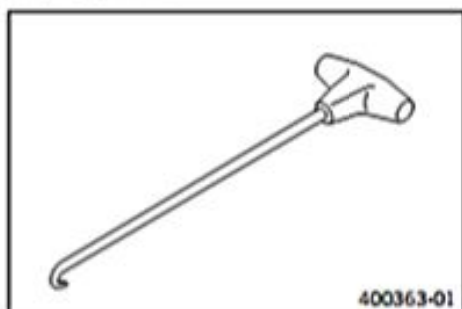

Art. no.: 50305017000

Bleed syringe



Art. no.: 50329050000

Circlip pliers reverse



Art. no.: 51012011000

Clutch holder

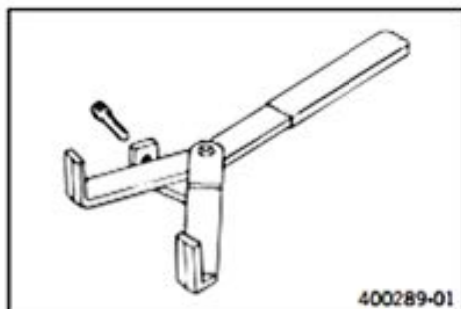

Art. no.: 51129003000

Lift stand



Art. no.: 54829055000

Extractor



Art. no.: 58012009000

Torque wrench with various accessories in set



Art. no.: 58429094000

Valve spring compressor



Art. no.: 59029019000

Limit plug gauge

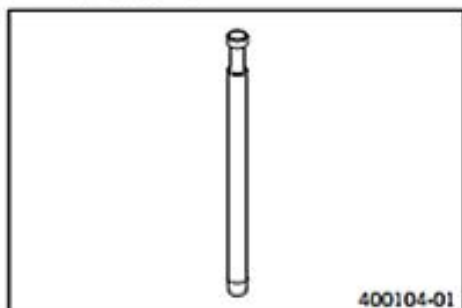

Art. no.: 59029026006

Feeler gauge

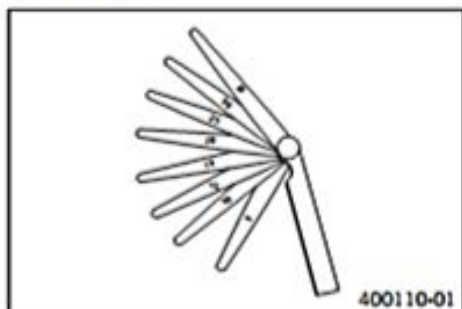

Art. no.: 59029041100

Piston ring mounting tool

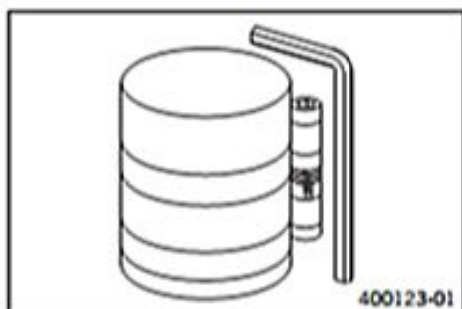

Art. no.: 60029015000

Puller, 2-arm

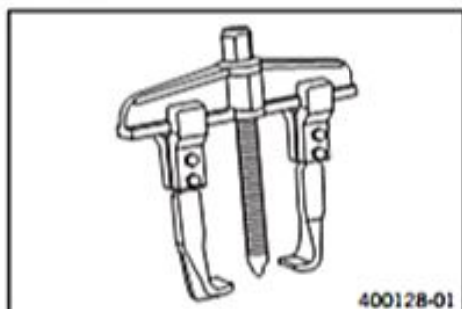

Art. no.: 60029033000

Hose clamp pliers

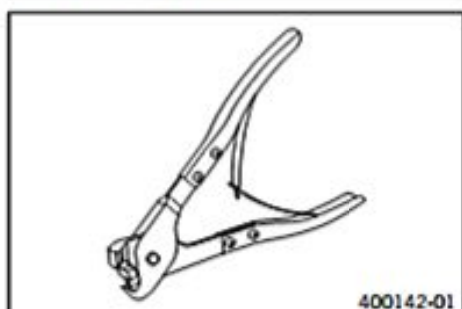

Art. no.: 60029057000

Testing hose

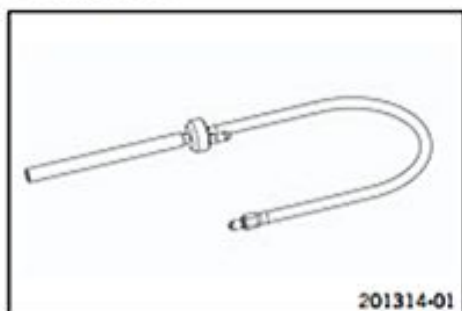

Art. no.: 61029093000

Pressure testing tool

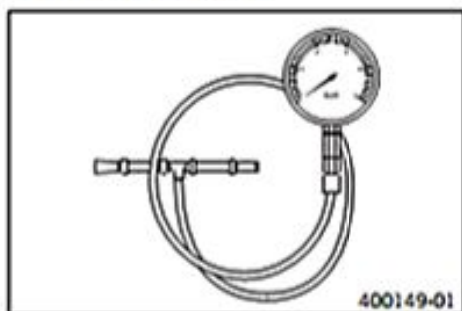

Art. no.: 61029094000

Engine assembly stand



Art. no.: 61229001000

Extractor

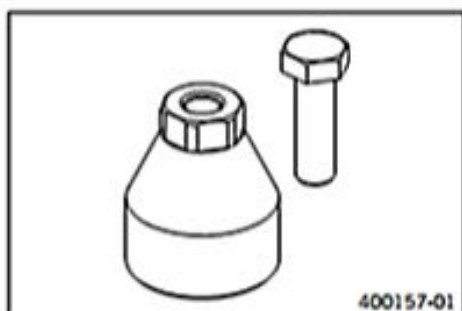

Art. no.: 75029021000

Push-in drift

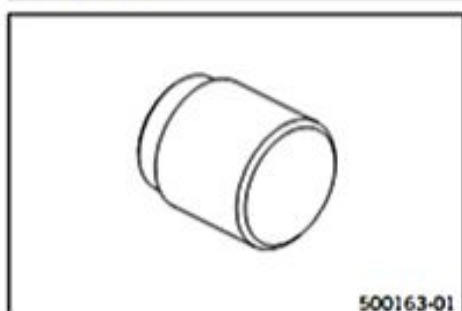

Art. no.: 75029044010

Push-in drift

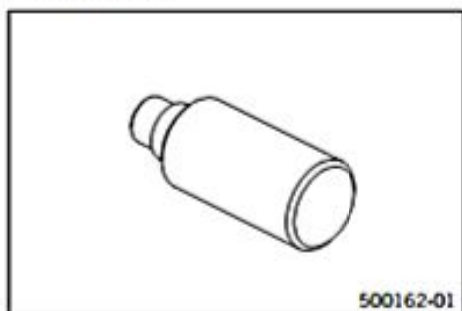

Art. no.: 75029044020

Pressing device for crankshaft, complete

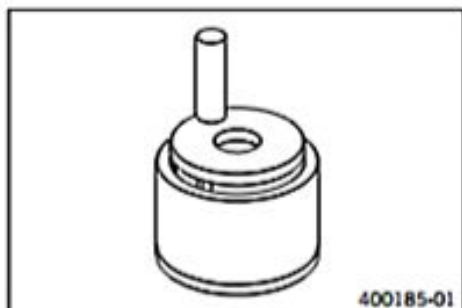

Art. no.: 75029047000

Clamping plate

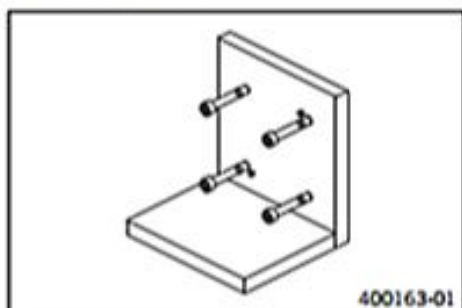

Art. no.: 75029050000

Push-out drift

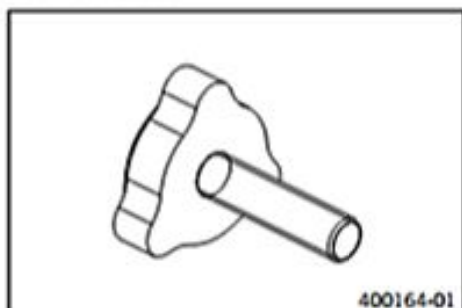

Art. no.: 75029051000

Protection cover

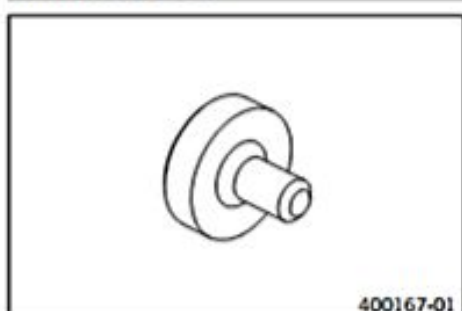

Art. no.: 75029090000

Oil pressure adapter

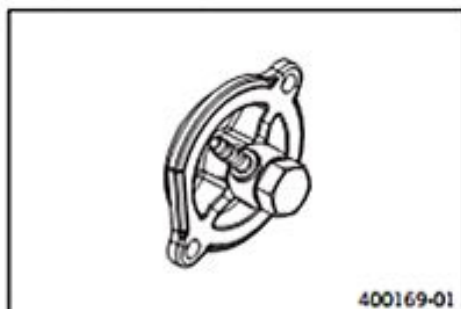

400169-01

Art. no.: 75029094000

Spark plug wrench

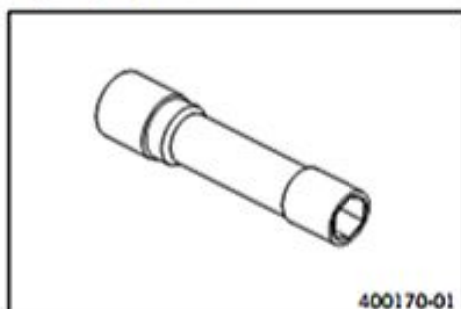

400170-01

Art. no.: 75029172000

Insert for valve spring lever



303272-10

Art. no.: 77029041000

Insert for piston pin retainer

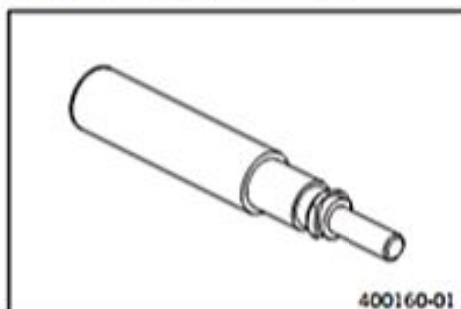

400160-01

Art. no.: 77329030100

Engine bracket

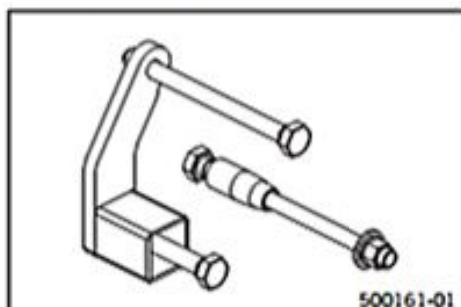

500161-01

Art. no.: 78029002000

Mounting sleeve

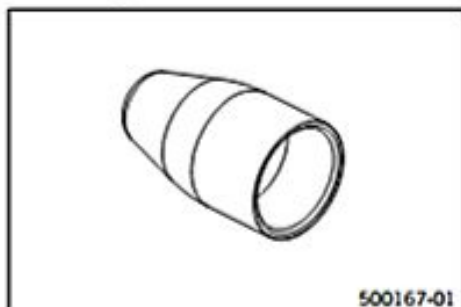

Art. no.: 78029005000

Removal tool

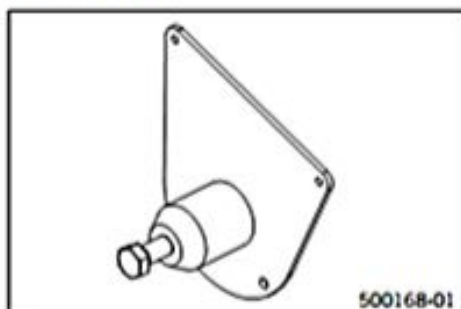

Art. no.: 78029049100

Fixing drift



Art. no.: 78129032000

Insert for crankshaft pressing tool



Art. no.: 78929008000

Separator plate



Art. no.: 78929009000

Gear quadrant

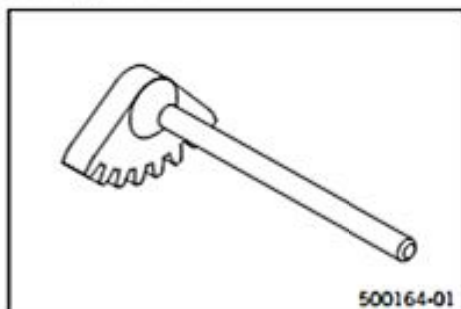

Art. no.: 80029004000

Mounting sleeve

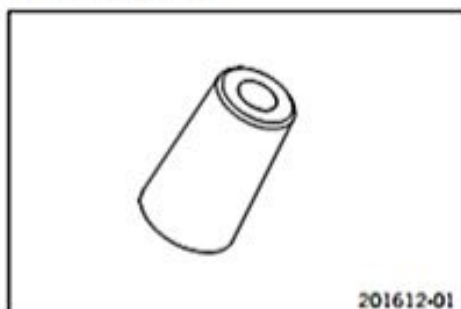

Art. no.: 90129005000

Case separating tool

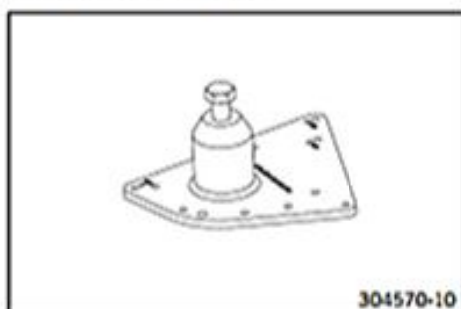

Art. no.: 90129048000

Pin wrench



Art. no.: T103

Hook wrench



Art. no.: T106S

Depth micrometer



Art. no.: T107S

Pin



Art. no.: T120

Mounting sleeve



Art. no.: T1204

Calibration pin



Art. no.: T1205

Pressing tool



Art. no.: T1206

Pressing tool



Art. no.: T1207S

Mounting sleeve



Art. no.: T1215

Disassembly tool



Art. no.: T1216

Vacuum pump



Art. no.: T1240S

Protecting sleeve



Art. no.: T1401

Clamping stand

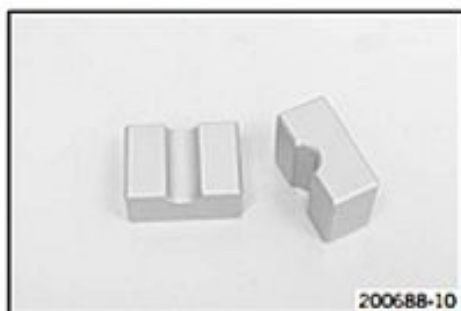

Art. no.: T14016S

Ring wrench



Art. no.: T14017

Nitrogen charging tool



Art. no.: T14019

Support tool

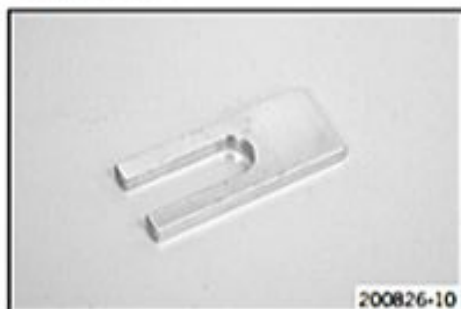

Art. no.: T14020

Calibrating unit



Art. no.: T14021

Mounting tool



Art. no.: T14022

Threaded bushing



Art. no.: T14023

Mounting sleeve



Art. no.: T14029

Filling adapter



Art. no.: T14030

Tweezers

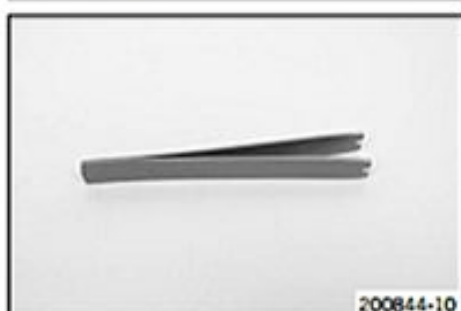

Art. no.: T14033

Clamping stand



Art. no.: T1403S

Mounting tool



Art. no.: T14040S

Special socket

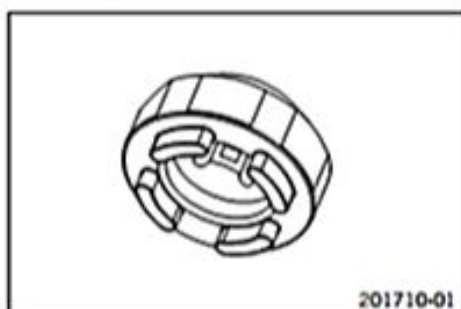

Art. no.: T14047

Clamping stand

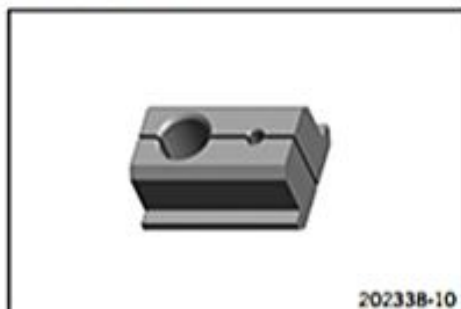

Art. no.: T14049S

Press-out tool



Art. no.: T14051

Press drift



Art. no.: T1504

Assembly tool



Art. no.: T150S

Nitrogen filling tool



Art. no.: T170S1

JASO T903 MA

Different technical development directions required a new specification for 4-stroke motorcycles – the JASO T903 MA Standard. Earlier, engine oils from the automobile industry were used for 4-stroke motorcycles because there was no separate motorcycle specification. Whereas long service intervals are demanded for automobile engines, high performance at high engine speeds are in the foreground for motorcycle engines. In most motorcycles, the gearbox and the clutch are lubricated with the same oil as the engine. The JASO MA Standard meets these special requirements.

SAE

The SAE viscosity classes were defined by the Society of Automotive Engineers and are used for classifying oils according to their viscosity. The viscosity describes only one property of oil and says nothing about quality.

A	
Accessories	8
Air filter	
cleaning	104
installing	104
removing	103
Air filter box	
cleaning	104
sealing	105
Air filter box lid	
installing	103
removing	103
securing	105
Alternator	
stator winding, checking	230
Antifreeze	
checking	222
Assembling the engine	
crankshaft, installing	202
valve clearance, checking	217
Auxiliary substances	8
B	
Battery	
charging	129
installing	129
removing	129
Brake disc	
front brake, installing	121
front brake, removing	121
rear brake, installing	123
rear brake, removing	123
Brake discs	
checking	118
Brake fluid	
front brake, adding	137
front brake, changing	138
rear brake, adding	142
rear brake, changing	143
Brake fluid level	
front brake, checking	136
rear brake, checking	141
Brake linings	
front brake, changing	134
front brake, checking	134
rear brake, changing	139
rear brake, checking	139
C	
Capacitor	
checking	131
Capacity	
coolant	224, 236
engine oil	154, 227, 236
fuel	236
Cartridge	
fork legs, assembling	30, 48, 63
fork legs, disassembling	19, 41-42, 57
Chain	
checking	124
cleaning	126
Chain guide	
checking	124
Chain tension	
adjusting	124
checking	123
Charging voltage	
checking	130
Chassis number	9
Clutch	
checking/correcting the fluid level	221
fluid, changing	221
Clutch lever	
basic position, adjusting	73
Compression damping	
fork, adjusting	12
Compression damping, high-speed	
shock absorber, adjusting	76
Compression damping, low-speed	
shock absorber, adjusting	76
Conducting major fork service	16
Conducting minor fork service	16
Coolant	
draining	223
refilling	224
Coolant level	
checking	222
Cooling system	222
Cylinder - Nikasil® coating	177
E	
Engine	
installing	149
removing	145
Engine - work on individual parts	
autodecompressor, assembling	180
autodecompressor, disassembling	179
camshaft bearing, changing	183
camshaft, checking	181
clutch, checking	187
connecting rod, conrod bearing, and crank pin, changing	175
countershaft, assembling	197
countershaft, disassembling	192
crankshaft run-out at the bearing pin, checking	177
crankshaft seal ring in clutch cover, changing	173
cylinder - Nikasil® coating	177
cylinder head, checking	184
cylinder, checking/measuring	177
freewheel, checking	200
freewheel, installing	201
freewheel, removing	201
left engine case section	171
main shaft, assembling	196
main shaft, disassembling	191
oil pressure regulator valve, installing	173

- oil pressure regulator valve, removing 172
 - oil pumps, checking 179
 - piston ring end gap, checking 178
 - piston, checking/measuring 178
 - piston/cylinder, determining the mounting clearance . . 179
 - right engine case section 170
 - rocker arm shafts, checking 185
 - rocker arm, installing 186
 - rocker arm, removing 182
 - shift mechanism, checking 188
 - shift shaft, preassembling 190
 - spring length of oil pressure regulator valve, checking . 172
 - starter drive, checking 200
 - timing assembly, checking 181
 - timing chain sprocket, installing 175
 - timing chain sprocket, removing 175
 - transmission, checking 193
 - valve spring seat, checking 184
 - valve springs, checking 184
 - valves, checking 183
 - valves, installing 185
 - valves, removing 182
 - water pump, installing 174
 - water pump, removing 173
- Engine assembly**
- alternator cover, installing 217
 - camshaft, installing 216
 - clutch cover, installing 210
 - clutch discs, installing 209
 - clutch push rod, installing 219
 - cylinder head, installing 215
 - engine, removing from engine assembly stand 220
 - force pump, installing 206
 - freewheel gear, installing 206
 - ignition pulse generator, installing 212
 - left engine case, installing 204
 - locking lever, installing 207
 - oil filter, installing 218
 - oil screens, installing 219
 - outer clutch hub, installing 208
 - piston, installing 213
 - primary gear, installing 206
 - rotor, installing 213
 - shift drum locating unit, installing 207
 - shift drum, installing 203
 - shift forks, installing 203
 - shift rails, installing 204
 - shift shaft, installing 207
 - spark plug, installing 218
 - starter idler gear, installing 208
 - starter motor, installing 218
 - suction pump, installing 211
 - timing chain tensioner, installing 216
 - timing chain, installing 212
 - torque limiter, installing 208
 - transmission shafts, installing 202
 - valve clearance, adjusting 217
 - valve cover, installing 218
 - water pump cover, installing 211
- Engine disassembly**
- alternator cover, removing 157
 - camshaft, removing 158
 - clutch cover, removing 161
 - clutch discs, removing 162
 - clutch push rod, removing 156
 - crankshaft, removing 169
 - cylinder head, removing 159
 - engine oil, draining 155
 - engine, positioning at ignition top dead center 157
 - force pump, removing 165
 - freewheel gear, removing 166
 - ignition pulse generator, removing 160
 - left section of the engine case, removing 166
 - locking lever, removing 164
 - oil filter, removing 156
 - outer clutch hub, removing 163
 - piston, removing 159
 - preparations 155
 - primary gear, removing 166
 - rotor, removing 159
 - shift drum locating unit, removing 164
 - shift drum, removing 167
 - shift forks, removing 168
 - shift rails, removing 167
 - shift shaft, removing 164
 - spark plug, removing 156
 - starter idler gear, removing 164
 - starter motor, removing 156
 - suction pump, removing 161
 - timing chain tensioner, removing 158
 - timing chain, removing 160
 - torque limiter, removing 164
 - transmission shafts, removing 168
 - valve cover, removing 157
 - water pump cover, removing 161
- Engine number** 9
- Engine oil**
- adding 228
 - changing 226
- Engine oil level**
- checking 225
- Engine oil pressure**
- checking 228
- Engine sprocket**
- checking 124
- F**
- Figures** 8
- Filler cap**
- closing 106
 - opening 106
- Foot brake lever**
- basic position, adjusting 141
 - free travel, checking 141
- Fork legs**
- assembling 32, 49, 64
 - bleeding 13
 - cartridge, assembling 30, 48, 63
 - cartridge, bleeding and filling 35
 - cartridge, disassembling 19, 41-42, 57
 - cartridge, filling with nitrogen 37

- checking 24, 45, 60
- compression damping, adjusting 12
- disassembling 17, 38, 54
- dust boots, cleaning 14
- fork service, performing 37, 53
- hydrostop unit, assembling 46, 61
- hydrostop unit, disassembling 44, 59
- installing 15
- major fork service, conducting 16
- minor fork service, checking 26
- minor fork service, conducting 16
- pilot bushing, changing 27
- piston rod, assembling 29, 47, 62
- piston rod, disassembling 21, 43, 58
- rebound damping, adjusting 12
- removing 14
- screw cap with membrane holder, assembling 28
- screw cap with membrane holder, disassembling 23
- screw sleeve, assembling 28
- screw sleeve, disassembling 24
- seal ring retainer, assembling 46, 61
- seal ring retainer, disassembling 45, 59
- spring, removing 40, 56
- Fork protector**
 - installing 16
- Fork service, performing** 37, 53
- Front fender**
 - installing 116
 - removing 116
- Front wheel**
 - installing 120
 - removing 119
- Fuel filter**
 - changing 112
- Fuel pressure**
 - checking 109
- Fuel pump**
 - changing 110
- Fuel screen**
 - changing 114
- Fuel tank**
 - installing 108
 - removing 107
- Fuse**
 - main fuse, changing 128
- H**
- Hand brake lever**
 - basic position, adjusting 136
 - free travel, checking 135
- Handlebar position**
 - adjusting 73
- Hydrostop unit**
 - fork legs, assembling 46, 61
 - fork legs, disassembling 44, 59
- I**
- Idle speed**
 - adjusting 233
- Ignition coil**
 - secondary winding, checking 230
- Initialization run**
 - executing 233
- L**
- Lower triple clamp**
 - installing 69
 - removing 68
- M**
- Main fuse**
 - changing 128
- Main silencer**
 - glass fiber yarn filling, changing 101
 - installing 101
 - removing 101
- Manifold**
 - installing 100
 - removing 100
- Motorcycle**
 - cleaning 242
 - raising with lift stand 10
 - removing from lift stand 10
- O**
- Oil circuit** 225
- Oil filter**
 - changing 226
- Oil pressure regulator valve**
 - installing 173
 - removing 172
 - spring length, checking 172
- Oil screens**
 - cleaning 226
- Operating substances** 8
- P**
- Piston rod**
 - fork legs, assembling 29, 47, 62
 - fork legs, disassembling 21, 43, 58
- Play in throttle cable**
 - adjusting 75
- Preparing for use**
 - after storage 243
- Q**
- Quiescent current**
 - checking 131
- R**
- Rear sprocket**
 - checking 124
- Rear wheel**
 - installing 122
 - removing 121
- Rebound damping**
 - fork, adjusting 12
 - shock absorber, adjusting 77

- Riding sag
 - adjusting 79
- S**
- Screw cap with membrane holder
 - fork legs, assembling 28
 - fork legs, disassembling 23
- Screw sleeve
 - fork legs, assembling 28
 - fork legs, disassembling 24
- Seal ring retainer
 - fork legs, assembling 46, 61
 - fork legs, disassembling 45, 59
- Seat
 - mounting 107
 - removing 107
- Service schedule 244-245
- Servicing the shock absorber 84
- Shock absorber
 - compression damping, high-speed, adjusting 76
 - compression damping, low-speed, adjusting 76
 - damper, assembling 93
 - damper, bleeding and filling 95
 - damper, checking 88
 - damper, disassembling 85
 - damper, filling with nitrogen 97
 - heim joint, installing 90
 - heim joint, removing 89
 - installing 81
 - pilot bushing, changing 88
 - piston rod, assembling 91
 - piston rod, disassembling 86
 - rebound damping, adjusting 77
 - removing 80
 - riding sag, checking 78
 - seal ring retainer, assembling 91
 - seal ring retainer, disassembling 87
 - shock absorber, servicing 84
 - spring preload, adjusting 79
 - spring, installing 98
 - spring, removing 84
 - static sag, checking 78
- Shock absorber linkage
 - checking 82
- Spare parts 8
- Spark plug connector
 - checking 230
- Spoke tension
 - checking 119
- Spring
 - fork legs, removing 40, 56
- Start number plate
 - installing 117
 - removing 116
- Starter motor
 - checking 232
- Starter relay
 - checking 132
- Starting 10
 - for checking 11
- Stator
 - installing 231
 - removing 231
- Steering head bearing
 - greasing 68
- Steering head bearing play
 - adjusting 71
 - checking 71
- Storage 243
- T**
- Technical data
 - capacities 236
 - chassis 236
 - chassis tightening torques 241
 - electrical system 237
 - engine 234
 - engine - tolerance, wear limits 234
 - engine tightening torques 235
 - fork 238
 - shock absorber 239
 - tires 237
- Throttle cable play
 - checking 74
- Throttle cable routing
 - checking 74
- Tire air pressure
 - checking 118
- Tire condition
 - checking 118
- Type label 9
- W**
- Warranty 8
- Wiring diagram 246-257
 - page 1 of 3 246, 252
 - page 2 of 3 248, 254
 - page 3 of 3 250, 256
- Work rules 7



3206208en

07/2014



KTM